

EUD-2016018-00

# SmartScanNG<sup>2</sup> Wayside Enclosure Components

“Wayside Enclosure Components” refer to those SmartScanNG<sup>22</sup> detector subsystems that are typically contained within the equipment bungalow. These components include:

- SmartScanNG<sup>22</sup> Controller
- Power Subsystem
- AEI Subsystem
- Temperature Probe

This manual provides an overview of these subsystems as well as detailed procedures for site preparation, installation, and placing a system into service.

18 Jan 2016

© 2016 Southern Technologies Corporation (STC). All rights reserved.  
Printed in the USA.

Because products evolve and system configurations change, this manual may not be an exact representation of the products and systems that you are using.

STC assumes no responsibility for errors or omissions in this document. Nor does STC make any commitment to update the information contained herein.

Product and company names mentioned herein are trademarks or registered trademarks of their respective owners.

# WARNING!

Contact with electrically active parts could result in sparks, burns, and electric shock. Because of this, you should avoid all electrical hazards when installing, wiring, operating, and maintaining the SmartScanNG<sup>2</sup> system. Failure to do so could result in damage to the equipment or serious injury to you.

## NOTICE:

If equipped with an AEI subsystem, the user is required to obtain a Part 90 site license from the FCC to operate in the United States. See product label for FCC ID number. Access the FCC Web site at [www.fcc.gov/Forms/Form601/601.html](http://www.fcc.gov/Forms/Form601/601.html) for additional information concerning licensing requirements.

Users in all countries should check with the appropriate local authorities for licensing requirements.

**Southern Technologies Corporation**  
**6145 Preservation Drive**  
**Chattanooga, TN 37416**  
**[www.southern-tech.com](http://www.southern-tech.com)**

email: [stcemail@southern-tech.com](mailto:stcemail@southern-tech.com)

fax number: 423-499-0045

telephone number: 423-892-3029

# Contents

---

This section lists the headings of this guide in sequential order with their page references.

<b>Contents .....</b>	<b>3</b>
<b>1.0 Introduction .....</b>	<b>5</b>
1.1 Purpose of This Guide .....	5
1.2 SmartScanNG <sup>2</sup> - Wayside Enclosure Components .....	5
1.3 Cautions .....	5
1.4 Disclaimers .....	6
1.5 How to Comment on This Guide .....	6
1.6 How to Order More Copies of This Guide .....	6
1.7 Standard Warranty .....	7
<b>2.0 SmartScanNG<sup>2</sup> Enclosure .....</b>	<b>9</b>
2.1 SmartScanNG <sup>2</sup> Enclosure .....	9
2.1.1 System-Interconnect Board (2300-106) .....	10
2.1.2 Controller Module (2300-602) .....	11
2.1.2.1 Display Panel .....	12
2.1.2.2 Processor Modules .....	17
2.1.2.3 Interface Board (2300-110) .....	18
2.1.2.4 Velocity Modem Board .....	20
2.1.2.5 Controller Module Connector Panel .....	21
2.1.3 SOTC Board (Zepic III) .....	22
2.1.4 Surge-Protection Panel .....	23
2.1.5 Relay Panel .....	24
2.1.6 Radio .....	24
2.1.7 Other Components .....	25
2.1.7.1 DC Power Switch .....	26
2.1.7.2 External Radio Connector .....	26
2.1.7.3 Chassis Mounted LEDs .....	27
<b>3.0 Power Subsystem .....</b>	<b>29</b>
3.1 Power Subsystem .....	29
3.2 Battery .....	29
3.3 Battery Charger .....	30
3.4 DC Power Distribution .....	31
<b>4.0 Shielded Temperature Probe .....</b>	<b>33</b>
<b>5.0 AEI Subsystem .....</b>	<b>35</b>
5.1 2300-750 AEI Interface Module .....	35
5.1.1 Components on Outside of Module .....	36
5.1.2 Components on Transcore AR2200 Board .....	37
5.2 2300-752 MPRR Panel .....	37
5.2.1 MPRR .....	39
5.2.2 DC-DC Converter .....	40
5.2.3 DB9 Breakout Board .....	40
<b>6.0 Preparation .....</b>	<b>41</b>
6.1 Selecting a Site .....	41

6.2	Preparing the Scanner Location .....	41
6.3	Preparing the AEI Antenna Masts .....	42
6.4	Preparing the Wayside Enclosure .....	43
6.5	Receiving Your System .....	45
6.6	Returning Damaged or Defective Hardware .....	45
6.7	Getting Help with the Installation .....	45
6.8	Identifying the Installation Tools .....	46
<b>7.0</b>	<b>Installing Wayside Enclosure Components .....</b>	<b>47</b>
7.1	Grounding System .....	47
7.2	SmartScanNG <sup>2</sup> Enclosure .....	47
7.3	Battery Charger .....	49
7.4	Fuse Block .....	51
7.5	Power Subsystem .....	52
7.6	Bearing Scanners .....	54
7.7	Wheel Scanners .....	55
7.8	Gating Transducers .....	55
7.9	Advance Transducers .....	57
7.10	Dragging-Equipment Detector .....	57
7.11	Telephone .....	58
7.12	Shielded Temperature Probe .....	59
7.13	Radio Antenna .....	61
7.14	AEI Interface Module .....	61
7.15	High-Load/High-Wide Detector .....	63
<b>8.0</b>	<b>Placing a System into Service .....</b>	<b>65</b>
8.1	Checking the Trackside Components .....	65
8.2	Checking the Wayside Enclosure Components .....	66
8.3	Powering-up the SmartScanNG <sup>2</sup> System .....	67
8.4	Checking the Scanner Shutters .....	72
8.5	Calibrating Scanners .....	74
8.5.1	Bearing Scanners .....	74
8.5.2	Wheel Scanners .....	79
8.6	Calibrating the Zepic III Presence Detector .....	81
8.7	Checking the Broadcast .....	82
8.8	Checking the Speech Data .....	84
8.9	Generating Test Trains .....	85
8.10	Setting Transducer Gain .....	87
8.11	Doing the Final Activities .....	89
<b>9.0</b>	<b>Customer Service .....</b>	<b>97</b>
9.1	Reaching STC .....	97
9.2	Returning Equipment for Repair .....	97
9.3	Reporting Problems or Suggestions .....	98
9.4	Ordering Spare Parts .....	98
9.5	Checking on Shipments and Orders .....	98
<b>Index</b>	<b>.....</b>	<b>99</b>

# 1.0 Introduction

---

This section summarizes the purpose of this guide, describes the SmartScanNG<sup>2</sup> system, tells how to comment on this guide, tells how to order more copies of this guide, and covers STC's standard warranty. It also covers the cautions and disclaimers of which the customer should be aware.

## 1.1 Purpose of This Guide

The technical staff at Southern Technologies Corporation (STC) created the SmartScanNG<sup>2</sup> defect detection system. It is designed to monitor moving trains and report certain conditions detected on these trains. The SmartScanNG<sup>2</sup> system is modular and firmware driven. Hardware and firmware can be changed to meet the unique needs of a given railroad. Thus, some of the components that make up a SmartScanNG<sup>2</sup> system differ from railroad to railroad.

This guide covers the portion of the SmartScanNG<sup>2</sup> system that is housed within the wayside enclosure. It describes the functionality, installation, and operation of these components.

## 1.2 SmartScanNG<sup>2</sup> - Wayside Enclosure Components

In this guide, the structure that houses the SmartScanNG<sup>2</sup> is called the "wayside enclosure." This structure, which comes in many shapes and sizes, can be any appropriate waterproof enclosure located adjacent to the tracks. It goes by many other names, such as bungalow, location case, apparatus housing, and equipment enclosure.

Attached to the inside of most wayside enclosures is:

- One SmartScanNG<sup>2</sup> enclosure per track
- One power subsystem per SmartScanNG<sup>2</sup> enclosure

Attached to the outside of most wayside enclosures is:

- One antenna per radio
- One shielded temperature probe per SmartScanNG<sup>2</sup> enclosure

## 1.3 Cautions

Contact with electrically active parts could result in sparks, burns, and electric shock. Because of this, you should avoid all electrical hazards when installing, wiring, operating, and maintaining the SmartScanNG<sup>2</sup> system. Failure to do so could result in damage to the equipment or serious injury to you.

In operation, batteries generate and release flammable hydrogen gas, which, if ignited by a burning cigarette, naked flame, or spark, may cause battery explosion with dispersion of casing fragments and corrosive liquid electrolyte. So, carefully follow manufacturer's instructions. Keep all sources of gas ignition away from the batteries and do not allow metallic articles to contact the negative and positive terminals of a battery at the same time.

Do not install any tower, pole, mast, or antenna on a wet or windy day. Do not install them near any type of power line. Be sure all parts of the system are out of falling range of any overhead wires, including the lead to any building. Once installed, do not climb any tower, pole, or mast. Failure to follow these instructions could result in injury or death.

## **1.4 Disclaimers**

The correct use of this guide, the environmental conditions at the time of installation, the method of installation itself, and the installation of customer-supplied components are beyond the control of STC. So too are the correct use and maintenance of all or part of the SmartScan system. Therefore, the installer, user, and maintainer must assume the risk of any injury that might occur during installation, use, and maintenance of all or part of the SmartScan system. STC assumes no risk, liability, or responsibility for errors and omissions on the part of the installer, user, or maintainer.

## **1.5 How to Comment on This Guide**

We want to hear from you. Tell us what you like or don't like about this guide. Send your comments to:

Southern Technologies Corporation  
Technical Publications Department  
6145 Preservation Drive  
Chattanooga, Tennessee 37416-3638  
USA

All comments become the sole property of STC and none will be returned.

## **1.6 How to Order More Copies of This Guide**

When placing an order for more copies of this guide, refer to the order number shown on the cover of this guide. To request pricing and delivery, call 423-892-3029, fax 423-499-0045, or send email to [stcemail@southern-tech.com](mailto:stcemail@southern-tech.com). Electronic copies of this guide are also available.

## 1.7 Standard Warranty

Systems manufactured by Southern Technologies Corporation carry a 14-month warranty from date of shipment. Warranty is limited to repair or replacement at the sole discretion of STC, of any goods found to be defective in either materials or workmanship during the 14-month period following shipment. Warranty does not apply to product with signs of obvious abuse, or product that has been improperly installed.

STC warrants that goods represented by this warranty statement have been designed and manufactured with all reasonable care and attention to appropriate regulatory documents. STC makes no representation that the goods covered by this warranty are suitable for the application they are used for. Application of the goods is at the sole discretion of the purchaser.

Purchaser is responsible for shipment of the defective product to STC. STC will pay the return shipping charges.

Products purchased from others, but included in STC systems carry the original manufacturer's warranty, typically 12 months. Warranty claims for these products must be made directly to the original equipment manufacturer.





## 2.0 SmartScanNG<sup>2</sup> Enclosure

### 2.1 SmartScanNG<sup>2</sup> Enclosure

There is one SmartScanNG<sup>2</sup> enclosure per track. At double-track sites, the one on the left supports track1 and the one on the right supports track2.

As a minimum, most SmartScanNG<sup>2</sup> enclosures contain:

- System-Interconnect board
- Controller module, containing Processor, Interface, and Modem boards
- Surge-protection panel
- Relay panel

Additionally, most SmartScanNG<sup>2</sup> enclosures usually contain:

- Radio (aka RF transceiver)
- Other components

This guide covers all the hardware components listed above, even though your site may not have all of them.

The next two figures show the major parts of the SmartScanNG<sup>2</sup> enclosure.

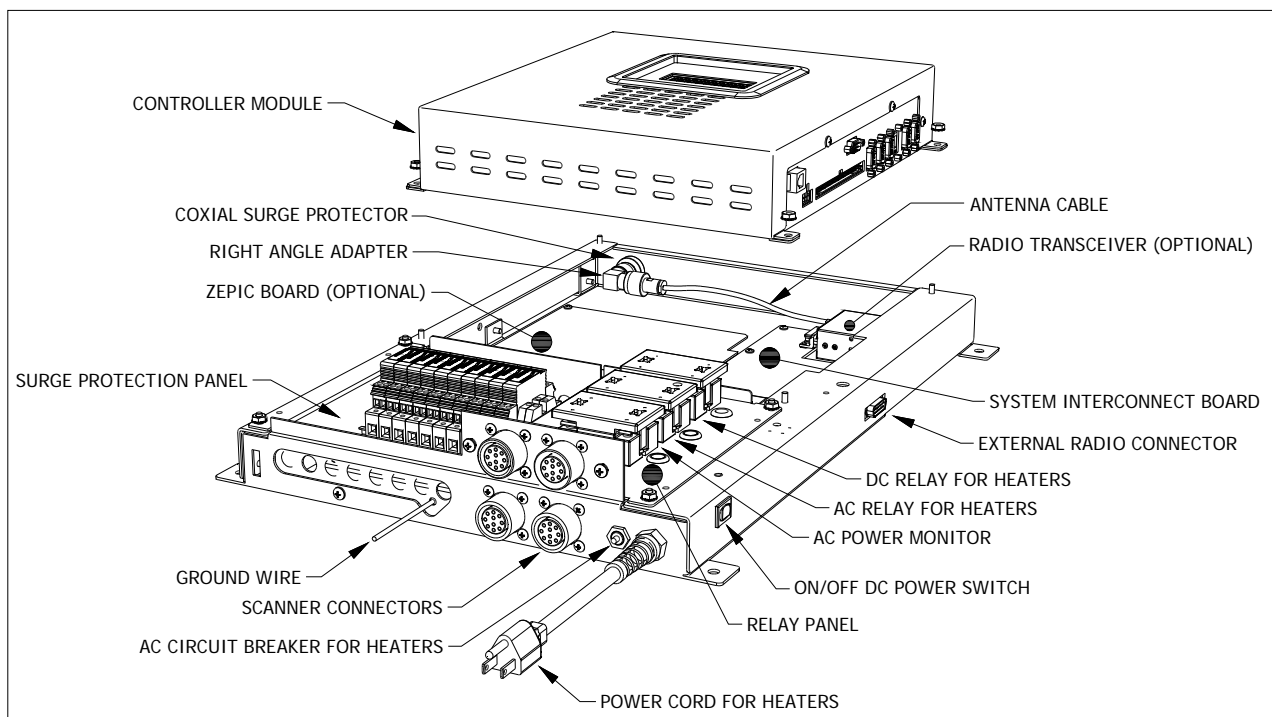

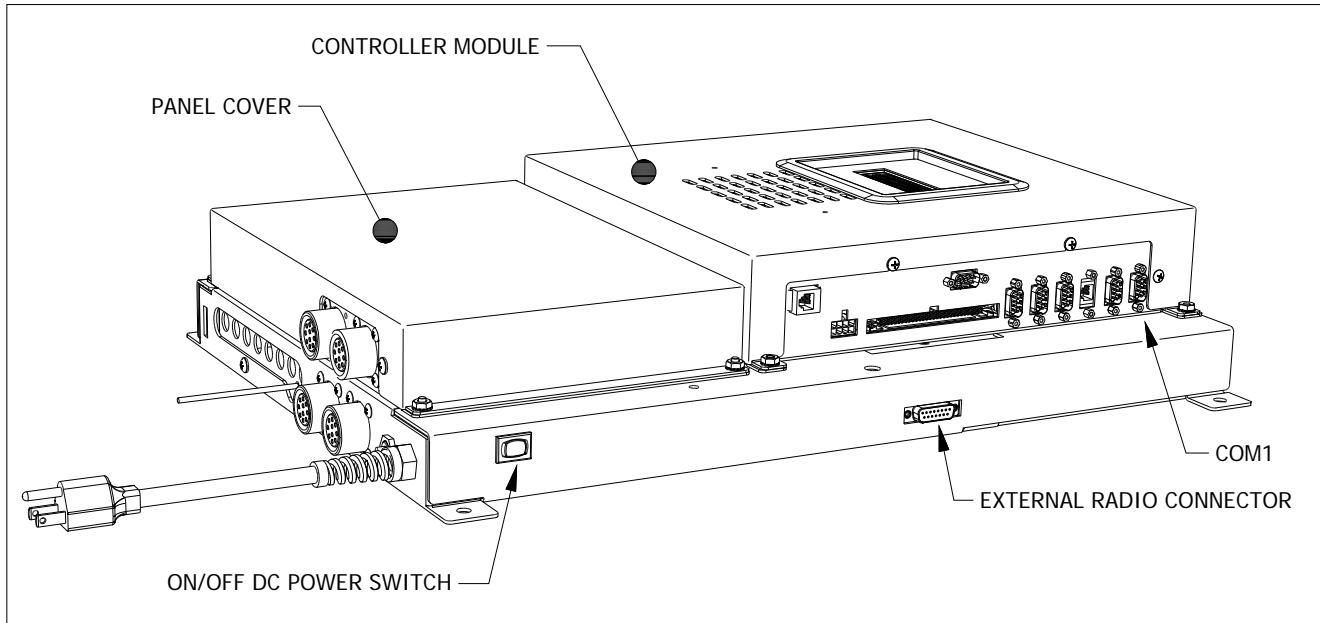

The power cord at the bottom of the SmartScanNG<sup>2</sup> enclosure is used to power the heaters in the 2500-512AC scanner. This cord should be plugged into a grounded three-wire 120-volt outlet. Minimum operating voltage is 110 volts. **Plugging the cord into an outlet of more than 128-volts will severely damage your system.**

If 2500-512DC scanners are used, there usually isn't a power cord at the bottom of the enclosure. If one is present, don't plug it into an outlet, because the heaters in these scanners use 12 VDC.

### 2.1.1 System-Interconnect Board (2300-106)

The System-Interconnect board provides connection points for incoming and outgoing wiring. Most wiring to this board is from the surge-protection panel, which is the entry point for the transducers, auxiliary-alarm detectors, shielded temperature probe, telephone line, and DC power. Other wiring to this board is from the chassis-mounted connectors located on the SmartScanNG<sup>2</sup> enclosure. These connectors are provided for the external speaker, external radio, bearing and wheel scanners, and radio antenna.

Only a few electronic components are located on the System-Interconnect board. Most of them are associated with power distribution. DC power from the System-Interconnect board is routed to the Interface board, shielded temperature probe, internal radio, bearing scanners, and wheel scanners. Much of the DC power originates from a common source before branching out to various destinations. The board fuses each DC branch with a self-restoring fuse. This prevents a malfunction in a single device from bringing down a larger portion of the system. A tripped fuse remains in the tripped state until the overcurrent condition is corrected. There are 10 individually fused 12-VDC branches. Four provide power to the bearing and wheel scanner electronics. Four provide power to the bearing and wheel scanner protective-shutters. One provides power to the optional internal radio. One provides power to the optional SOTC board.

Scanners use three sources of power. The scanner circuitry uses 12 VDC, which is protected by one self-restoring fuse per scanner. The scanner shutters use 12 VDC, which is switched by a single solid-state relay (on the relay panel), protected by one self-restoring fuse per shutter, and indicated with signal activation LEDs. The heaters in the 2500-512**AC** scanners use 120 VAC, which is switched by a single solid-state relay (on the relay panel), protected by a circuit breaker on the bottom of the SmartScanNG<sup>2</sup> enclosure, and indicated with signal activation LEDs. The heaters in the 2500-512**DC** scanners use 12 VDC, which is switched by a single solid-state relay (on the relay panel), protected by one circuit breaker, and indicated with a signal activation LED.

## 2.1.2 Controller Module (2300-602)

The Controller module is the brains of the SmartScanNG<sup>2</sup> system. It contains the Interface board, the display panel, and the optional Velocity Modem board. For ease of maintenance, the module detaches from the SmartScanNG<sup>2</sup> enclosure as a separate unit. It is easily removed by first unplugging the Molex and ribbon cable connectors and then by removing the fasteners.

Communications with the controller module can be established locally via:

- Serial Interface through local comm port
- WiFi Interface (wireless connection)
- Display panel/keypad on front of controller module

Communications with the controller module can be established remotely via:

- Web Interface with internet connection
- Serial Interface through Telnet connection
- Serial Interface through hardline or cellular modem

The figure below shows the major parts of the Controller module (2300-602).

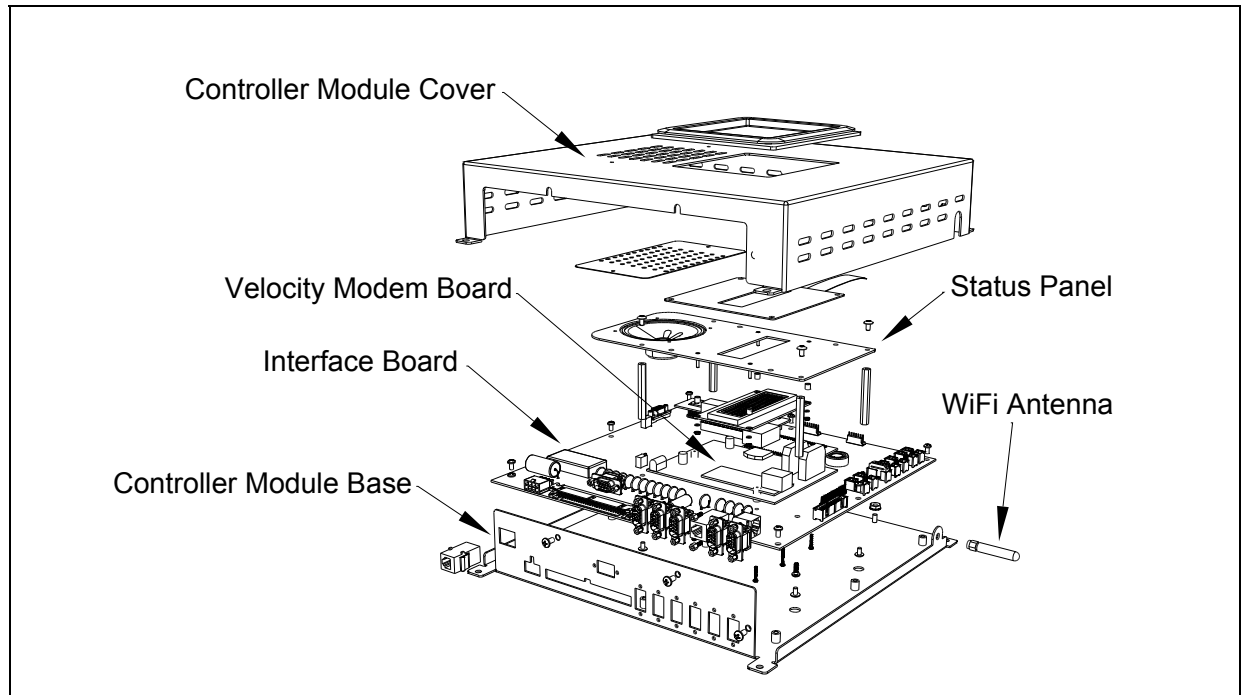

## 2.1.2.1 Display Panel

Located on front of the SmartScanNG<sup>2</sup> Controller Module is the Display Panel. Its status indicators and display module provide a snapshot of the overall system health. As a convenience, the Display Panel also provides a user interface to execute some frequently used system functions (i.e. Auto Cal, Radio Test, etc.).

The display panel consists of 6 LEDs, a keypad, and an LED display as shown below.



LED	Meaning when Lit
TO1	Indicates wheel sensor TO1 is active.
TO2	Indicates wheel sensor TO2 is active.
COP-A	Indicates the status of Processor-A. If the CPU is running its program correctly, the LED blinks on and off. If the program isn't operating as expected, the LED is lit solid, or isn't lit at all.
COP-B	Indicates the status of Processor-B. If the CPU is running its program correctly, the LED blinks on and off. If the program isn't operating as expected, the LED is lit solid, or isn't lit at all.
PTT	Indicates the radio PTT is active.
SYS WARN	Indicates a system warning has been detected.

Keypad Switch	Function
FUNC	The function key toggles from home screen to the Main Menu. It also serves as "Back" key in the system submenus to return to the previous menu level.
▼ (Arrow Down)	Scroll down menu options.
▲ (Arrow Up)	Scroll up menu options.
SELECT	Selects highlighted menu option.
RESET	Initiates system reset.

## LED Display:

The display assembly includes a 4-line 20-character OLED display and a five key membrane switch panel. If unused for five minutes, the display will time out to conserve power. Press any key to turn the display back on.

The home screen displays milepost, time, and temperature.

```
MP 1234.5  02:05:39
              Temp: 72
```

If a system warning has been detected, the display will indicate “Check Sys. Health Menu” at the bottom of the screen.

## Menu Navigation:

- Press the **FUNC** key to toggle from home screen to the Main Menu or to back out of the various submenus.
- Use the **▲UP** and **▼DOWN** keys to move the **▶** pointer next to the desired menu option.
- Press the **SELECT** key to choose the menu option. The “↓” symbol on the display screen indicates that there are more options available if you scroll down. Likewise, the “↑” symbol indicates more options are available if you scroll up.

```
Main Menu
  Sys. Health Menu
  ▶Reset Sys. Health
  ↓ Radio Test
```

## System Health Menu

The System Health Menu provides a snapshot of the system’s general health. Each system health check displays a status of “GOOD” or “BAD” based on trending information derived from system alarms, integrity failures, and other monitored data. If a system warning has been flagged, the **SYS WARN** LED will be lit and the “Check System Health” message will be displayed on the bottom text line of the home screen.

1. From the Main Menu, place the **▶** pointer next to **Sys. Health Menu**.

```
Main Menu
  ▶Sys. Health Menu
  Reset Sys. Health
  ↓ Radio Test
```

2. Press the **Select** key to display the status of the various system health checks such as NumTrains, LowMiscount, HighMiscount, AvgTemp0, AvgTemp1, AvgTemp2, AvgTemp3, ColdRail0, ColdRail1, ColdRail2, ColdRail3, Avg Miscount, and Batt. prcnt.

```
Sys. Health Menu
▶NumTrains      Good
  LowMiscount   Good
↓ HighMiscount  Good
```

If any of these system health checks indicate a “Bad” status, select that item to display more detailed information.

3. To reset system health, navigate to the Main Menu and place the ▶ pointer next to the **Reset Sys. Health**.

```
Main Menu
  Sys. Health Menu
▶Reset Sys. Health
↓ Radio Test
```

4. Press the **Select** key. When prompted, select **Yes** to reset system warnings and zero all health check counts.

```
Are You Sure?
▶Yes
  No
```

## System Functions

Several system functions can be performed from the display panel. Available options are:

- System Health Menu
- Reset System Heath
- Radio Test
- Auto Cal
- Network Menu
- Radio Menu
- Volume Menu

## Radio Test

To perform a radio test, go to the Main Menu and select **Radio Test**.

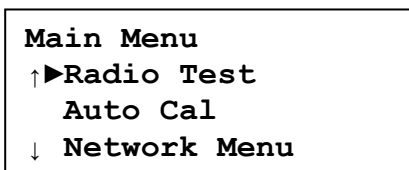

The Radio Test option is used to broadcast a short message through the speaker and through the radio. Using this option lets you verify that the speaker and radio are working properly.

At single-track sites, the text of the message is "Testing, (*railroad name*), milepost, (*milepost number*), testing, one, two, three, four, five, four, three, two, one, testing." At double-track sites, the text of the message is "Testing, (*railroad name*), milepost, (*milepost number*), track (*track designation*), testing, one, two, three, four, five, four, three, two, one, testing."

If the system isn't currently making any other voice announcements, it begins the Radio Test announcement. After the announcement finishes, the System Functions menu reappears.

If the system is currently making a voice announcement, the firmware displays the message "System Is Currently Making Voice Announcements! Try Again Later" and redisplay the System Functions menu.

While listening to the message, look at the PTT LED on the display panel.

The **PTT LED** should be lit. If this LED isn't lit, the system's ability to send a message to the radio might be inhibited by the Radio Inhibit option on the System Functions menu. If the radio is inhibited, the results of this check are invalid.

## Auto-Calibration

The SmartScanNG<sup>2</sup> system self-calibrates its pyrometer interface circuitry. You need only put a preheated calibrated heat source on a scanner and place the system in autocalibration mode. The system then scans all pyrometer inputs until the signal from the calibrated heat source is located. The necessary adjustments to the related interface circuitry are automatically made while the system monitors its own progress by analyzing changes in the heat signals.

From the Main Menu, select **Auto Cal**. This prompt appears.

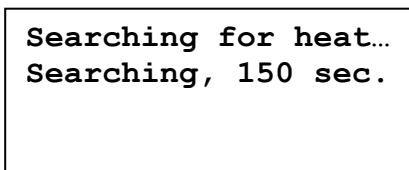

Once the procedure has been completed, autocalibration mode is disengaged and the calibration results are displayed.

For a detailed description of the auto-cal procedure, go to **Section 8.5 Calibrating Scanners**.

## Network Menu

The Network Menu allows for the viewing the various network settings. It also offers the ability to toggle certain setting on or off (i.e. Wifi and DHCP).

From the Main Menu, select the **Network Menu** option.

Available options are:

DHCP server, Wifi (on/off), IP Address, DHCP (on/off), TELNET port, HTTP port, and HTTPS port

## Radio Menu

From the Main Menu, select **Radio Menu** to view the radio screen. This screen will display certain radio status information such as:

- “PTT Disabled” if Radio Inhibit is active
- “Holdoff Active” if holdoff is enabled
- “CD active” when radio has detected an active carrier signal

Press SELECT key to initiate Radio Test.

## Volume Menu

From the Main Menu, select **Volume Menu** to view/change speaker volume.

```
Vol: 5 [||||| ]
Up/Down = change
Select = Radio test
Func = Back
```

There are ten volume settings (0 – 9) with level 9 being maximum volume. Press the ▲UP key to increase volume level. Press the ▼DOWN key to decrease volume level.

Pressing the **SELECT** key while in Volume Menu will initiate a radio test.

The Radio Test is used to broadcast a short message through the speaker and through the radio. Using this option lets you verify that the speaker volume is at a sufficient level. At single-track sites, the text of the message is "Testing, (*railroad name*), milepost, (*milepost number*), testing, one, two, three, four, five, four, three, two, one, testing." At double-track sites, the text of the message is "Testing, (*railroad name*), milepost, (*milepost number*), track (*track designation*), testing, one, two, three, four, five, four, three, two, one, testing."

Press the **FUNC** key to back out of menu.



## 2.1.2.2 Processor Modules

Running programs written by STC, the processor modules control the entire SmartScanNG<sup>2</sup> system. There are two independently operating processor modules, the Analyzer Processor and the Communications Processor. The Analyzer Processor (Processor-A) is responsible for data retrieval from external sources, such as the shielded temperature probe, scanners, transducers, and auxiliary devices. The Communications Processor (Processor-B) is used to process and store the retrieved data. It then presents information to the user in the form of reports.

Processor-A initially stores train data in static random-access memory (SRAM) on the processor module. After train passage, Processor-B moves this data to a nonvolatile Flash memory for longterm storage. This memory contains:

- The Trains directory, which contains data on each new train that passes the site. The Train Summary report and Train Detail report get their data from this directory.
- The Exceptions directory, which contains data on each train that has one or more Exception Alarms or System Alarms. The Exception Summary report and Exception Detail report get their data from this directory.

Each directory is organized as a circular buffer. In this scheme, data is added to the directory until the directory is full. Once full, the oldest data in the directory is overwritten as new data is recorded. The buffer for the Trains directory holds data on about 140,000 axles, but no more than 100 trains. The buffer for the Exceptions directory holds data on about 4,500 axles, but no more than 50 trains.

### 2.1.2.3 Interface Board (2300-110)

As its name implies, all of the interface and signal conditioning circuitry is located on the Interface board. This board connects to the System-Interconnect board with a 60-position ribbon connector and an 8-position Molex connector, which is shown below.

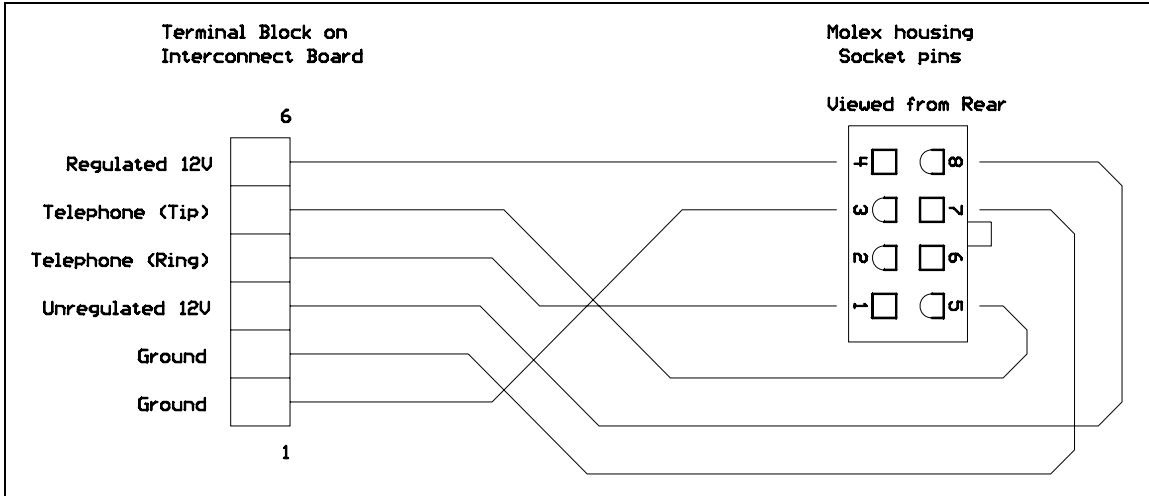

The board requires unregulated 12 VDC (battery voltage) to operate. The 12-VDC input power circuitry includes radio-frequency interference suppression, voltage surge protection, open fuse LED indicator, a self-restoring fuse, and reverse polarity protection. The board produces regulated -5 VDC, regulated +5 VDC, regulated +8 VDC, regulated +12 VDC, and regulated +15 VDC to power the on-board circuitry, modem, and external scanner circuitry.

The figure below shows the Interface board (2300-110). The board is shown as one would see it in service, which is the normal orientation for the board on a properly installed system.

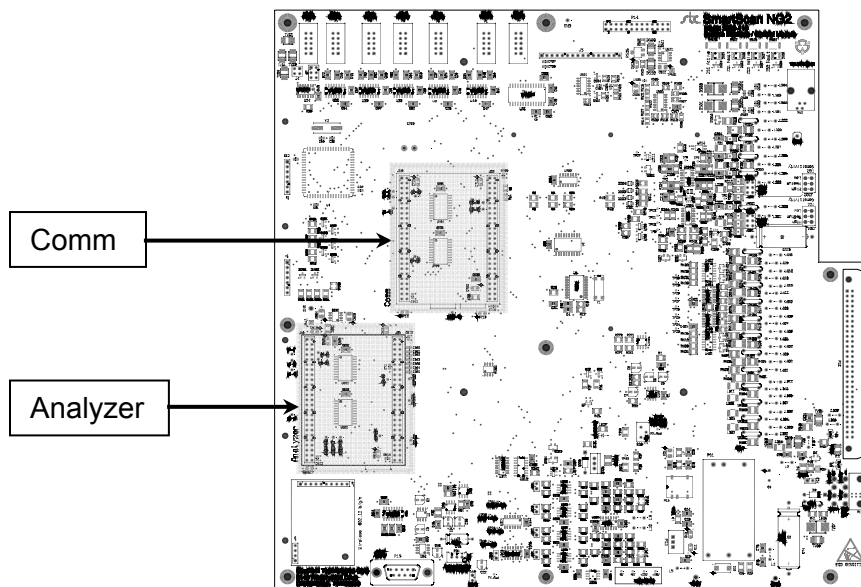

## Potentiometer R19

Potentiometer R19 adjusts the incoming touchtone volume. It is set at the factory and should not be changed by the customer.

## Potentiometer R34

Potentiometer R34 adjusts the audio level (modulation) going to the radio. A misadjusted level will be distorted or very weak sounding. This adjustment is set at the factory to FCC specifications. Turn R34 clockwise to increase the audio level. Turn it counterclockwise to decrease the audio level.

## LED 6

The Interface board (2300-110) has a red LED labeled **LED6**. This LED lights when the self-restoring fuse F1 opens due to an overcurrent condition on the +12-VDC supply voltage input.

## LED 7

The Interface board (2300-110) has a red LED labeled **Valid DTMF** (also labeled **LED7**). If R19 is adjusted properly, this LED lights as valid touchtones are received from the radio.

## LED 8

The Interface board (2300-110) has a red LED labeled **LED8**. This LED lights when the dragger (aka dragging-equipment detector) input activates.

## LED 9

The Interface board (2300-110) has a red LED labeled **LED9**. This LED lights when the high-load input activates.

## LED 10

The Interface board (2300-110) has a red LED labeled **LED10**. This LED lights when the wide-load-1 input activates.

## LED 11

The Interface board (2300-110) has a red LED labeled **LED11**. This LED lights when the wide-load-2 input activates.

## 2.1.2.4 Velocity Modem Board

The Velocity Modem board lets the system (at the site) communicate with a computer (away from the site).

The figure below shows a Velocity Modem board.

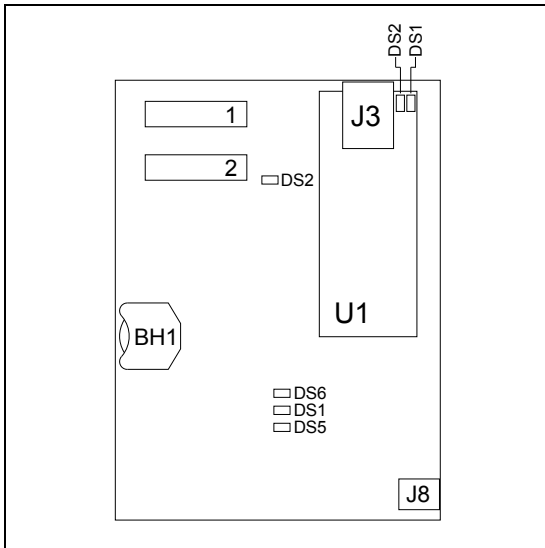

### Power Jack (J8)

The power jack is used to supply 9 VDC to the modem. At the factory, one end of a power cord was plugged into the power jack. The other end of the power cord was wired to **P13** on the Interface board.

### Port 1 Connector

The **Port 1** connector connects the Velocity Modem board to the rest of the system. At the factory, one end of a standard 10-position ribbon cable was plugged into **Port 1** on the Velocity Modem board. The other end of the ribbon cable was plugged into **P7** on the Interface board.

### Port 2 Connector

The **Port 2** connector connects the Velocity Modem board to outside world. **Port 2** on the Velocity Modem board is connected to **COM6** on the right edge of the Controller module. (You would normally plug your computer into **COM6** to access the modem's instruction set and database.)

## Battery (BH1)

During a power interruption to the Velocity Modem board, the on-board coin cell battery keeps the internal real-time clock running. During a power interruption, if this battery is low, dead, or missing, the stored time and date will be lost. However, no train data will be lost.

## Status LEDs

On the Velocity Modem board are 6 status LEDs. The table below describes what each lit LED means.

LED	Meaning When Lit
12V	Lights when the Velocity Modem board is getting adequate DC power from the SmartScanNG <sup>2</sup> system.
3.3V	Lights when the onboard 3.3-VDC regulator is working.
5V	Lights when the onboard 5-VDC regulator is working.
ACT	Flashes when there is activity on the Ethernet connection. That is, it flashes when sending or receiving data.
HB	Flashes once a second when the Velocity Modem board is running properly.
LNK	Lights when an Ethernet connection is made.

### 2.1.2.5 Controller Module Connector Panel

On the right side of a mounted Controller module (2300-602) are a group of connectors, as shown below.

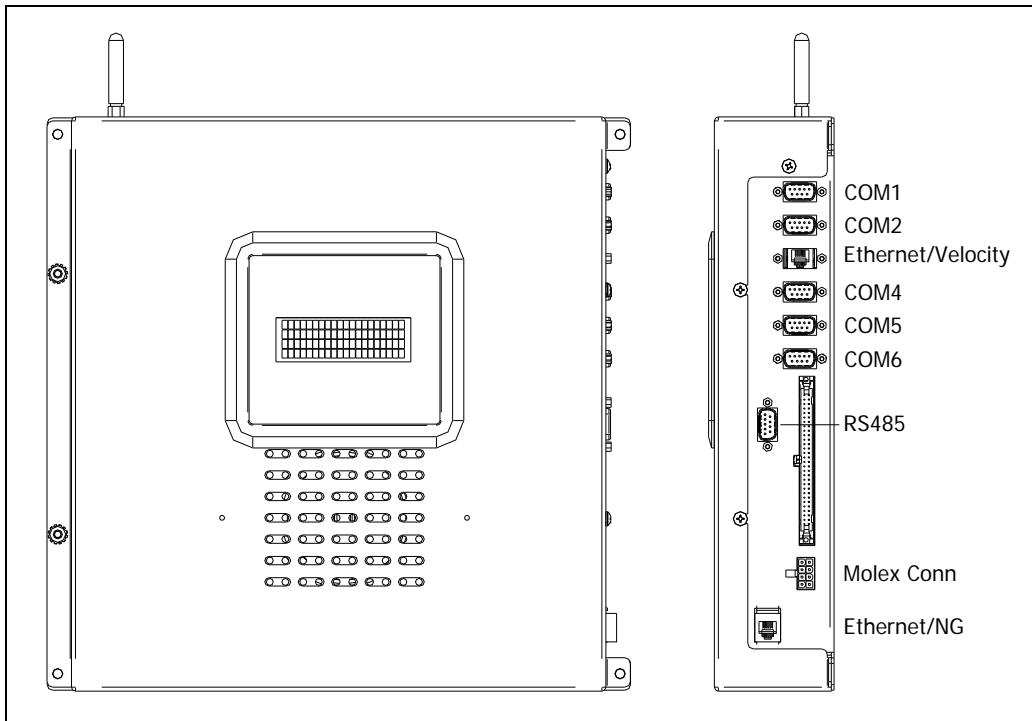

## Serial Ports

On the right side of a mounted Controller module are five serial ports. They are labeled COM1, COM2, COM4, COM5, and COM6.

The table below describes the use of each serial port and where on the Interface board (2300-105) it is attached.

Port	Use
COM1	Used to communicate with a customer-provided external device. At single-track sites, a computer is normally connected here. At double-track sites, a crossover (null-modem) cable is attached from <b>COM4 of system1</b> (that is, the system with an installed modem) to <b>COM1 of system2</b> (that is, the system <u>without</u> an installed modem). COM1 is connected to <b>P6</b> on the Interface board.
COM2	Used to communicate with a customer-provided external device. COM2 is connected to <b>P9</b> on the Interface board.
COM4	At double-track sites, a crossover (null-modem) cable is attached from <b>COM4 of system1</b> (that is, the system with an installed modem) to <b>COM1 of system2</b> (that is, the system <u>without</u> an installed modem). COM4 is connected to <b>P5</b> on the Interface board.
COM5	Used to connect AEI Interface module (2300-750) to the SmartScanNG <sup>2</sup> system. COM5 is connected to <b>P8</b> on the Interface board.
COM6	Used to communicate with the Velocity Modem board's instruction set and database. COM6 is connected to <b>Port 2</b> on the Velocity Modem board.

## Ethernet Connection (RJ45 Jack)

There are two Ethernet connectors on the right side of a mounted Controller module (2300-602). The Ethernet/Velocity (located between COM2 and COM4) and the Ethernet/NG (located at right-side bottom).

The **Ethernet/Velocity** connector is connected internally to the Velocity modem (if so equipped). The Velocity is a data harvesting tool that reports to central office systems.

The **Ethernet/NG** connector provides IP connectivity and allows for remote access via Telnet or Web User Interface.

### 2.1.3 SOTC Board (Zepic III)

If your system uses advance transducers for presence detection, skip ahead to next section.

The SOTC board tells the system when a train is present at the site. On the board is the blue calibration switch, which is used to adjust the gain control of the track circuit. See Section 8.6 Calibrating the Zepic III Presence Detector.

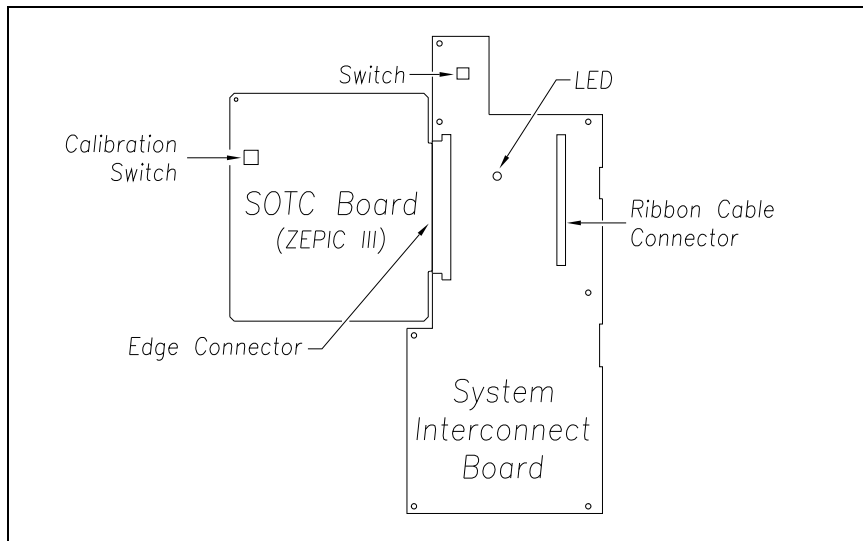

The SmartScanNG<sup>2</sup> enclosure only has a SOTC board if the site is using a track circuit. If the site is using two advance transducers, there is no SOTC board.

## 2.1.4 Surge-Protection Panel

Along with the surge suppressors found on the Interface board, the SmartScanNG<sup>2</sup> system employs a primary layer of surge suppression, which is located on the surge-suppression panel. This section of the SmartScanNG<sup>2</sup> enclosure forms a Faraday shield (that is, a grounded conducting enclosure). The purpose of the Faraday shield is to contain electromagnetic radiation.

Located inside are industrial grade surge suppressors (aka universal transient barriers or UTBs). They are capable of suppressing damaging electrical transients and surges, which can be induced onto signal lines by lightning. Here is a list of signals that pass through the UTBs on the surge-suppressor panel before entering the rest of the SmartScanNG<sup>2</sup> enclosure.

- Gating transducer **TO1**
- Gating transducer **TO2**
- Advance transducer **ADV1**, if used
- Advance transducer **ADV2**, if used
- Dragging-equipment detector **DED**
- High-load detector **HIGH**, if used
- Wide-load detector **WIDE1**, if used
- Wide-load detector **WIDE2**, if used
- Shielded temperature probe **TempProbe**, which uses two UTBs
- Telephone line **TeICo**, if used

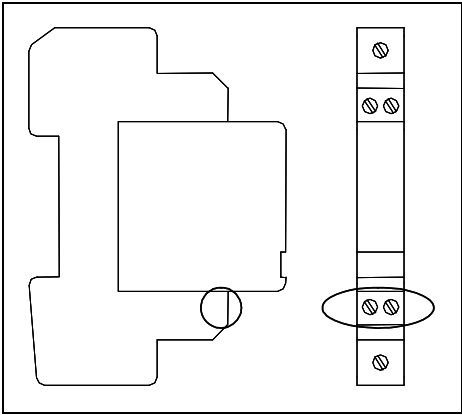

Each UTB is mounted horizontally on a DIN rail. Shown to the left are two views of the same UTB.

As you can see, there is one row of connectors on each side of the UTB.

The equipment listed above is wired to the bottom row of connectors.

## 2.1.5 Relay Panel

The SmartScanNG<sup>2</sup> system uses optically isolated solid-state relays (SSRs) to eliminate electromagnetic radiation, which would otherwise be generated by arcing of mechanical relay contacts. There are three SSRs mounted to the relay panel. One SSR operates the scanner shutters and another energizes the scanner heaters. The signals to activate the SSRs originate at the Processor board.

A third SSR is used to monitor and flag AC power failures. If AC power is disrupted, a message will be posted to the Event Log and “AC Power Off” will appear just before the menu header in the Serial Interface. If the AC power is off when a System Status report is requested, the message “AC Power Off” will be printed in the System Status report. If the AC power is off when a train passes the site, the message “AC Power Off” will appear in the System Alarms section of the Train Detail report.

The power rating for each SSR is intentionally overrated to ensure long-lasting reliability. For example, the SSR associated with the scanner **shutters** is rated for 100 VDC at 12 amps, even though the shutters operate on 12 volts and require less than 2 amps each. Likewise, the SSR associated with the **heaters** in the 2500-512**DC** scanners is rated for 100 VDC at 12 amps, even though the heaters operate on 12 volts and require less than 1 amp each. The SSR associated with the **heaters** in the 2500-512**AC** scanners is rated for 240 VAC at 25 amps of current, even though the heaters require only 120 VAC at 1.6 amps each.

## 2.1.6 Radio

Radios (aka RF transceivers) can be installed either internally or externally. Radios that are installed internally at the factory are usually Ritron synthesized VHF transceivers.

At double-track sites, there is usually one radio per track. This is the case when internal radios are used, but not always the case when external radios are used. When external radios are used, the components supporting **track2** don't have to have their own radio. Instead, they can use the radio that supports **track1**. (Using only one radio at a double-track site isn't covered in this guide. Call STC for help in doing this.)



The SmartScanNG<sup>2</sup> system provides the following connections to the radio.

- Regulated 11.5-VDC power supply, which is internally fused with a self-restoring fuse at 2.5 amps
- PTT signal to the radio, which allows the SmartScanNG<sup>2</sup> system to key the radio before transmission
- Adjustable audio level to the radio for verbal messages to the train crew
- Adjustable audio level from the radio for DTMF detection, which allows the train crew to request rebroadcasts
- Hold-off signal (carrier detect) from the radio, which prevents transmissions while the channel is busy
- Channel select to the radio, which allows firmware control channel selection of two channels
- Eight channel selector switch located on the System-Interconnect board
- Coaxial surge arrester for the antenna connection, which is located inside the SmartScanNG<sup>2</sup> enclosure

## 2.1.7 Other Components

On the outside of the SmartScanNG<sup>2</sup> enclosure are connectors, LEDs, and other components.

On the **top edge** of the enclosure are:

- Antenna connector, when applicable
- Speaker with volume control (optional)
- Speaker jack

On the **bottom edge** of the enclosure are:

- Four scanner connectors
- AC power cord for powering the scanner heaters, when applicable
- Circuit breaker for scanner heaters

On the **right-side edge** of the enclosure are:

- On/off DC power switch
- External radio connector
- Chassis mounted LEDs

### 2.1.7.1 DC Power Switch

The SmartScanNG<sup>2</sup> enclosure doesn't have an AC power switch and needs to be disconnected from its AC power source to stop AC from entering the enclosure. However, it does have a DC power switch on the right-side edge of the enclosure. When it is toggled off, all DC power to the SmartScanNG<sup>2</sup> enclosure is stopped.

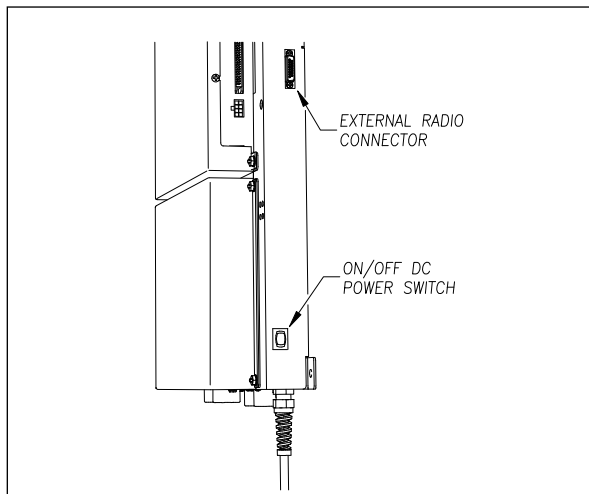

### 2.1.7.2 External Radio Connector

The external radio connector is a DB15 connector. The signals that are used have the same pin-out as the internal radio connector. Located on the System-Interconnect board is an 8-position channel selector switch, which controls pins 1-3 in a binary fashion. Pin-5 and pin-1 are the same electrical connection, which also connects to a digital output from the Processor board. When channel zero is selected with the channel selector switch, the processor can select either channel-0 or channel-1. Software that supports processor controlled channel selection is optional.

Pin-6 provides regulated 11.5 volts at 2.5 amps. This is appropriate for the Ritron radio, but not for larger radios requiring more power. It is advisable to use another means to power such radios.

Pin-7 provides audio output from the SmartScanNG<sup>2</sup> system to an external radio. The audio level is adjustable using potentiometer R34, which is located on the Interface board. Pin-12 provides audio input to the SmartScanNG<sup>2</sup> system (from the external radio) when the rebroadcast function is used.

Pin-13 is the carrier-detect input to the SmartScanNG<sup>2</sup> system. This signal is internally pulled high. A low level prevents the SmartScanNG<sup>2</sup> system from initiating a voice transmission.

Pin-14 is the PTT output from the SmartScanNG<sup>2</sup> system. This is an open-collector, active low signal, which is grounded while the SmartScanNG<sup>2</sup> system is transmitting.

Pin-15 is ground. Pins 4, 8, 9, 10, and 11 aren't used.

### 2.1.7.3 Chassis Mounted LEDs

There is a group of four status LEDs on the lower right side of the chassis. These LEDs show the operation of the solid-state relays used to control the scanner shutters and heaters. They can also indicate problems with the relays if they fail to operate. All four of these LEDs are green. Two of the LEDs are wired directly to the relays input terminals to indicate when a control signal has been sent from the controller. The other two LEDs are wired to the relay output to indicate when power is being applied to the scanner.

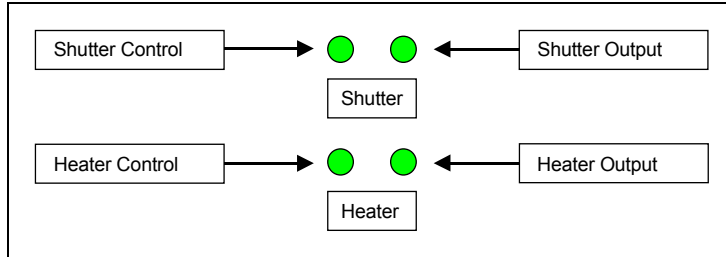

Not all four LEDs can be lit at the same time. Anytime the shutters are open, the heaters should be off. Under normal conditions, the top two LEDs (shutters) should only be lit when the heaters are off. Conversely, under normal conditions, the bottom two LEDs (heaters) should only be lit when the shutters are closed. In other words, when the system is working, only the top two LEDs are lit when a train is rolling through the site. When no train is present, only the bottom two LEDs may be lit.

The LEDs can indicate that the relay has failed to activate when a control signal is applied, as shown in the table below. In the table, a shaded area means that an LED is lit. An unshaded area means that an LED isn't lit. Only seven of the possible combinations of lit LEDs are listed below. All other combinations are invalid and indicate a system problem.

Shutter Control LED	Shutter Output LED	Heater Control LED	Heater Output LED	Explanation
On	Off	Off	Off	Invalid. The shutters are being commanded to open, but the relay isn't responding with shutter voltage.
On	On	Off	Off	Normal if a train is present. Invalid if a train isn't present.
Off	On	Off	Off	Invalid. No shutter signal, but shutter voltage is present.
Off	Off	On	On	Normal if a train isn't present and the outside temperature is cold. Invalid if a train is present or if the outside temperature is warm.
Off	Off	On	Off	Invalid. The heaters are being commanded to turn on, but the relay isn't responding with heater voltage.
Off	Off	Off	On	Invalid. No heater signal, but heater voltage is present.
Off	Off	Off	Off	Normal if a train isn't present and the outside temperature is warm. Invalid if a train is present or if the outside temperature is cold.



## 3.0 Power Subsystem

### 3.1 Power Subsystem

The figure below shows the major parts of the power subsystem powered from an AC power source.

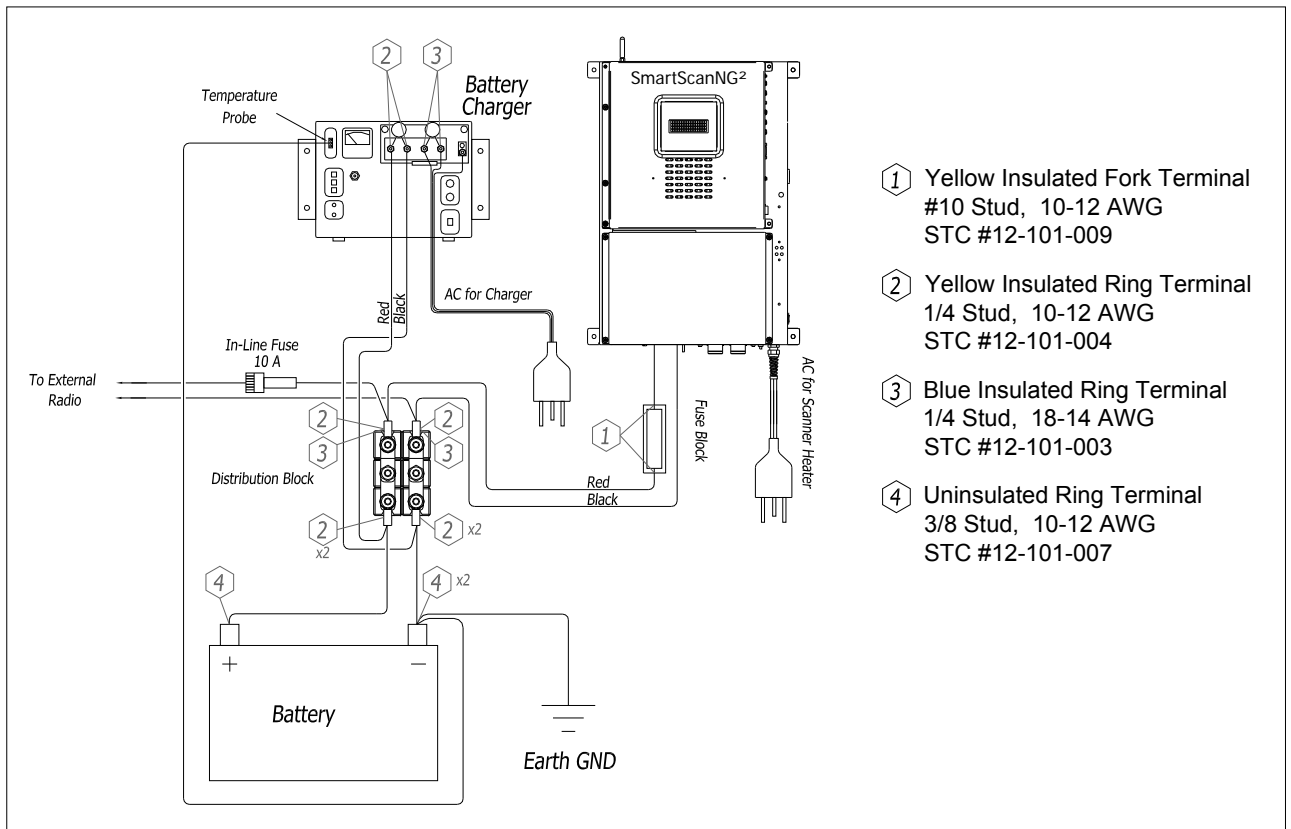

There is one SmartScanNG<sup>2</sup> enclosure per track, one power subsystem per SmartScanNG<sup>2</sup> enclosure, and one battery per power subsystem. One battery charger per battery.

### 3.2 Battery

Each SmartScanNG<sup>2</sup> enclosure uses one 12-volt 115-ampere-hour battery. The use of a smaller battery reduces the amount of time that the SmartScanNG<sup>2</sup> system can continue to operate after AC power is removed.

### 3.3 Battery Charger

The figure below shows the front of a NRS ELC-12/20-D battery charger.

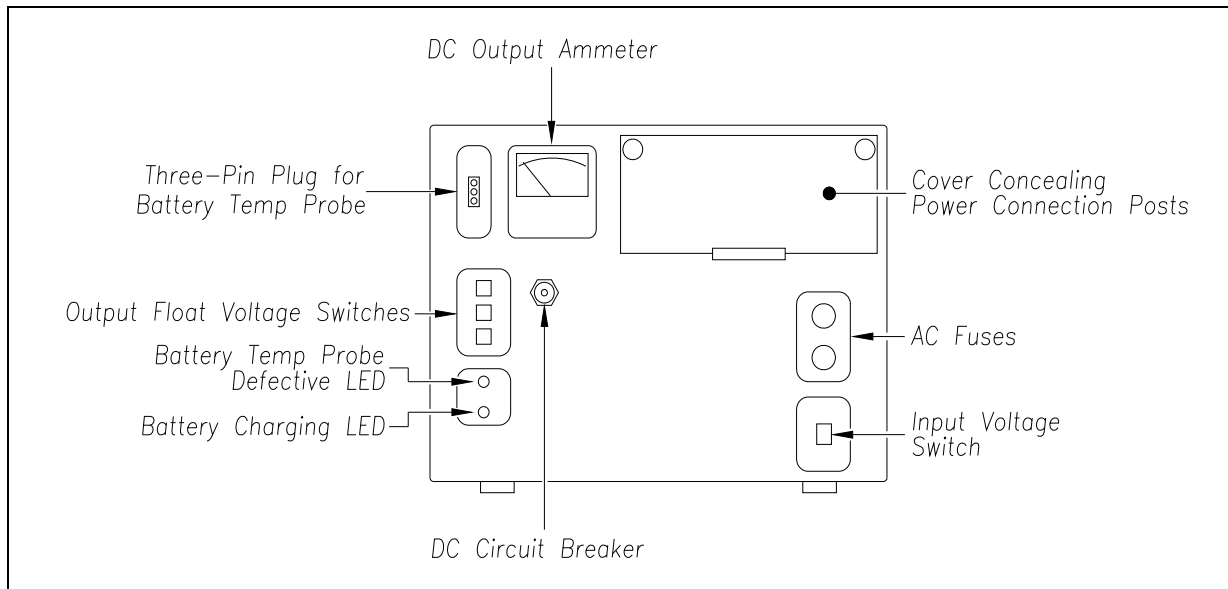

The input voltage switch can be set to 115 VAC or 230 VAC. Use 115 for input voltages between 108 and 128. Use 230 for input voltages between 216 and 256.

The output float voltage switches can be set so that a battery is charged within the range 10.00 VDC and 17.00 VDC. The **factory default is 14.00 VDC**. To reset the switches, use a small slotted screwdriver to turn each switch to the desired number. Be sure that each switch is set on a number and not between numbers. The ten's digit is always 1 and can't be changed. The top switch controls the unit's digit. The middle switch controls the tenth's digit. The bottom switch controls the hundredth's digit. Thus, to select 13.68 VDC, turn the top switch to 3, the middle switch to 6, and the bottom switch to 8.

If the battery temperature probe is defective or not installed, the red defective LED is lit. If the battery is charging properly, the yellow battery-charging LED is lit. If one or more of the output float voltage switches is set between numbers, the yellow battery-charging LED flashes.

Above the input voltage switch are two 4-amp 250-volt fast-acting fuses. They protect the battery charger from excessive AC. To the right of the output float voltage switches is a circuit breaker. It protects the battery charger from excessive DC.

You can open the small door on the front of the charger by pulling out the push tabs. Doing so reveals the power connection posts, as shown below.

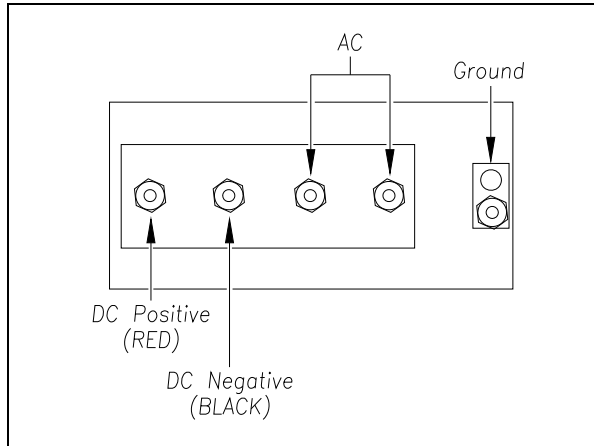

### 3.4 DC Power Distribution

DC power distribution consists of a distribution block and a fuse block, which is shown below. There is one of each of these components per SmartScanNG<sup>2</sup> enclosure.

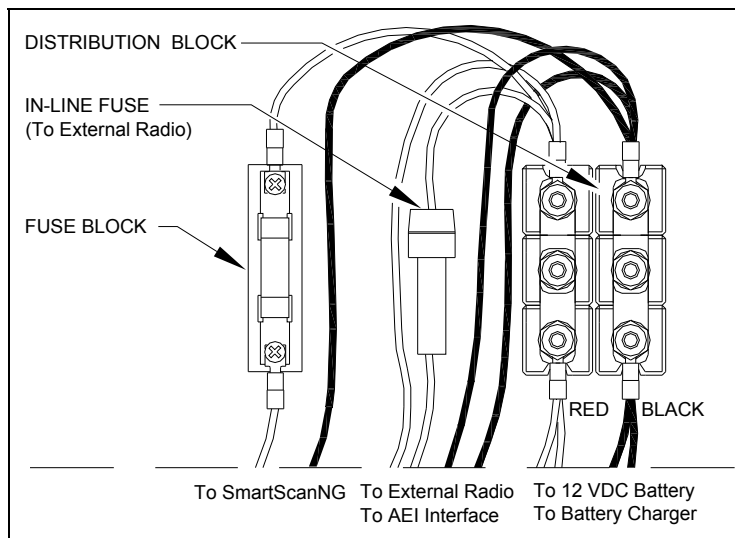

The **distribution block** contains six terminals. Loosening the middle gold nuts will disconnect DC power to the rest of the system. Wires from the bottom of the distribution block go to the 12V battery and to the battery charger. Wires from its top go to the fuse block, to the AEI Interface, and to the external radio.

The **fuse block** contains a standard 13/32 x 1-1/2-inch, 25-amp, fast blow fuse. The fuse provides overload protection for the SmartScanNG<sup>2</sup> enclosure. The equipment side of the fuse block is connected to the surge-suppression panel inside the SmartScanNG<sup>2</sup> enclosure. The battery side of the fuse block is connected to the battery via the distribution block.





## 4.0 Shielded Temperature Probe

---

The temperature probe is encased in a radiation shield that shields it from direct sunlight and allows ambient air to flow through and around it. The probe mounts to the outside wall of the wayside enclosure and provides accurate temperature indications over a range of  $-45^{\circ}\text{C}$  to  $+65^{\circ}\text{C}$  ( $-49^{\circ}\text{F}$  to  $+149^{\circ}\text{F}$ ). Site ambient temperature (when the train passed the site) is included with most system reports. There is one shielded temperature probe per system.

The figure below shows the major parts of a shielded temperature probe (2090-100).

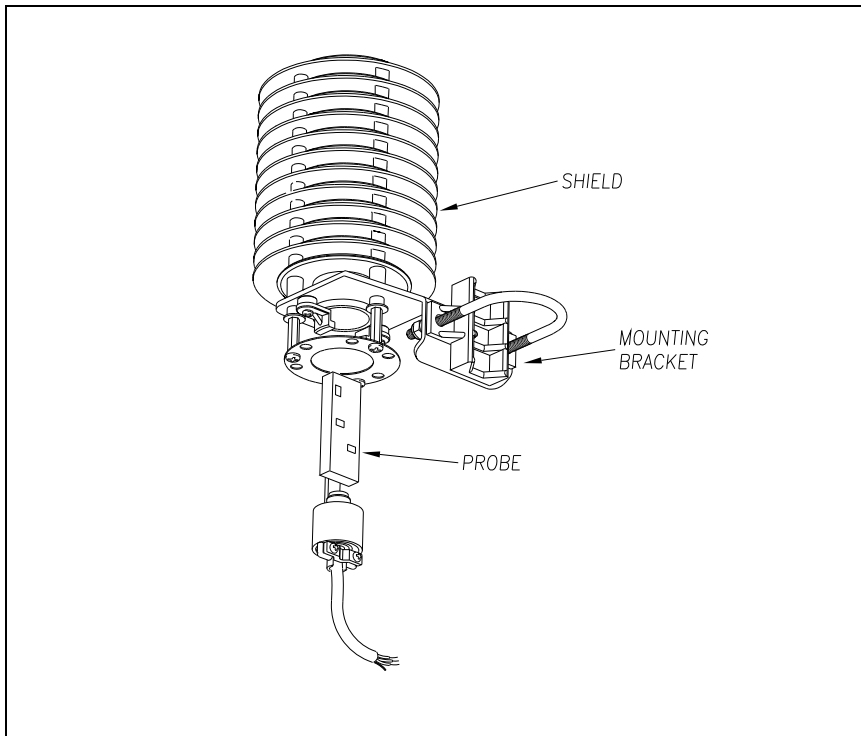

The SmartScanNG<sup>2</sup> system supplies 12 volts to the shielded temperature probe. The probe returns 0 to 5 volts. Zero volts indicate a  $-45^{\circ}\text{C}$  ( $-49^{\circ}\text{F}$ ) reading. Five volts indicates a  $+65^{\circ}\text{C}$  ( $+149^{\circ}\text{F}$ ) reading. During normal operation, you should probably never get either reading. Therefore, if you get a  $-45^{\circ}\text{C}$  ( $-49^{\circ}\text{F}$ ) reading, the probe could be malfunctioning, the cable from the probe to the SmartScanNG<sup>2</sup> enclosure could be cut, or the wiring to the System-Interconnect board could be disconnected. If you get a  $+65^{\circ}\text{C}$  ( $+149^{\circ}\text{F}$ ) reading, the probe could be malfunctioning or the ground wire from the probe to the SmartScanNG<sup>2</sup> enclosure could be cut.

The system comes with a partially installed shielded temperature probe. **Section 7.12 - *Shielded Temperature Probe*** tells how to finish installing it.



## 5.0 AEI Subsystem

---

Not all SmartScanNG<sup>2</sup> detectors incorporate an AEI subsystem. If your SmartScanNG<sup>2</sup> system does not, skip ahead to section 6.0. The AEI subsystem consists of two AEI antennas and a reader module. Described below are the optional AEI readers - the 2300-750 and the 2300-752.

### **NOTICE:**

If equipped with an AEI subsystem, the user is required to obtain a Part 90 site license from the FCC to operate in the United States. See product label for FCC ID number. Access the FCC Web site at [www.fcc.gov/Forms/Form601/601.html](http://www.fcc.gov/Forms/Form601/601.html) for additional information concerning licensing requirements.

Users in all countries should check with the appropriate local authorities for licensing requirements.

### 5.1 2300-750 AEI Interface Module

The AEI Interface module contains a Transcore AR2200 RF unit and a Transcore AI1200 Reader Logic board. The AR2200 has a single RF output that is multiplexed between two antenna connections (ant0 and ant1). One or both antennas can be enabled via setup commands.

The AEI Interface module reads and reports Radio Frequency Identification (RFID) tags in the original programmed format. It can also decode owner's initials, equipment number, and side indicator of tags that are in the Association of American Railroads (AAR), International Standardization Organization (ISO), or American Trucking Association (ATA) data format.

Commands are used to control the operation of the AEI Interface module. Setup commands are sent from the Processor board (2300-100) at power startup to configure the operating parameters of the AEI Interface module. When a train arrives at the site, the AEI Interface module "wakes up." It then starts reading AEI tags from the passing train. The information from these tags is sent to the Processor board as the tags are read. The AEI Interface module appends a timestamp to each tag record that indicates when the tag was read. After a train has left the site, the timestamp is used to match each tag to a vehicle in the train's consist.

The Train Detail report displays the AEI information of each vehicle in the train's consist from which a tag was read. The Train Summary report displays a total tag count for each train.

The figure below shows an assembled AEI Interface module (2300-750).

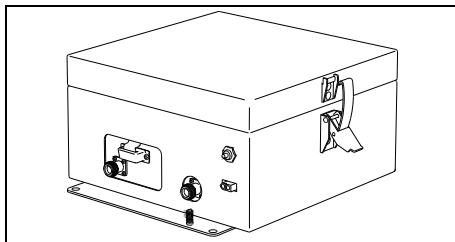

The figure below shows the major parts of an AEI Interface module (2300-750).

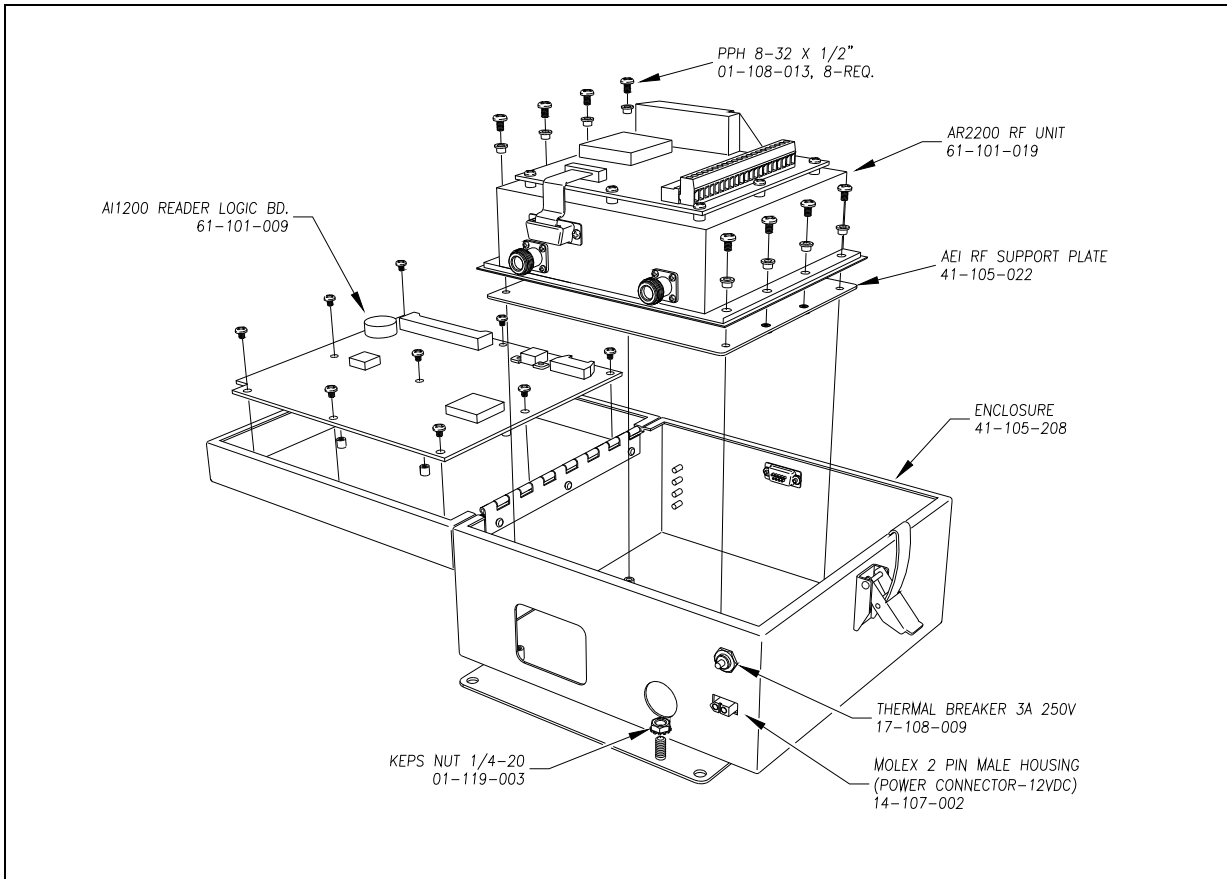

### 5.1.1 Components on Outside of Module

On one side of the AEI Interface module are two N-type antenna connectors, a 2-pin 12-VDC connector, a 3-amp 250-volt thermal breaker, and a ground connector. On other side are four LED status indicators and a serial communications port (Dsub9 connector), which is used to connect to the COM5 of the Controller module (2300-602).

The figure below shows the location of the LEDs.

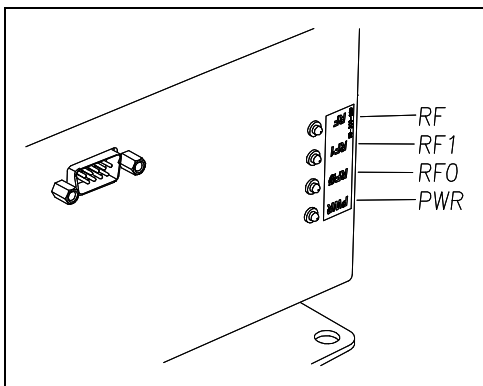

The table below describes what each lit LED means.

LED Name	LED Color	Meaning When Lit
PWR	Green	Proper voltage is present. Stays lit as long as the AEI Interface module is powered up.
RF	Green	RF Lock is active.
RF0	Green	RF power to antenna0 is "ON."
RF1	Green	RF power to antenna1 is "ON."

### 5.1.2 Components on Transcore AR2200 Board

The AR2200 provides a range-sensitivity adjustment feature that allows unwanted tag signals to be screened without decreasing RF power. Potentiometers "Range Mod Adjust Antenna0" and "Range Mod Adjust Antenna1" are used to desensitize the read range of antenna0 and antenna1 respectively. Jumper J3, when shorted, inhibits range adjust potentiometers.

For some installations, it may be necessary to attenuate RF power in conjunction with range-sensitivity adjustment in order to achieve the optimal read range.

## 5.2 2300-752 MPRR Panel

The 2300-752 MPRR Panel is a prewired, wall mountable panel assembly consisting of an MPRR, a boost converter, coaxial surge arresters, and a DB9 breakout board.

The MPRR reads and reports Radio Frequency Identification (RFID) tags in the original programmed format. It can also decode owner's initials, equipment number, and side indicator of tags that are in the Association of American Railroads (AAR), International Standardization Organization (ISO), or American Trucking Association (ATA) data format.

Commands are used to control the operation of the MPRR. Setup commands are sent from the Processor board (2300-100) at power startup to configure its operating parameters. When a train arrives at the site, the MPRR "wakes up." It then starts reading AEI tags from the passing train. The information from these tags is sent to the Processor board as the tags are read. The MPRR appends a timestamp to each tag record that indicates when the tag was read. After a train has left the site, the timestamp is used to match each tag to a vehicle in the train's consist.

The Train Detail report displays the AEI information of each vehicle in the train's consist from which a tag was read. The Train Summary report displays a total tag count for each train.

## 2300-752 MPRR Panel

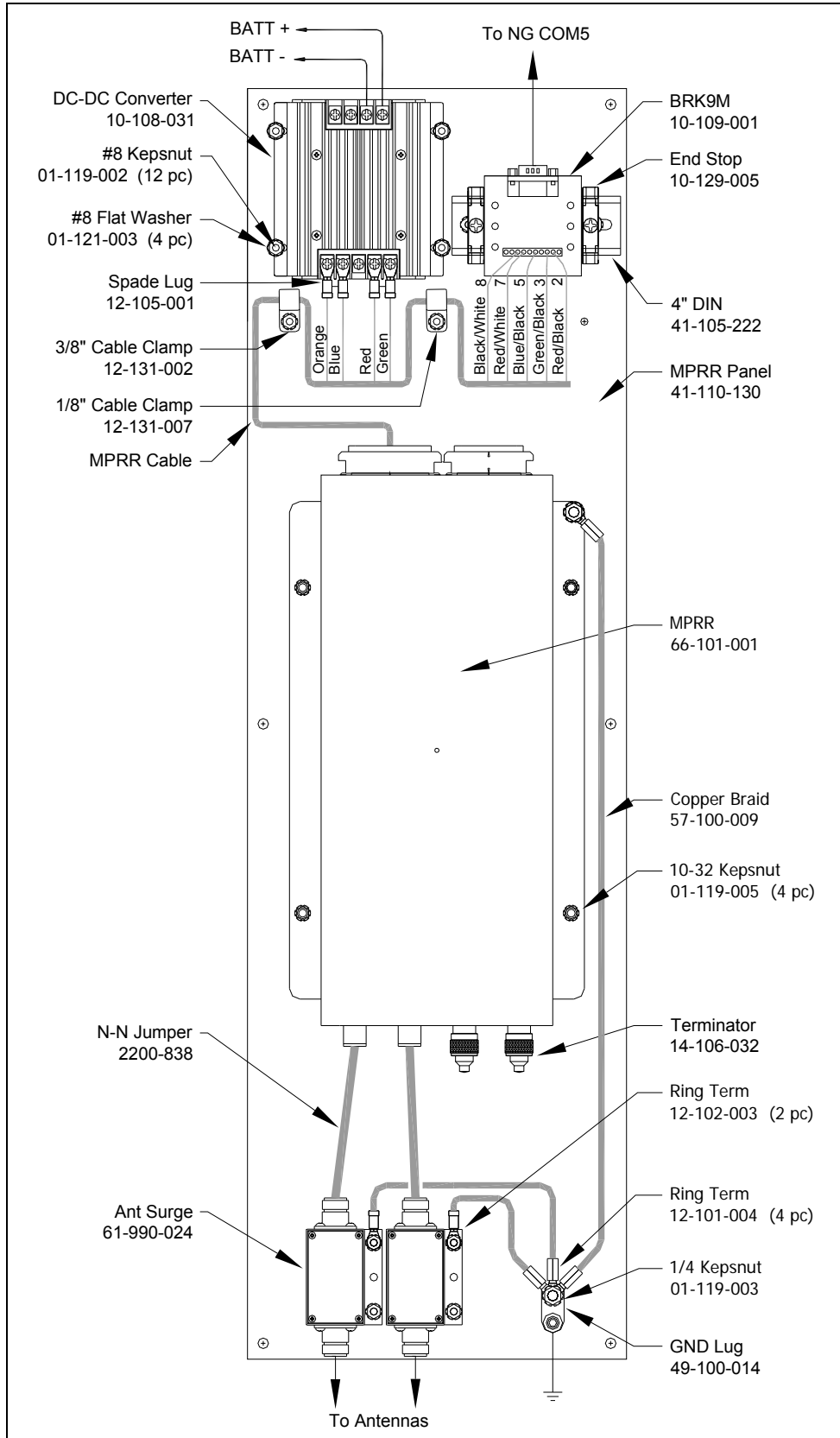

## 5.2.1 MPRR

TransCore's Multiprotocol Rail Reader (MPRR) is a fully integrated, self-contained 902- to 928-MHz wireless radio frequency identification (RFID) reader that is specifically designed for rail applications. The MPRR is the recommended replacement reader for TransCore's AI1200 Reader/AR2200 RF Module systems.

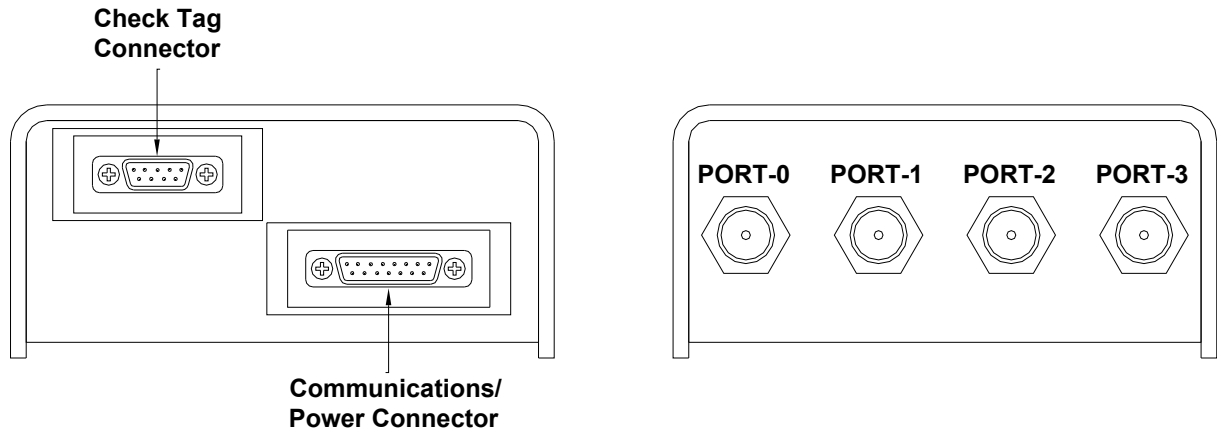

Power and serial communications are brought in through the DB15F connector.

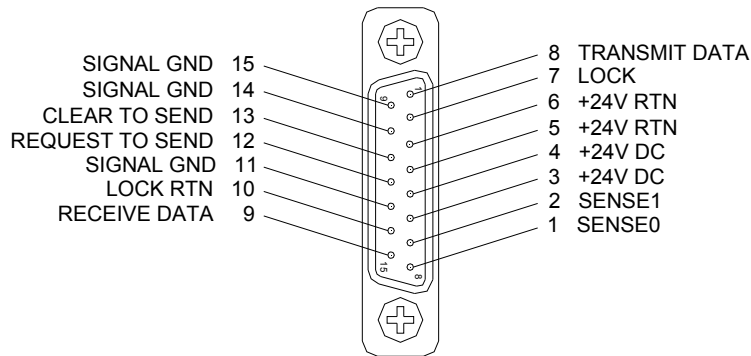

MPRR Cable Assignments		
Pin No.	Color	Signal
1	Black	Sense0
2	White	Sense1
3	Red	+24V DC
4	Green	+24V DC
5	Orange	+24V RTN
6	Blue	+24V RTN
7	White/Black	Lock
8	Red/Black	Xmit Data
9	Green/Black	Rec Data
10	Orange/Black	Lock RTN
11	Blue/Black	Signal GND
12	Black/White	RTS
13	Red/White	CTS
14	Green/White	Signal GND
15	Blue/White	Signal GND

Power Supply Current Requirements:

Supply	(RF On) Worst Case Maximum Current at 68°F	(RF Off) Standby Operating Current at 68°F
16 to 20V AC	1.7 A at 18V AC	1 A at 18V AC
16 to 28V DC	1.7 A at 18V DC	1 A at 18V DC

The MPRR has a single RF output that can be multiplexed with up to four antennas. Unused antenna ports should be terminated into a 50 Ohm terminator.

### 5.2.2 DC-DC Converter

The 24V 2.08A boost converter provides power to the MPRR. It operates from an input voltage of 9 ~ 36 VDC.

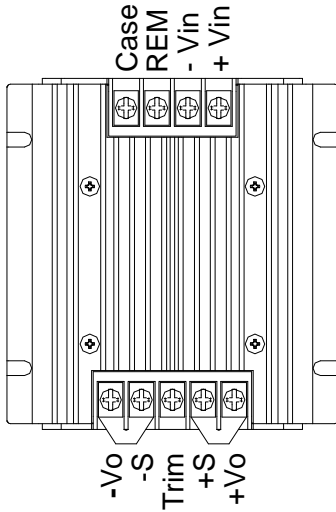

### 5.2.3 DB9 Breakout Board

RS232 serial communications to MPRR are provided through the DB9M connector. A standard DB9F to DB9F straight serial cable connects the MPRR panel to COM-5 of the SmartSCAN-NG.

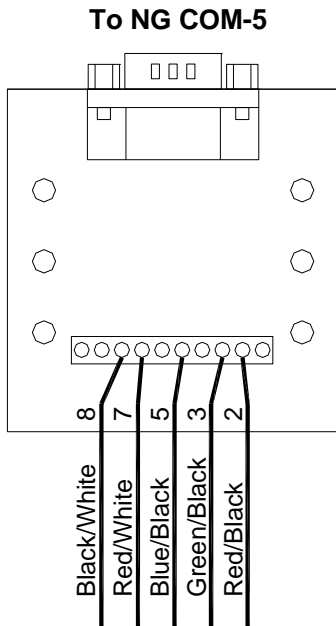



## 6.0 Preparation

---

The preparation phase starts with selecting the site. It ends with identifying the installation tools. Care taken during this phase can result in reduced maintenance and improved performance of the SmartScanNG<sup>2</sup> system.

This section covers what needs to be done before installation begins. Contained herein is time-tested advice that is well worth following. Also covered is how to install the wayside enclosure (aka bungalow) and, for those using AEI equipment, antenna masts.

### 6.1 Selecting a Site

Locate the site:

- On level, well-drained ground (avoid low areas where flooding may occur)
- In an area that doesn't normally require heavy braking by passing trains
- At least 300 feet (91.4 meters) from the nearest road crossing
- Away from a track joint, a track switch, and a side track
- By a track that is on gauge (avoid placing track hardware in curves)
- By a roadbed that is tamped, stable, and well maintained
- Where trains usually travel at more than 10 mph (16 kph)

### 6.2 Preparing the Scanner Location

To ready the scanner location:

- 1 Select a location to install the bearing scanners.
- 2 Inspect the ties (aka sleepers) and tie plates (aka sleeper plates) in the area where the scanners are to be installed.
- 3 If the ties or tie plates aren't in good condition, fix this problem before proceeding.
- 4 If the ties aren't well tamped, fix this problem before proceeding.
- 5 Measure the distance between the ties.  
The scanners should be centered in the crib of two ties spaced at least 14 inches (35.6 centimeters) apart.
- 6 If the ties aren't spaced at least 14 inches (35.6 centimeters) apart, fix this problem before proceeding.

7 Mark the rail at the midpoint between the ties.

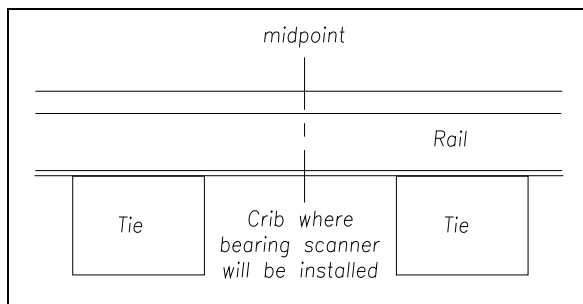

If you are going to install antenna masts, in addition to identifying where the bearing scanners will be installed, this midpoint mark will also be used later to locate where the holes for the mast bases are to be dug.

8 If your installation has wheel scanners:

a Select a location to install them.

The wheel scanners should be centered in the crib of the two ties immediately ahead (and to the north or east) of the bearing scanners.

b Repeat steps 2 through 6.

### 6.3 Preparing the AEI Antenna Masts

If your **single-track site** uses AEI equipment, to ready the masts (aka poles):

1 Using the dimensions below, dig two holes and add ballast.

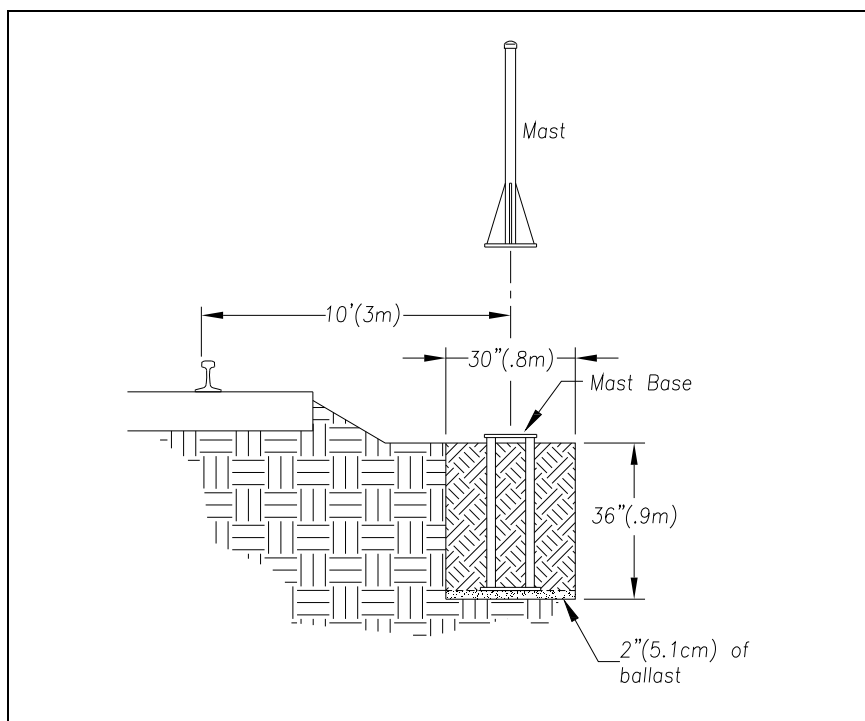

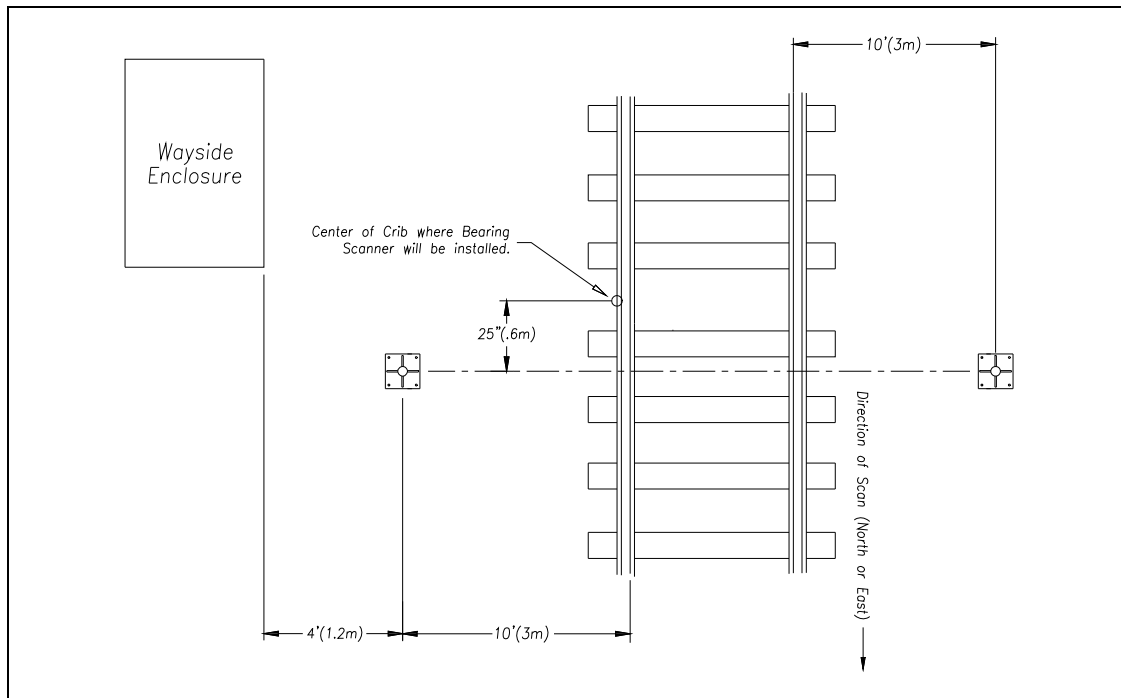

- 2 Lower one metal mast base into each hole, rotating it until one edge of the base is parallel to the track.

Install each base so that it's plumb and so that its center is 10 feet (3 meters) from the gauge side of the closest rail and 25 inches (0.6 meters) from the center of the crib in which the bearing scanner will be installed. Both bases will be north or east of the crib.

- 3 With the supplied hardware, attach one mast to each base.
- 4 Plumb each mast.
- 5 Ground each mast.

**When done, each mast should be level, grounded, attached to a base, and placed directly opposite the other mast.**

## 6.4 Preparing the Wayside Enclosure

To ready the wayside enclosure:

- 1 Place the wayside enclosure on level, well-drained ground.  
Face the door side (of the wayside enclosure) toward the tracks.
- 2 Level the wayside enclosure.

- 3 As a minimum, install two ground rods at opposite corners of the wayside enclosure.  
Ground rods should be at least 5/8-inch (1.59-centimeter) diameter copper-clad steel rods or 1-inch (2.5-centimeter) diameter zinc-coated steel rods. The minimum length of a ground rod is 8 feet (2.4 meters). Ground rods should be driven vertically for their full length, and the top of the ground rod should be located a minimum of 12 inches (30.5 centimeters) below the top of the subgrade at the toe of the ballast slope. The maximum allowable resistance of grounded rail or structures is 25 ohms.

**NOTE:**

**Canadian Pacific and some other railroads specify the use of four 5/8-inch diameter copper-clad rods, one on each corner of the wayside enclosure.**

Ground connectors, with attached copper wire, are welded to the underside of most wayside enclosures.

- 4 Attach one end of the copper wire that is attached to the wayside enclosure to the ground rod.

Telephone or Ethernet service is needed for you to access the system remotely.

- 5 If your site is not going to have telephone service, go to step 8.

- 6 Supply the site with normal telephone service.

- 7 Complying with all applicable codes and inspections, bring the telephone line into the wayside enclosure and leave it coiled on the floor.

In a later section, this telephone line will be wired to a surge protector in the SmartScanNG<sup>2</sup> enclosure.

- 8 Supply the site with a stable AC power source of at least 110-volts at 15-amperes.

**This manual only covers AC powered systems. If your site is going to use a DC power source, contact STC for help in doing so.**

- 9 Complying with all applicable codes and inspections, bring the outside **AC power line** to the circuit-breaker box inside the wayside enclosure.

The next step will remove power from the circuit-breaker box to the rest of the wayside enclosure.

- 10 Toggle off all breakers in the circuit-breaker box.

- 11 Complying with all applicable codes and inspections, wire the power line to the circuit-breaker box.

You can also wire the power line to a surge protector and then to the circuit-breaker box.

- 12 If not done already, wire from the circuit-breaker box to a grounded outlet.

In a later section, the SmartScanNG<sup>2</sup> enclosure and the battery charger will be plugged into this outlet. Don't plug it in now.

## 6.5 Receiving Your System

All the dragging-equipment detectors that a site needs are shipped on one pallet. All the components that make up one or more SmartScanNG<sup>2</sup> systems are shipped either in a crate or in a wayside enclosure, if one was ordered. The contents of this crate or wayside enclosure are specific to the site and are detailed on the packing list.

When the packages arrive at the site, check them immediately for exterior damage. If there is any, notify STC.

## 6.6 Returning Damaged or Defective Hardware

Return any damaged or defective hardware to STC for repair or replacement. You don't need a return authorization number. You don't need to call first. Just ship it directly to:

Southern Technologies Corporation  
Repair Department  
6145 Preservation Drive  
Chattanooga, Tennessee 37416-3638  
USA

With the returned hardware, include:

- Complete address of where the hardware is to be returned.
- Name and telephone number of the person who should be contacted to answer questions about the hardware.
- Written explanation of the hardware damage or defect.

## 6.7 Getting Help with the Installation

If a part is missing or if you have any problems installing a part, telephone STC's engineering staff. Except on major holidays, you can reach them at 423-892-3029, Monday through Friday, from 8:00 a.m. until 5:00 p.m. Eastern time. After business hours, calls are answered by machine. These calls are returned promptly the next business day.

When calling, state that you are calling about a SmartScanNG<sup>2</sup> system. Your call will then be directed to the appropriate person.

Though slower and more cumbersome, solving your problems by email is also possible.

## 6.8 Identifying the Installation Tools

Besides the tools needed to install signal cases, underground cables, and power services, you need these to install your SmartScanNG<sup>2</sup> system.

- Laptop computer
- Track drill with 3/8-inch bit
- 1/2-inch drive socket with 9/16-inch deep well socket
- 3/4-inch drive socket with 1-7/16-inch socket
- 9/16-inch torque wrench
- Medium size adjustable box wrench
- Carpenters level
- 1/2-inch nutdriver
- 11/32-inch nutdriver
- #2 Phillips head screwdriver
- Small slotted screwdriver (aka flathead screwdriver)
- 50-foot (15-meter) or longer tape measure
- Multimeter, reading at least 110 to 120 VAC, 0 to 50 VDC, and 0 to 1 megohm

In the box containing the bearing scanners are these tools.

- Short-handle 1-1/2-inch open-end wrench, which is used to install the scanner mounts and the deflectors
- T-handle 3/16-inch hex-wrench, which is used to install the flex-conduit-adaptor plates on the scanner mounts
- T-handle 1/4-inch hex-wrench, which is used to install the scanners on the scanner mounts
- Two combination 9/16-inch open-end box wrenches, which are used to install the transducers and align the scanners

When you finish using the supplied tools, store them in the wayside enclosure, if possible. They are also used to maintain the system.

## 7.0 Installing Wayside Enclosure Components

---

This section tells how to do the final installation of the wayside enclosure components.

### 7.1 Grounding System

The SmartScanNG<sup>2</sup> system is equipped with components for surge and lightning protection of the equipment attached to it. However, if the attachment to the earth grounding system isn't made correctly, the surge protection equipment may not work as designed, resulting in damaged or destroyed system components.

Ground rods should be at least 5/8-inch (1.59-centimeter) diameter copper-clad steel rods or 1-inch (2.5-centimeter) diameter zinc-coated steel rods. The minimum length of a ground rod is 8 feet (2.4 meters). Ground rods should be driven vertically for their full length, and the top of the ground rod should be located a minimum of 12 inches (30.5 centimeters) below the top of the subgrade at the toe of the ballast slope. The maximum allowable resistance of grounded rail or structures is 25 ohms.

As a minimum, **two driven ground rods** should be installed at opposite corners of the wayside enclosure (aka bungalow) in which the SmartScanNG<sup>2</sup> enclosure is installed. **A third driven ground rod** should be installed at the power pole to which the AC power connection is made. All three ground rods should be interconnected and exothermically bonded with a 6-AWG bare stranded copper wire. Two 6-AWG copper transitions welded to the skin of the wayside enclosure should be exothermically bonded to the driven grounds at its corners.

**NOTE:**

**Canadian Pacific and some other railroads specify the use of four 5/8-inch diameter copper-clad rods, one on each corner of the wayside enclosure.**

An exothermically bonded pigtail should be run through the floor of the wayside enclosure and terminated at a properly installed **ground bus** inside the wayside enclosure. There should be one ground bus per wayside enclosure.

### 7.2 SmartScanNG<sup>2</sup> Enclosure

There is one SmartScanNG<sup>2</sup> enclosure per track. At double-track sites, the leftmost SmartScanNG<sup>2</sup> enclosure supports track1 and the rightmost one supports track2.

The SmartScanNG<sup>2</sup> enclosure has four symmetrically placed 5/16-inch (7.9-millimeter) holes on the outside of the enclosure. Using these holes, four 1/4-inch x 1-inch lag screws, and four 1/4-inch flat washers, the enclosure can be mounted to any flat wooden surface. A 3/4-inch (1.9-centimeter) or thicker plywood works well. Other flat wooden surfaces may work just as well.

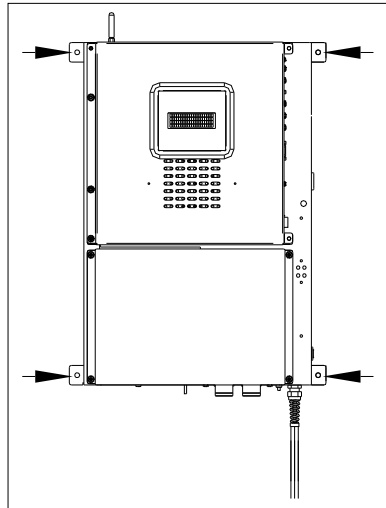

Mount the SmartScanNG<sup>2</sup> enclosure about 4 feet (1.2 meters) above the floor. Doing so positions the enclosure at a convenient height for installation and servicing. Mounting it at this height also allows you to install the power subsystem below it.

Mount the SmartScanNG<sup>2</sup> enclosure within 4 feet (1.2 meters) of a grounded three-wire 110 to 120-VAC outlet. The enclosure is provided with a 5-foot (1.5-meter) power cord. Be sure that the enclosure is level with the speaker on the top and the scanner connectors on the bottom.

To ground the SmartScanNG<sup>2</sup> enclosure:

- 1 Be sure that you have on hand an 11/32-inch nutdriver, a #2 Phillips head screwdriver, and a midsize slotted screwdriver.
- 2 Remove all power to the system.
- 3 Using a #2 Phillips head screwdriver and an 11/32-inch nutdriver, remove the two screws and four nuts securing the panel's cover to the rest of the SmartScanNG<sup>2</sup> enclosure.

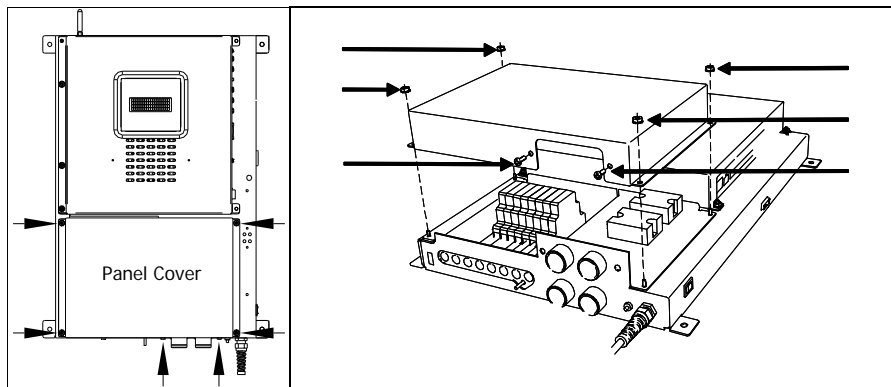



- 4 Separate the panel's cover from the SmartScanNG<sup>2</sup> enclosure.
- 5 Store the cover, screws, and nuts in a safe place until you replace them.
- 6 Attach one end of a 6-AWG stranded copper wire to the **ground bus** and the other end to the copper **ground lug** on the bottom right of the surge-suppression panel (in the SmartScanNG<sup>2</sup> enclosure).

### 7.3 Battery Charger

The NRS ELC-12/20-D battery charger has four symmetrically placed 5/16-inch (7.9-millimeter) holes on the outside of the enclosure. Using these holes, four 1/4-inch x 1-inch lag screws, and four 1/4-inch flat washers, the enclosure can be mounted to any flat wooden surface. A 3/4-inch (1.9-centimeter) or thicker plywood works well. Other flat wooden surfaces may work just as well.

Normally the battery charger is mounted about 1 foot (30 centimeters) above the floor and within 2 feet (61 centimeters) of the bottom of the SmartScanNG<sup>2</sup> enclosure. If this is inconvenient for you, mount it at any height between 1 foot (30 centimeters) and 4 feet (1.2 meters) above the floor and within 2 feet (61 centimeters) of the SmartScanNG<sup>2</sup> enclosure.

Be sure that the charger is level.

The figure below shows the front of a NRS ELC-12/20-D battery charger.

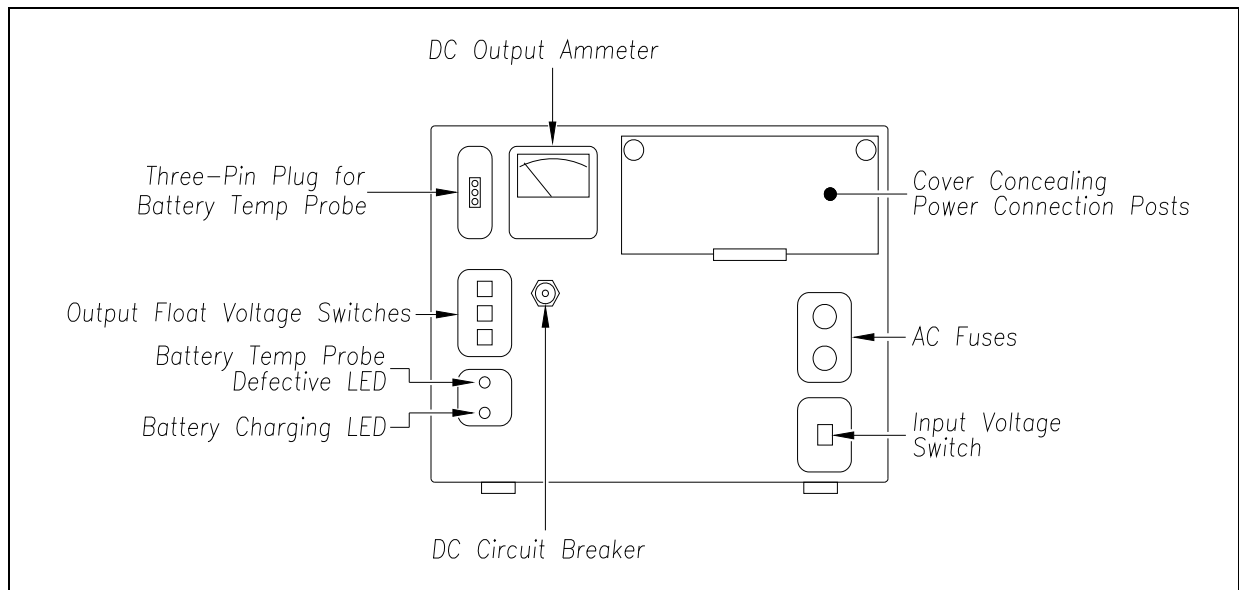

The input voltage switch can be set to 115 VAC or 230 VAC. Use 115 for input voltages between 108 and 128. Use 230 for input voltages between 216 and 256.

### To ground the battery charger:

- 1 Be sure that you have on hand a midsize slotted screwdriver.
- 2 Remove all power to the system.
- 3 Open the small door on the front of the charger by pulling out the push tabs.

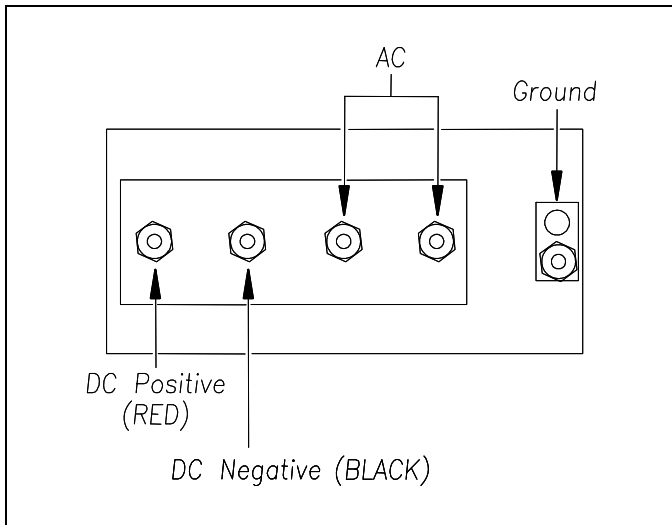

- 4 Attach one end of a 6-AWG stranded copper wire to the **ground bus** and the other end to the copper **ground lug** on the right of the power connection posts.

### To attach the power cord to the battery charger:

- 1 Be sure that you have on hand a wire stripper, a pliers-type crimping tool, a 1/2-inch nutdriver, and a midsize slotted screwdriver.
- 2 Remove all power to the system.  
Be sure that the power cord isn't plugged into an outlet or in any other way attached to a power source.
- 3 Using a wire stripper, remove 1/4 inch (6.4 millimeters) of insulation from the ends of the three wires coming from the supplied power cord.
- 4 Connect the green wire to the copper ground lug to the right of the power connection posts.  
The green wire shares the ground lug with the wire from the ground bus.
- 5 Using a pliers-type crimping tool, crimp a ring terminal to the end of the white wire and another ring terminal to the end of the black wire.
- 6 Using a 1/2-inch nutdriver, connect these ring terminals to the two rightmost binding posts, as marked on the panel behind the posts.  
Two 320-volt varistors (round disks with ring terminals) were shipped with the charger.
- 7 Using a 1/2-inch nutdriver, connect one 320-volt varistor to the binding posts to which you just connected the white and black wires.
- 8 At this time, do not plug the just-wired power cord into an outlet or other power source.

## 7.4 Fuse Block

There is one fuse block per SmartScanNG<sup>2</sup> enclosure. To mount the fuse block and wire it to the SmartScanNG<sup>2</sup> enclosure:

- 1 Be sure that you have on hand a wire cutter, a wire stripper, a pliers-type crimping tool, and a midsize slotted screwdriver.
- 2 Remove all power to the SmartScanNG<sup>2</sup> enclosure. Remove the fuse from the fuse block and store it in a safe place until you replace it (next section).

Using the supplied screws, mount the fuse block and the distribution block near the SmartScanNG<sup>2</sup> enclosure. Be sure that there is enough room above and below the block to make all connections.

STC supplies each system with 15 feet (4.6 meters) of red-black 10-AWG 2-conductor zip wire. It may not be necessary to use all 15 feet (4.6 meters) of this zip wire. You should cut it to the appropriate length for your configuration.

- 3 Wire fuse block per figure below. Connect to surge suppression panel of the SmartScanNG<sup>2</sup> enclosure (red & black terminal blocks on the right side of DIN rail).

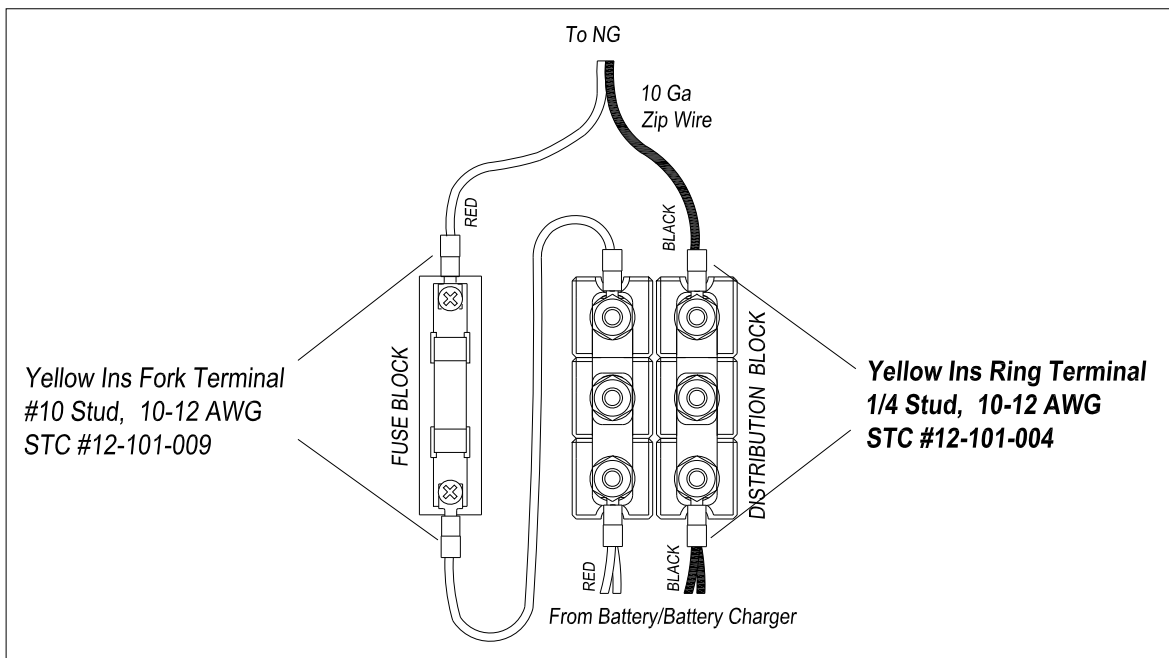

- 4 If this is a multi-track site, repeat steps 2 through 3 on the other systems.

## 7.5 Power Subsystem

The figure below shows the major parts of the power subsystem powered from an AC power source at a **single-track site**.

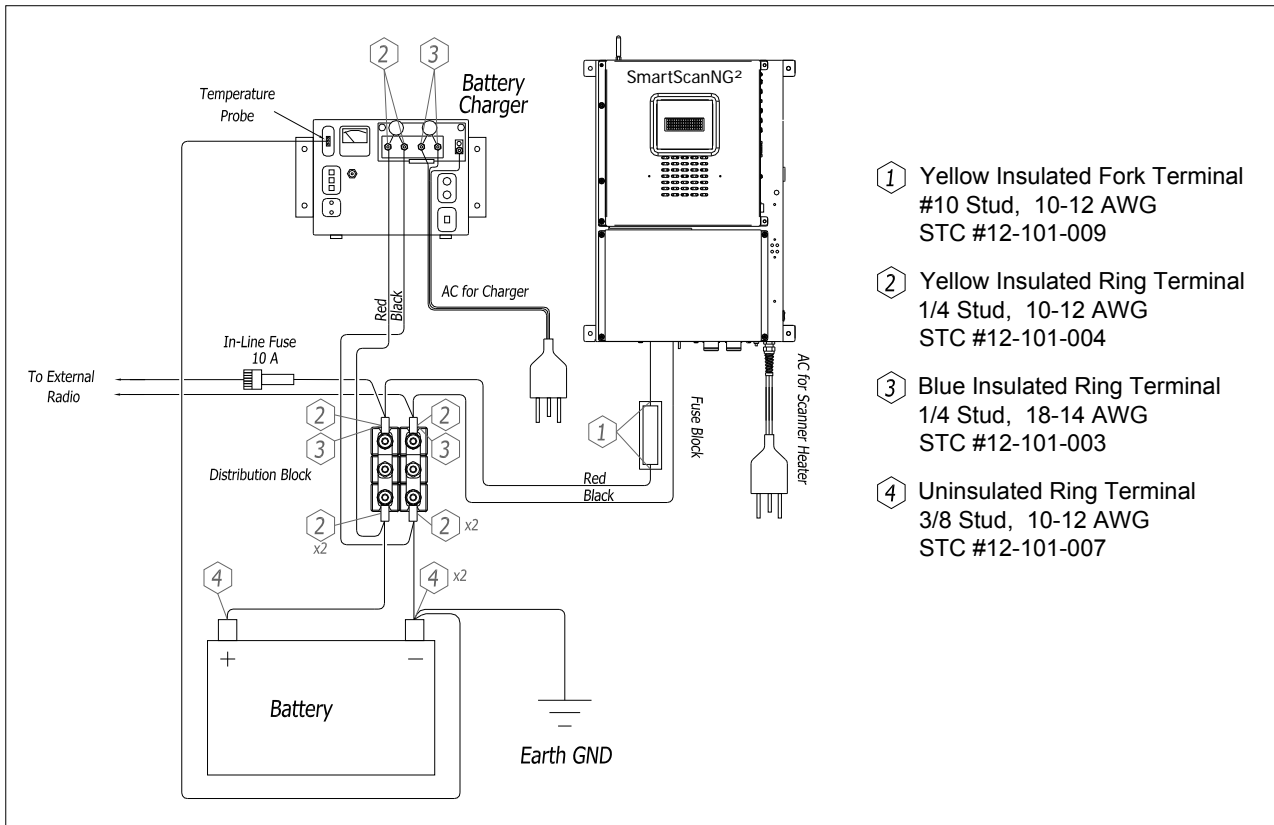

To finish installing the power subsystem:

- 1 Be sure that you have on hand a wire cutter, a wire stripper, a pliers-type crimping tool, a 1/2-inch nutdriver, and a midsize slotted screwdriver.
- 2 Remove all power to the system.  
Be sure that the SmartScanNG<sup>2</sup> enclosure and the battery charger aren't plugged into an outlet or in any other way attached to a power source.
- 3 Complete all system wiring per figure above.
- 4 The fuse block isn't wired directly to either the battery or the battery charger. It is wired directly to the distribution block. The distribution block contains six nuts. Loosening the middle gold nuts disconnects the incoming DC power and the rest of the system.
- 5 If tight, loosen the middle gold nuts on the distribution block.

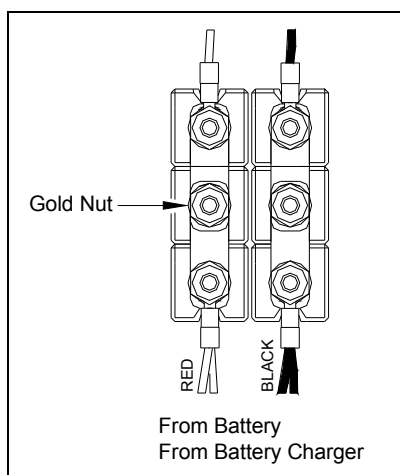

- 6 Using a 1/2-inch nutdriver, connect the ring terminal ends to the top of the distribution block.
- 7 Cut the red-black 10-AWG 2-conductor zip wire to fit **between the battery charger and the bottom edge of the distribution block.**
- 8 Strip 1/4 inches (6.4 millimeters) of insulation from both ends of both conductors. Crimp one ring terminal to the end of each of these four conductors.
- 9 Using a 1/2-inch nutdriver, connect one ring terminal on the red conductor and one on the black conductor to the two leftmost binding posts (of the battery charger), as marked on the panel behind the posts.

Be sure that the red conductor (positive) is attached to the leftmost binding post and the black conductor (negative) to the right of it.

Two 320-volt varistors (round disks with ring terminals) were shipped with the charger.

- 10 Using a 1/2-inch nutdriver, connect one 320-volt varistor to the binding posts to which you just connected the red and black wires.
- 11 Cut the red-black 10-AWG 2-conductor zip wire to fit **between the battery and the bottom edge of the distribution block.**
- 12 Strip 1/4 inches (6.4 millimeters) of insulation from both ends of both conductors. Crimp one ring terminal to the end of each of these four conductors.

## WARNING

Wear appropriate eye and skin protection when servicing batteries.

- 13 Using a 1/2-inch nutdriver, connect the battery temperature probe (from the battery charger) to the negative battery post.
- 14 Plug the other end of the battery temperature probe into the receptacle labeled **Temp Probe** on the front of the charger.
- 15 Using a 1/2-inch nutdriver, connect the red wires from the battery charger and from the positive battery post to the left side of the bottom edge of the distribution block.
- 16 Using a 1/2-inch nutdriver, connect the black wires from the battery charger and from the negative battery post to the right side of the bottom edge of the distribution block.

## WARNING

Once the battery is installed, touching any right-sided terminal and any left-sided terminal on the distribution block simultaneously with a metal object will short the battery.

17 If this is a single-track site, go to next section..

If this is a double-track site, repeat steps 1 through 16 on the second track.

## 7.6 Bearing Scanners

There are two bearing scanners per track. At double-track sites, the cables from the bearing scanners on track1 are connected to the bottom of the leftmost SmartScanNG<sup>2</sup> enclosure. The cables from track2 are connected to the bottom of the rightmost SmartScanNG<sup>2</sup> enclosure.

To connect the bearing scanners to the SmartScanNG<sup>2</sup> enclosure:

1 Be sure that both bearing scanners are installed on the track.

At a single-track site, the cable from the bearing scanner on rail1 should be labeled **RAIL1**. The cable from the bearing scanner on rail2 should be labeled **RAIL2**. If the track runs north and south, RAIL1 is the east rail and RAIL2 is the west rail. If the track runs east and west, RAIL1 is the north rail and RAIL2 is the south rail.

At a double-track site, they're labeled **RAIL1-TRACK1**, **RAIL2-TRACK1**, **RAIL1-TRACK2**, or **RAIL2-TRACK2**, whichever is appropriate.

2 Plug the connector from the bearing scanner on rail1 (that is, from the north or east rail) into the rightmost box connector on the backmost part of the bottom of the SmartScanNG<sup>2</sup> enclosure.

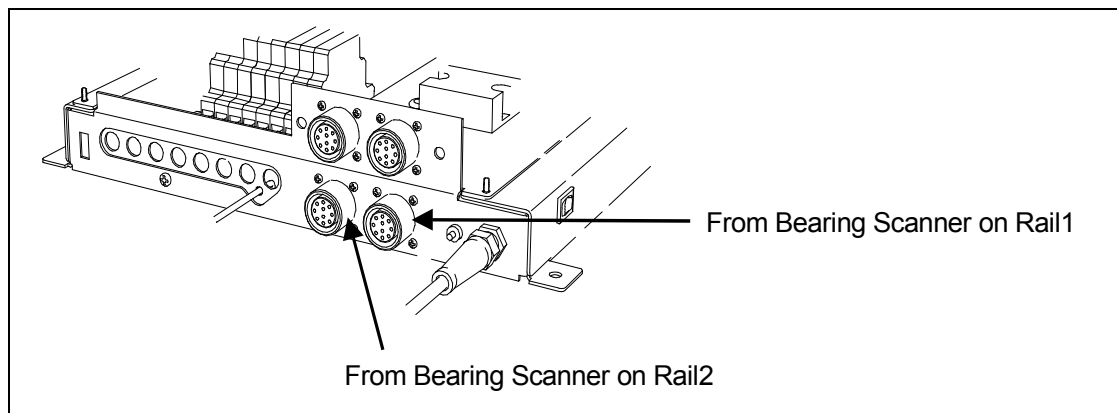

3 Plug the connector from the bearing scanner on rail2 (that is, from the south or west rail) into the leftmost box connector on the backmost part of the bottom of the SmartScanNG<sup>2</sup> enclosure.

4 If this is a double-track site, repeat steps 1 through 3 on the second track.

## 7.7 Wheel Scanners

Not all sites use wheel scanners. If your site doesn't use them, skip to the next section.

If your site uses them, there are two wheel scanners per track. At double-track sites, the cables from the wheel scanners on track1 are connected to the bottom of the leftmost SmartScanNG<sup>2</sup> enclosure. The cables from track2 are connected to the bottom of the rightmost SmartScanNG<sup>2</sup> enclosure.

To connect the wheel scanners to the SmartScanNG<sup>2</sup> enclosure:

- 1 Be sure that both wheel scanners are installed on the track.

At a single-track site, the cable from the wheel scanner on rail1 should be labeled **W-RAIL1**. The cable from the wheel scanner on rail2 should be labeled **W-RAIL2**. If the track runs north and south, RAIL1 is the east rail and RAIL2 is the west rail. If the track runs east and west, RAIL1 is the north rail and RAIL2 is the south rail.

At a double-track site, they're labeled **W-RAIL1-TRACK1**, **W-RAIL2-TRACK1**, **W-RAIL1-TRACK2**, or **W-RAIL2-TRACK2**, whichever is appropriate.

- 2 Plug the connector from the wheel scanner on rail1 (that is, from the north or east rail) into the rightmost box connector on the frontmost part of the bottom of the SmartScanNG<sup>2</sup> enclosure.

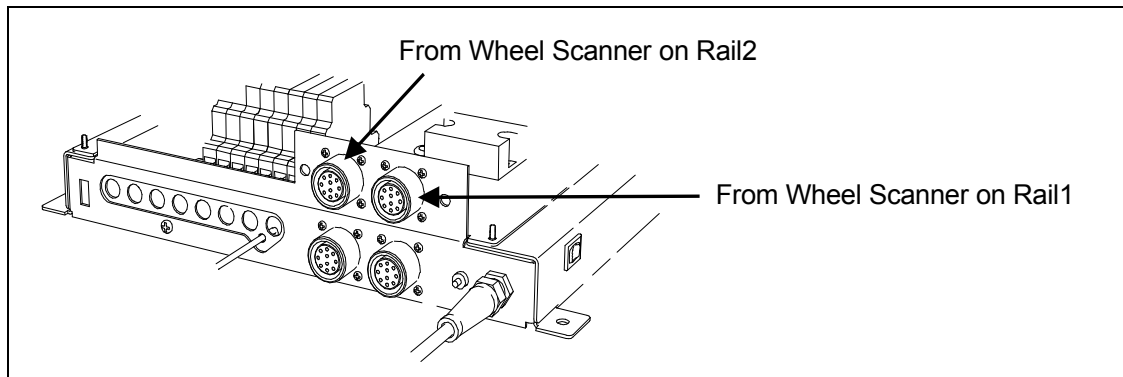

- 3 Plug the connector from the wheel scanner on rail2 (that is, from the south or west rail) into the leftmost box connector on the frontmost part of the bottom of the SmartScanNG<sup>2</sup> enclosure.
- 4 If this is a double-track site, Repeat steps 1 through 3 on the second track. The cables from track2 are connected to the rightmost SmartScanNG<sup>2</sup> enclosure.

## 7.8 Gating Transducers

There are two gating transducers per track, each having two wires. One black wire and one white wire. At a single-track site, the wires from gating transducer TO1 should be labeled **TO1**. The wires from gating transducer TO2 should be labeled **TO2**.

At a double-track site, they should be labeled **TO1-TRACK1**, **TO2-TRACK1**, **TO1-TRACK2**, or **TO2-TRACK2**, whichever is appropriate. At double-track sites, the wires from the gating transducers on track1 are connected inside the leftmost SmartScanNG<sup>2</sup> enclosure. The wires from track2 are connected inside the rightmost SmartScanNG<sup>2</sup> enclosure.

On each surge-suppression panel, there is one UTB (universal transient barrier) assigned to transducer **TO1** and another to transducer **TO2**. These UTBs protect the SmartScanNG<sup>2</sup> system from transients and surges, which can be induced onto external wiring by lightning. Each UTB has two rows of connectors. The wires from one gating transducer are terminated at the bottom row of connectors. The top row of connectors is wired at the factory to TS3 on the System-Interconnect board.

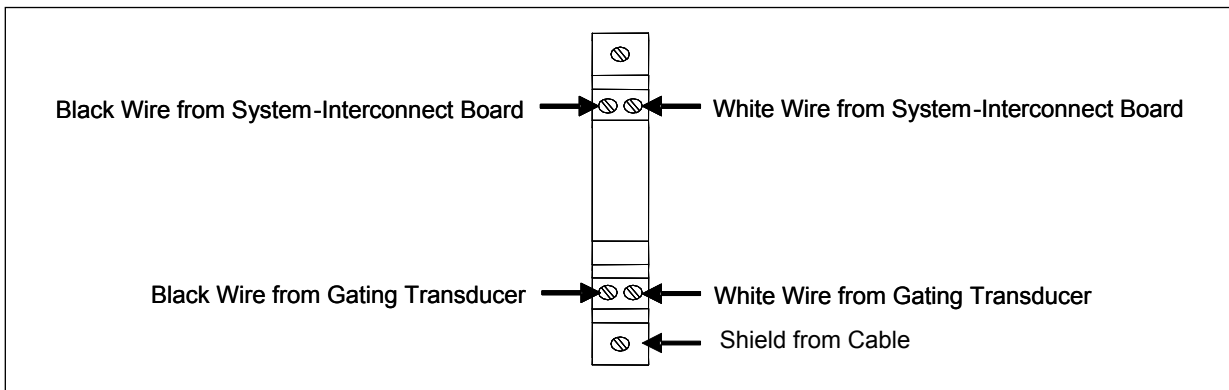

**Observe correct polarity** when you connect the wires from the transducers. The polarity is correct when the transducer's white wire is connected directly under the existing white wire at the top of the UTB, and the transducer's black wire is connected directly under the existing black wire at top of the UTB. Connect **TO1** first and **TO2** second. **TO2** is the northmost or eastmost gating transducer.

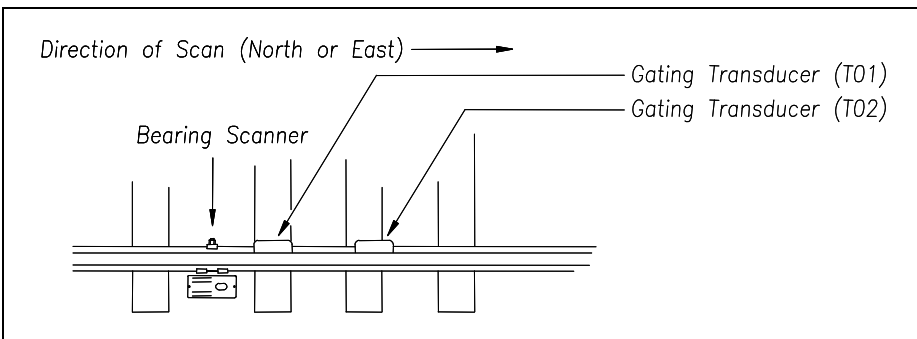



## 7.9 Advance Transducers

Not all systems use advance transducers. If yours doesn't, skip ahead to the next section.

There are two advance transducers per track, each having two wires. One black wire and one white wire. At a single-track site, the wires should be labeled **ADV1** and **ADV2**. At a double-track site, they should be labeled **ADV1-TRACK1**, **ADV2-TRACK1**, **ADV1-TRACK2**, or **ADV2-TRACK2**, whichever is appropriate. At double-track sites, the wires from the advance transducers on track1 are connected inside the leftmost SmartScanNG<sup>2</sup> enclosure. The wires from track2 are connected inside the rightmost SmartScanNG<sup>2</sup> enclosure.

On each surge-suppression panel, there is one UTB assigned to transducer **ADV1** and another to transducer **ADV2**. These UTBs protect the SmartScanNG<sup>2</sup> system from transients and surges, which can be induced onto external wiring by lightning. Each UTB has two rows of connectors. The wires from one advance transducer are terminated at the bottom row of connectors. The top row of connectors is wired at the factory to TS3 on the System-Interconnect board.

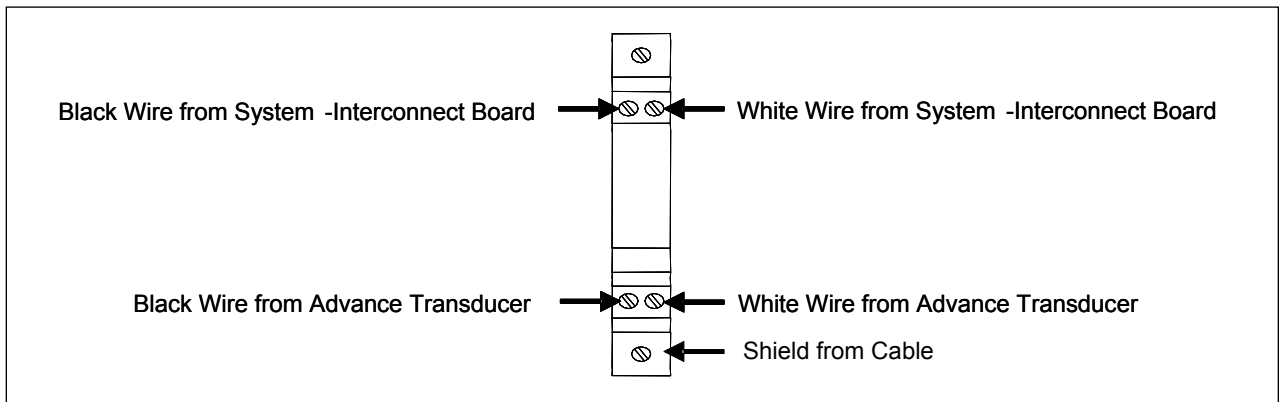

**Observe correct polarity** when you connect the wires from the transducers. The polarity is correct when the transducer's white wire is connected directly below the existing white wire at the top of the UTB, and the transducer's black wire is connected directly below the existing black wire at the top of the UTB. Connect **ADV1** first and **ADV2** second. **ADV1** is the advance transducer to the right of gating transducer **TO2**. **ADV2** is the one to the left of gating transducer **TO1**.

## 7.10 Dragging-Equipment Detector

Most, but not all, systems use dragging-equipment detectors. If your site doesn't use them, skip ahead to the next section.

When used, there is one dragging-equipment detector per track, each having two wires. Usually, one black wire and one white wire. The color of your wires may be different.

At double-track sites, the wires from the dragging-equipment detector on track1 are connected inside the leftmost SmartScanNG<sup>2</sup> enclosure. The wires from track2 are connected inside the rightmost SmartScanNG<sup>2</sup> enclosure.

On the DIN rail assembly, the UTB labeled **DED** is for the dragging-equipment detector. This UTB protects the SmartScanNG<sup>2</sup> system from transients and surges, which can be induced onto external wiring by lightning. The UTB has two rows of connectors. The wires from the dragging-equipment detector are terminated at the bottom row of connectors. The top row of connectors is wired at the factory to TS4 on the System-Interconnect board.

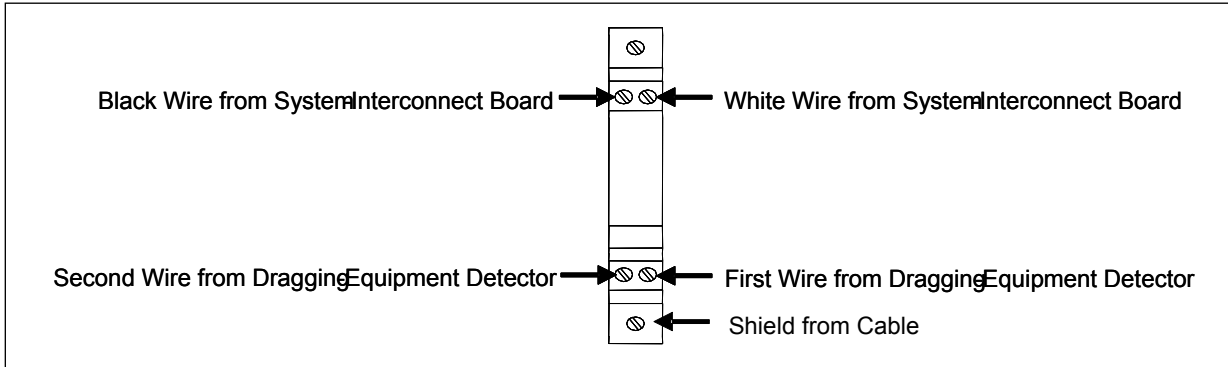

Correct polarity need not be observed when connecting the wires from the detector. One wire from the detector should be connected directly below the existing white wire at the top of the UTB, and the other wire should be connected directly below the existing black wire at the top of the UTB.

## 7.11 Telephone

Not all sites have telephone service. When present, there is one telephone line per site. If your site doesn't have telephone service, skip ahead to the next section.

The telephone service provider should terminate their drop on a lightning arrester terminal on the service pole. From the lightning arrester block, run a four-wire service cord to the wayside enclosure and route it to the DIN rail assembly on the surge-suppression panel (in the SmartScanNG<sup>2</sup> enclosure). At double-track sites, the service cord is routed to the DIN rail assembly in the leftmost SmartScanNG<sup>2</sup> enclosure.

On the DIN rail assembly, the UTB labeled **TELCO** is for the telephone line. This UTB protects the SmartScanNG<sup>2</sup> system from transients and surges, which can be induced onto external wiring by lightning. The UTB has two rows of connectors. The wires from the incoming telephone line are terminated at the bottom row of connectors. The top row is wired at the factory. The green wire of the incoming telephone line is terminated on the left. The red wire is terminated on the right. The other two telephone wires (yellow and black) aren't required for a SmartScanNG<sup>2</sup> system.

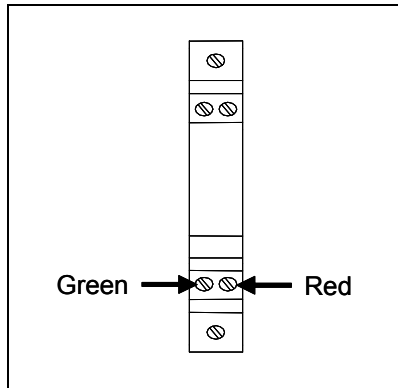

At double-track sites, the telephone line or an Ethernet connection can be connected to only one SmartScanNG<sup>2</sup> enclosure (usually the leftmost enclosure). System1 is the one with the telephone line or the Ethernet connection attached to the installed modem. To communicate remotely with another SmartScanNG<sup>2</sup> enclosure at the same site, you would start by using the **Enter Pass-Thru Mode option** on the Main menu of system1. At double-track sites, attach a crossover (null-modem) cable from **COM4 of system1** to **COM1 of system2**.

## 7.12 Shielded Temperature Probe

The temperature probe is encased in a radiation shield that shields it from direct sunlight and allows ambient air to flow through and around it. The probe mounts to the outside wall of the wayside enclosure and provides accurate temperature indications over a range of -45°C to +65°C (-49°F to +149°F). Site ambient temperature (when the train passed the site) is included with most system reports.

There is one shielded temperature probe per system. To install this probe:

- 1 Be sure that you have on hand the customer-supplied fasteners needed to attach the shielded temperature probe to the outside of the wayside enclosure; a wire stripper; and the fasteners needed to attach the RF-filter assembly to the inside of the wayside enclosure.
- 2 If you haven't done so already, remove the shielded temperature probe and the RF-filter assembly from its box.
- 3 Mount the probe onto the outside of the wayside enclosure.

The probe should be mounted on the side of the wayside enclosure furthest from the track. This should be the side of the enclosure where the SmartScanNG<sup>2</sup> enclosure is mounted. No matter where it is mounted, make sure the entire shielded temperature probe is in the top third of the enclosure or above the roof of the enclosure.

- 4 Route the cable from the probe to the bottom of the SmartScanNG<sup>2</sup> enclosure that it is associated with.

In sheet metal, use a rubber grommet in every hole through which you route the cable.

- 5 As shown below, insert the four Molex pins (on the end of the cable of the probe) into the supplied Molex housing.

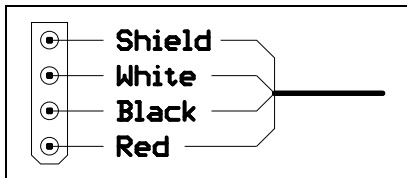

The red wire supplies 12 VDC to the shielded temperature probe.

- 6 Mate the Molex housing (on the end of the cable of the probe) to the factory-wired Molex socket on the end of the RF-filter assembly.

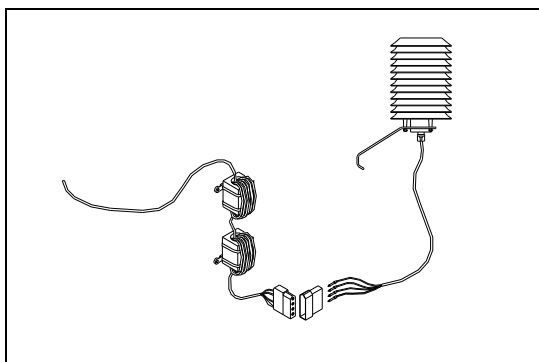

- 7 Using a wire stripper, remove 1/4 inches (6.4 millimeters) of insulation from the ends of the four wires coming from the other end of the RF-filter assembly.

On the DIN rail assembly, the two UTBs labeled **TempProbe** are for the shielded temperature probe. Each UTB has four rows of connectors. As shown below, the wires from the shielded temperature probe are terminated at the bottom row of connectors. The top connectors on these UTBs are prewired at the factory and need no further wiring.

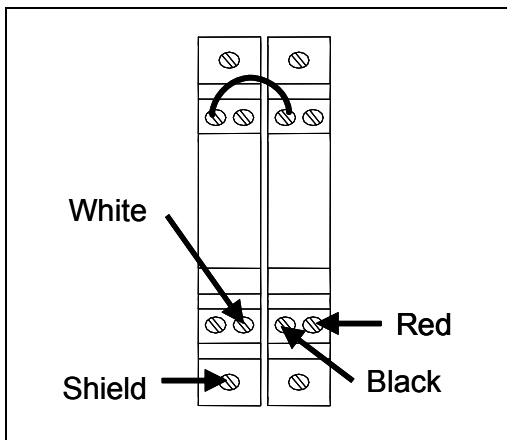

- 8 As shown above, terminate the wires from the end of the RF-filter assembly.
- 9 Mount the two filters of the RF-filter assembly onto the inside of the wayside enclosure.

## 7.13 Radio Antenna

At double-track sites, there is usually one radio per track. This is the case when internal radios are used, but not always the case when external radios are used. When external radios are used, the components supporting track2 don't need to have their own radio. Instead, they can use the radio that supports track1. Using only one radio at a double-track site isn't covered in this guide. Call STC for help in doing this.

For the radio to function properly, it needs an antenna. However, STC doesn't supply the antenna or the hardware to install it.

When installing your antenna, follow the directions that came with your antenna and:

- 1 Mount the antenna onto the outside of the wayside enclosure, preferably on the roof of the enclosure.  
If you mount it on the side of the enclosure, make sure the whole antenna is above roofline.
- 2 Route the coaxial cable from the antenna mounting base to the SmartScanNG<sup>2</sup> enclosure.  
In sheet metal, use a rubber grommet in every hole through which you route the cable.
- 3 If needed, install a PL-259 UHF or a type-N plug onto the end of the cable.
- 4 Connect this plug to the type-N jack on the top of the SmartScanNG<sup>2</sup> enclosure.  
The enclosure is equipped with a type-N jack. For those using a PL-259 UHF plug, a UHF-to-type-N adapter is shipped with the SmartScanNG<sup>2</sup> enclosure.
- 5 If this is a double-track site, repeat steps 1 through 4 for the radio in the other SmartScanNG<sup>2</sup> enclosure.

## 7.14 AEI Interface Module

Not all sites use an AEI Interface module. If your site doesn't use one, skip ahead to the next section.

Mount the AEI Interface module (2300-750) next to the SmartScanNG<sup>2</sup> enclosure. Under the AEI Interface module, mount two Joslyn surge protectors (aka Joslyn coaxial lightning arresters).

Attach the power cable from AEI Interface module to the top edge of the distribution block. Attach the serial communications cable (Dsub9F to Dsub9F null) to **COM5** of the Controller module (2300-602).

Attach the coaxial cables, coming from the AEI antennas, to their respective Joslyn surge protectors (aka Joslyn coaxial lightning arresters). Attach the other end of the grounded surge protectors to the AEI Interface module (2300-750).

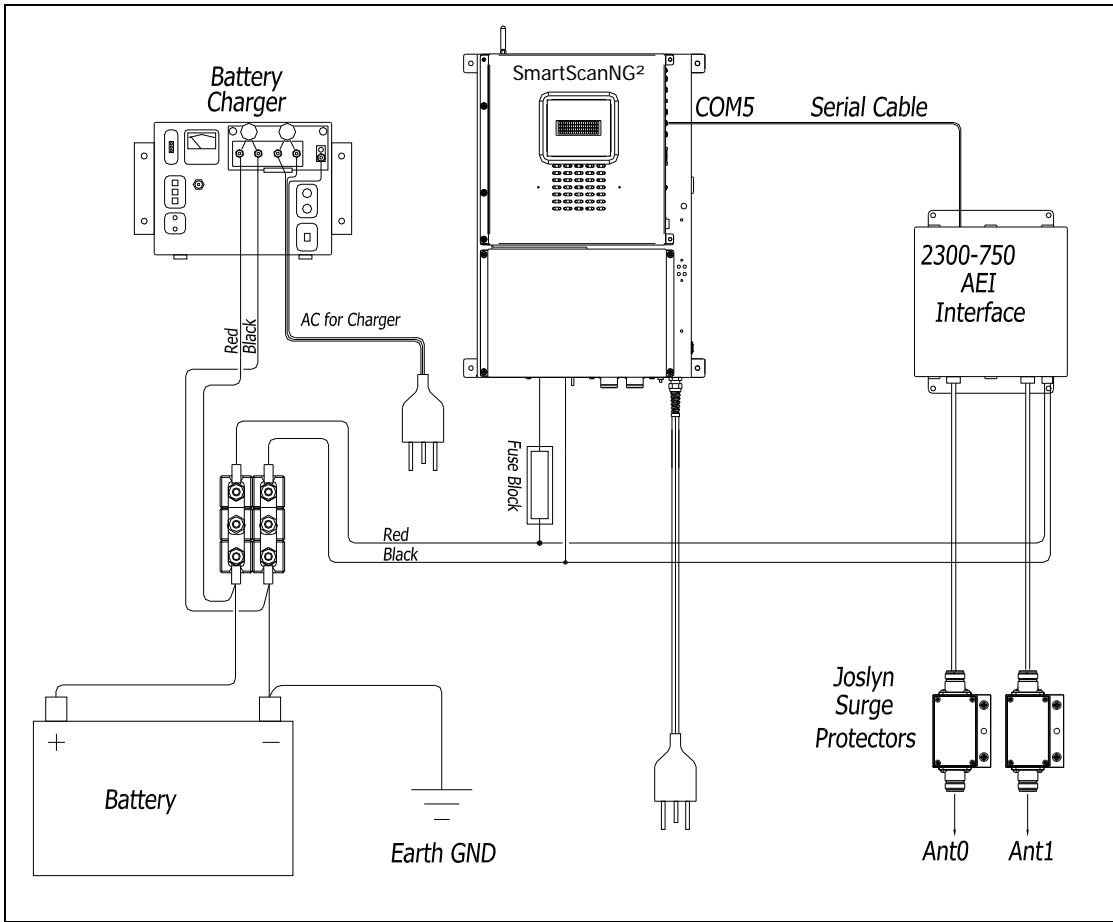

The AEI Interface module (2300-750) chassis should be tied to earth ground. To do this, connect a ground wire to the ground connector on the mounting tab on the AEI Interface module. Any size copper wire can be used for grounding. Instead of wrapping the wire around the ground connector, either crimp a ring terminal to the grounding wire before slipping it onto the ground connector or slip a copper ground lug onto the ground connector and use it to hold the grounding wire.

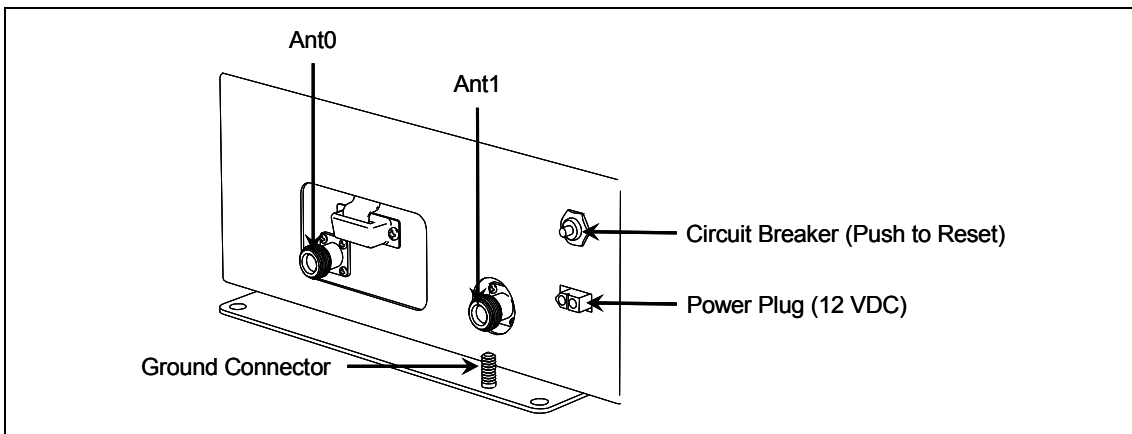

## 7.15 High-Load/High-Wide Detector

Some systems use high-load detectors. Others use high-wide detectors. If your site doesn't use either of them, skip the instructions below and go to the next section.

When used, there is one high-load/high-wide detector per track, each having two wires.

At double-track sites, the wires from the high-load/high-wide detector on track1 are connected inside the leftmost SmartScanNG<sup>2</sup> enclosure. The wires from track2 are connected inside the rightmost SmartScanNG<sup>2</sup> enclosure.

On the DIN rail assembly, the UTB labeled **HIGH** is either for the high-wide detector or the high-load detector. This UTB protects the SmartScanNG<sup>2</sup> system from transients and surges, which can be induced onto external wiring by lightning. The UTB has two rows of connectors. The wires from the high-load/high-wide detector are terminated at the bottom row of connectors. The top row is wired at the factory to TS4 on the System-Interconnect board.

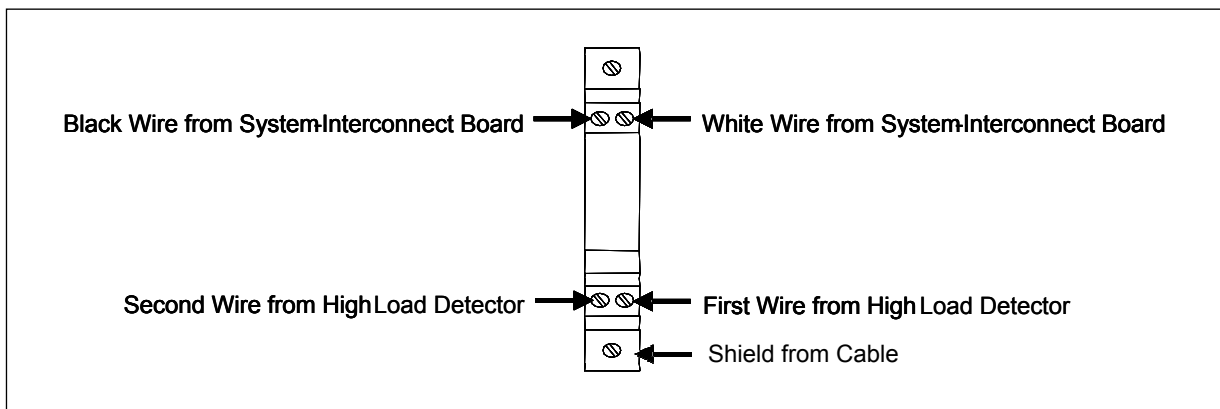

Correct polarity need not be observed when connecting the wires from the high-load/high-wide detector. One wire from the detector should be connected directly below the existing white wire at row two of the UTB, and the other wire should be connected directly below the existing black wire at row two of the UTB.

**To designate High-Load alarms**, YES must appear after the words High Load on the Equipment menu and Separate must appear after the words Clearance Mode on the Equipment menu. **To designate High-Wide alarms**, YES must appear after the words High Load on the Equipment menu and Multiplexed must appear after the words Clearance Mode on the on the Equipment menu.





## 8.0 Placing a System into Service

---

This section describes all the things that need to be done before placing a SmartScanNG<sup>2</sup> system into service.

### 8.1 Checking the Trackside Components

To check the correctness of the installation of the trackside components:

- 1 Be sure that you have on hand a tape measure, a #2 Phillips head screwdriver, a small slotted screwdriver, a 9/16-inch torque wrench, a laptop computer, a multimeter, and the alignment fixture.
- 2 At trackside, check track conditions on all tracks. If any track is pumping (vertical displacement of the rails) or running (lateral displacement of the rails) more than 2 inches (5 centimeters), have it repaired before proceeding.
- 3 Before proceeding, check that all the track-mounted hardware has been installed properly.
- 4 At trackside, check all transducer-mounting bolts on all tracks to make sure that all transducers are snug against the rail.

Four bolts are needed to hold the transducer in place. Two square-head bolts go through the mounting plate and transducer body. Two hex-head bolts go through the mounting plate and rail. If any of these bolts are sheared or missing, they must be replaced with the correct replacement bolt. Also, if any washers or nuts are missing, they must be replaced.

Each installed transducer body should be 1-9/16 inches (3.97 centimeters) below the top of the rail and parallel to it. You can meet this requirement by using the transducer height bracket on the bottom of the alignment fixture.

- 5 Place the alignment fixture across both rails, centered over each transducer in turn.

- 6 Check if each transducer body just touches the bracket.

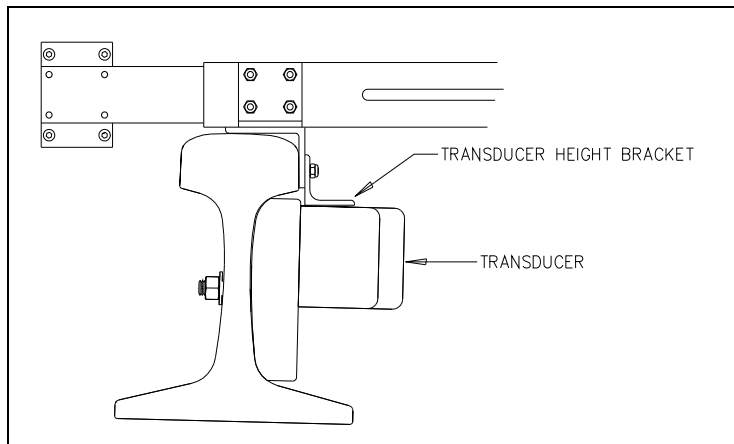

The fixture should be snug against the top and gauge of both rails. This may be impossible if the transducer body is less than 1-9/16 inches (3.97 centimeters) below the top of the rail or if the transducer body isn't parallel to the top of the rail.

- 7 If a transducer body doesn't just touch the bracket:
- Loosen the nuts holding the transducer body to its mounting plate.
  - By sliding it up and down, adjust the transducer body to the proper height.
  - Tighten each hex nut with a 9/16-inch torque wrench to a **torque of 12 to 15 foot-pounds (16.3 to 20.3 newton-meters)**.

**Don't exceed a torque of 15 foot-pounds (20.3 newton-meters). Doing so can weaken or break a bolt, requiring the bolt to be replaced.**

- 8 At the trackside, check all scanner-mounting bolts on all tracks.  
If you need to tighten a scanner's clamping nut or locking nut, **don't exceed a torque of 50 foot-pounds (67.8 newton-meters)**. **Doing so can cause failure of the mount.**
- 9 From under all scanners, remove ballast that could damage the scanners during train passage. Remove all obstructions to the scan path of each scanner.

## 8.2 Checking the Wayside Enclosure Components

To check the correctness of the installation of the wayside enclosure components:

- 1 If the radio antenna and the shielded temperature probe haven't been mounted to the outside of the wayside enclosure, mount them.

**Section 7.0 - Installing Wayside Enclosure Components** tells how to install the radio antenna and the shielded temperature probe.

- 2 If the wayside enclosure isn't attached to a properly installed outside grounding system, fix this problem before proceeding.

**Section 7.1- Grounding System** tells how to properly ground the SmartScanNG<sup>2</sup> system.

- 3 Check that all wayside enclosure components have been installed properly.
- 4 Inside the wayside enclosure, check that there are no loose wires or cables.

## 8.3 Powering-up the SmartScanNG<sup>2</sup> System

To power-up the SmartScanNG<sup>2</sup> system:

- 1 If plugged in, unplug the SmartScanNG<sup>2</sup> enclosure and the battery charger.

The NRS ELC-12/20-D battery charger doesn't have a power switch. To turn it off, you need to disconnect it from its power source. Even after AC and DC are disconnected, a voltage is still present on the DC terminals because of the energy stored in the capacitor.

The SmartScanNG<sup>2</sup> enclosure doesn't have an AC power switch and needs to be disconnected from its AC power source to stop AC from entering the enclosure. However, it does have a DC power switch.

- 2 If toggled on, toggle off the DC power switch on the right edge of the SmartScanNG<sup>2</sup> enclosure.

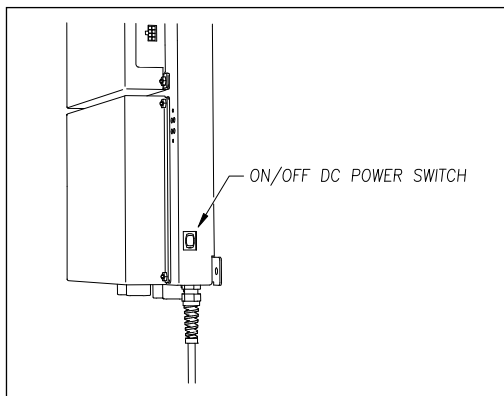

- 3 Toggle on the AC circuit breaker in the circuit-breaker box.

The next two steps assume your site uses 110-120 VAC. If your site uses 220-250 VAC, skip the next two steps. If your site uses any other AC voltage, skip all the steps below and call STC for help.

- 4 Before proceeding, ensure the AC power at all outlets is stable and at least 110 volts at 15 amperes. Confirm that the battery charger is properly grounded to the ground bus and its vents are not blocked.

There are vents on the top, bottom, and sides of the charger. Blocking any of these vents could result in damage to the charger or battery.

- 5 On the front of the unplugged battery charger:
  - a Check the setting of the input voltage switch on the bottom-right corner.

The input voltage switch can be set to 115 VAC or 230 VAC. Use 115 for input voltages between 108 and 128. Use 230 for input voltages between 216 and 256.

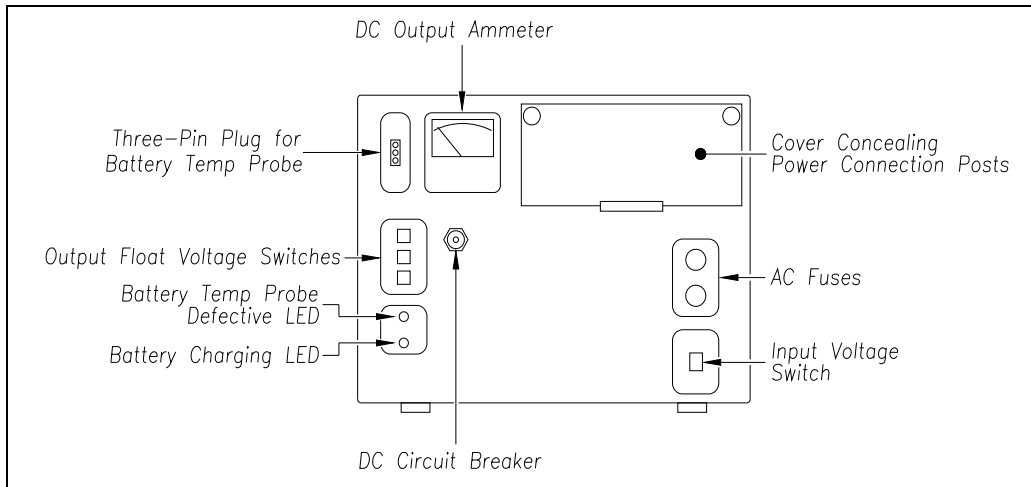

- b** Check the output float voltage switches on the center-left edge. Be sure each switch is set on a number and not between numbers.
- c** If the switches aren't set within the range 12.70 through 14.50 VDC, reset them to 14.00 VDC.

To reset the switches, use a small slotted screwdriver to turn each switch to the desired number. The ten's digit is always 1 and can't be changed. The top switch controls the unit's digit. The middle switch controls the tenth's digit. The bottom switch controls the hundredth's digit. The factory default is **14.00 VDC**, which is the **recommended setting**. To select 14.00 VDC, turn the top switch to 4, the middle switch to 0, and the bottom switch to 0.

- d** Open the small door cover on the top-right corner. Check that all binding posts nuts are tight and that all wiring is correct.
- e** If loose, tighten the middle gold nuts on the distribution block.

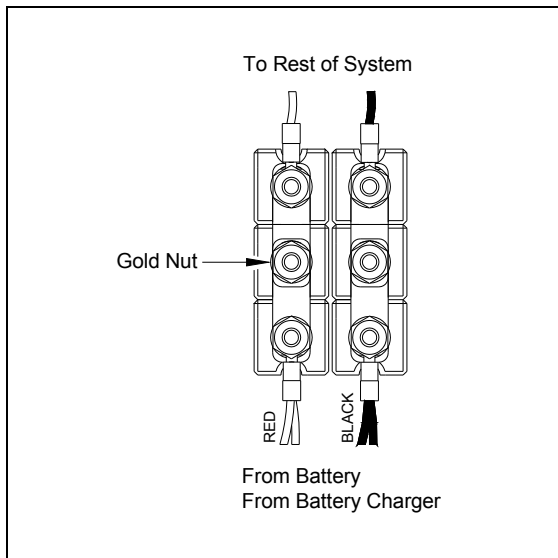

- 6** Plug in the SmartScanNG<sup>2</sup> enclosure and the battery charger.

## WARNING

Plugging the power cord at the bottom of the SmartScanNG<sup>2</sup> enclosure into an outlet of more than 128 volts will severely damage your system.

## WARNING

In operation, batteries generate and release flammable hydrogen gas, which, if ignited by a burning cigarette, naked flame, or spark, may cause battery explosion with dispersion of casing fragments and corrosive liquid electrolyte. So, carefully follow manufacturer's instructions for installation and service. Keep all sources of gas ignition away from the batteries and do not allow metallic articles to contact the negative and positive terminals of a battery at the same time.

## WARNING

A damaged or aged battery, in combination with the connected battery charger, can pose a serious health threat. The battery can produce hydrogen sulfide gas, which is characterized by its unique "rotten egg" smell. So, when a strong sulfurous odor is detected, remove power to the battery charger and check the battery for excessive heating. Do not inhale the fumes.

One end of the battery temperature probe cable has a three-pin plug, which plugs into a receptacle on the front of the battery charger. The other end, which has a temperature sensor sealed in it, should be attached to the negative battery post. If the battery temperature probe is defective or not installed, the red defective LED is lit.

- 7 On the front of the battery charger, if the red defective-temperature-probe LED is lit, fix the underlying problem before proceeding.
- 8 Switch the multimeter to the DC volts scale.

The **equipment side** of the fuse block is directly wired to the SmartScanNG<sup>2</sup> enclosure. The **battery side** of the fuse block is wired to the battery via the distribution block.

- 9 Touch the leads from the multimeter to the terminal on the equipment side of the fuse block.

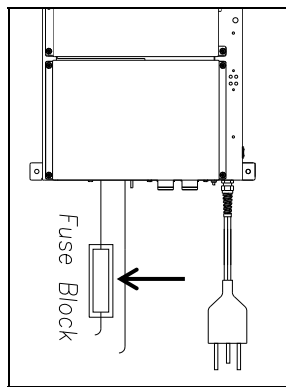

- 10** If voltage (on the equipment side of the fuse block) is 12.7 through 14.5 VDC, go to step **14**.
- 11** If voltage (on the equipment side of the fuse block) is 0 VDC:
- a** Touch the leads to the terminals on the battery side of the fuse block.
  - b** If voltage (on the battery side of the fuse block) is greater than 0 VDC, replace each fuse in the fuse block with a BAF-25 (25-amp 250-volt) fast-acting fuse and return to step **10**.
  - c** If voltage (on the battery side of the fuse block) is 0 VDC, fix any wiring problems between the fuse block, the distribution block, the battery, and the charger.
  - d** Return to step **10**.
- 12** If voltage is less than 12.7 VDC:

- a** On the battery charger, check the AC fuses to see if either is blown.

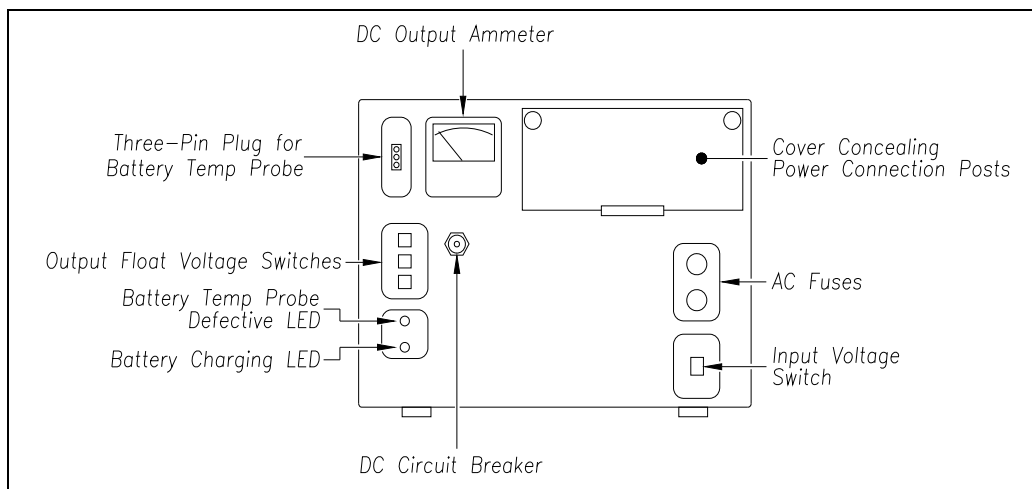

- b** If need be, replace with 4-amp 250-volt fast-acting fuses.
- c** On the battery charger, check the DC circuit breaker to see if it is open (tripped).  
When closed, about 0.09 inch (0.23 centimeters) of the breaker's button is seen. When open, the button is popped out, showing about 0.25 inch (0.64 centimeters).
- d** Check to see if the battery charger is plugged in.
- e** On the battery charger, check the battery-charging LED.  
If the battery is charging properly, the yellow battery-charging LED is lit solid. If one or more of the output float voltage switches are set between numbers, the yellow battery-charging LED flashes.
- f** If the yellow battery-charging LED isn't lit, call STC for help in fixing this problem.
- g** If the yellow battery-charging LED is lit solid, monitor the voltage for ten minutes.  
If the voltage is gradually increasing, the battery is probably charging. After the battery has charged for five hours, the battery voltage should be very near the float voltage setting. If the voltage isn't gradually increasing, the battery is probably not charging. This may indicate that the battery is defective and should be replaced.

- 13 If voltage is greater than 14.5 VDC, cut all power to the SmartScanNG<sup>2</sup> system and call STC for help in fixing this problem.
- 14 Toggle on the DC power switch on the right edge of the SmartScanNG<sup>2</sup> enclosure.

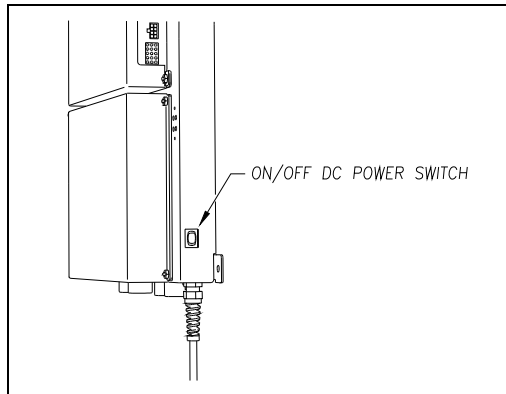

- 15 Wait 30 seconds.
- 16 On the display panel, look at the COP LEDs.

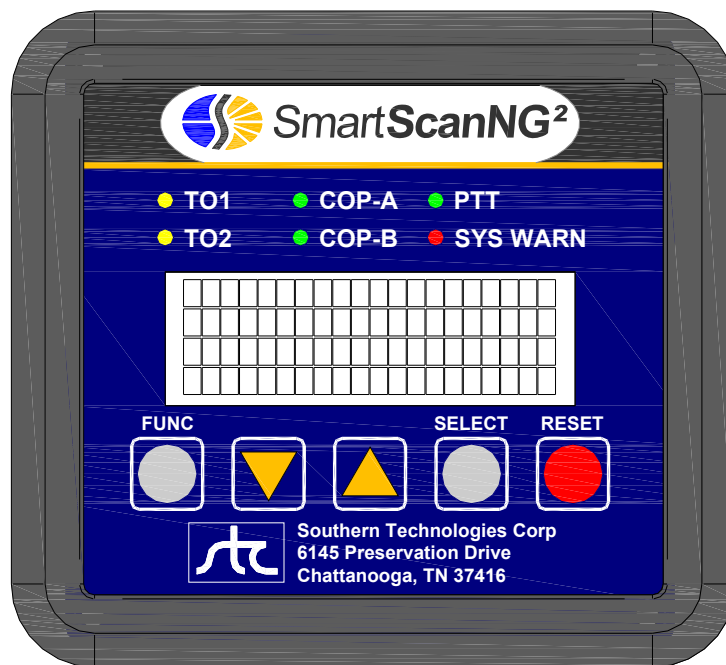

The COP-A and COP-B LEDs indicate the general health of each processor. If both the analyzer processor and the communications processor are running their programs correctly, their LEDs blink on and off. If a program isn't operating as expected, the LED for the affected processor is lit solid or isn't lit at all.

- 17 If either or both of the COP LEDs is lit solid or isn't lit at all, call STC for help in fixing this problem.

## 8.4 Checking the Scanner Shutters

To check the operation of the scanner shutters:

- 1 To use the serial interface to open the scanner shutters:
  - a Plug your computer into COM1 or COM2 (whichever is available) using a crossover (null-modem) cable.

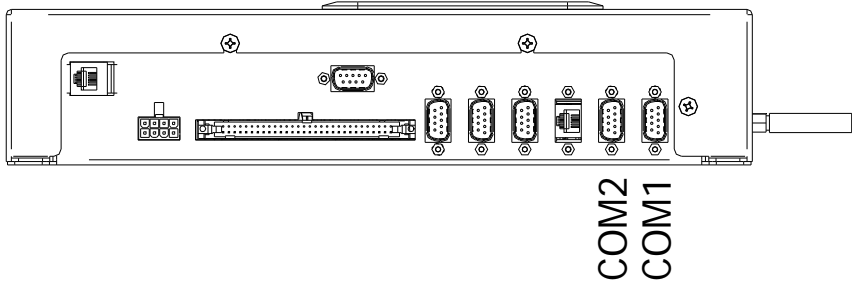

- b Turn on your computer.
- c Be sure that your computer has installed communications software, that it is set to use full duplex, and that the baud rate is set to 19,200.

Use your communications software to open a LOG file and capture the whole session to the file. When your session is complete, you may then view what you have done with an editor, print it with a printer, or store it for later retrieval.

- d On your computer, open a LOG file.
- e To get the Main menu, press **[Esc]**.

The Main menu appears.

```
SmartSCAN NG2
01/06/2016 11:09:55 EST
Main Menu - Comm
-----
      .
      .
[J] - Event log
[K] - System Functions Menu
[L] - Replay train
[M] - Security Menu
[X] - Exit
```



- f** Select Auto-Calibration to open the shutters.

The protective shutters in all scanners should open and stay open for three minutes. If it isn't enough time to check the shutters and optics, select option again.

```
System Functions Menu
-----
[A] - Radio Test
[B] - Vocabulary Test
[C] - Radio Inhibit
[D] - Start Manual Train
[E] - 1KHz Test Tone
[F] - Auto-Calibration
[G] - Remote System RESET
[H] - Delete All Stored Train Data
[I] - Clear Event Log
[J] - Get DHCP address
[K] - Update Menu
[M] - View maintenance statistics
[N] - Reset System Health
[O] - Maintenance email list
[R] - Volume up (3)
[S] - Volume down (3)
[T] - Web security settings
[X] - Exit
```

- g** In each scanner, check if its shutter opened.
- 2** If any shutter didn't open, fix this problem before proceeding.
  - 3** In each scanner, inspect optics and clean if necessary.
  - 4** If the date and time displayed on the top of the System Functions menu are incorrect, fix them before proceeding.
  - 5** To return to the Main menu, type **X**.
  - 6** To exit the serial interface and return the system to normal operation, type **X**.
  - 7** If this is a double-track site, repeat steps **1** through **7** for the other SmartScanNG<sup>2</sup> system.

## 8.5 Calibrating Scanners

The SmartScanNG<sup>2</sup> system self-calibrates its pyrometer interface circuitry. You need only put a preheated calibrated heat source on a scanner and place the system in autocalibration mode. The system then scans all pyrometer inputs until the signal from the calibrated heat source is located. The necessary adjustments to the related interface circuitry are automatically made while the system monitors its own progress by analyzing changes in the heat signals. Once the procedure has been completed, autocalibration mode is disengaged and the calibration results are displayed on your computer. The next two sections contain details for calibrating the bearing scanners and the wheel scanners.

### 8.5.1 Bearing Scanners

**STC recommends that you use the calibrated heat source (2100-810NG) only when the outside (ambient) temperature is above -18°C (0°F) and below 32°C (90°F).** If you must use it at other times, do so only when the needle is centered on the front of the temperature meter. If the needle isn't stabilized within  $\pm 2$  degrees of set point, the heat source isn't operating properly.

To calibrate the bearing scanners:

- 1 Be sure that you have on hand a STC calibrated heat source (2100-810NG) and a laptop computer.
- 2 On the control panel of the calibrated heat source, toggle the **Gating** switch off.
- 3 Plug the proper end of the supplied 50-foot (15-meter) power cord into the **six**-contact circular connector on the front of the calibrated heat source.

**Sixty Hz is critical for proper operation.** For a site that doesn't have a 120-volt 60-Hz power source, the heat source should be powered from a true sine wave inverter capable of 250 watts with an output of at least 110 volts at 60 Hz. The inverter should operate from an input voltage of 10.5 VDC to 15 VDC. A 120-volt USA socket should be provided to match the heat source power cord. The inverter should be grounded according to the manufacturer's recommendations.

#### **WARNING**

Once plugged in, both function connectors will have live AC present.

- 4 Using the supplied dust cap, cover the function connector that isn't being used.
- 5 Plug the other end of the power cord into the 120-volt USA socket.
- 6 On the control panel of the calibrated heat source, turn the temperature knob to **180°**.
- 7 Put the heat source in a shady area, out of direct sunlight and out of the wind.

- 8 Wait about 8 minutes for the heat source to reach operating temperature and stabilize.  
The heat source has reached operating temperature and stabilized when the temperature meter needle remains centered.  
Once the temperature stabilizes, calibration may begin. Once stabilized, the temperature will change less than plus-or-minus one degree Fahrenheit.
- 9 Take the calibrated heat source to the bearing scanner on the north or east rail.
- 10 With the power cord to the front of the scanner, place the calibrated heat source on the bearing scanner.

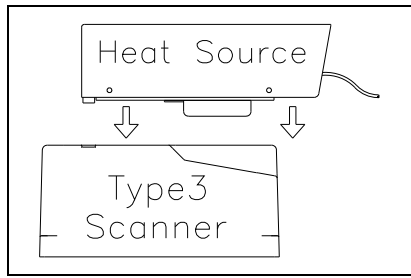

- 11 To prepare your computer:
  - a Plug your computer into COM1 or COM2 (whichever is available) using a crossover (null-modem) cable.

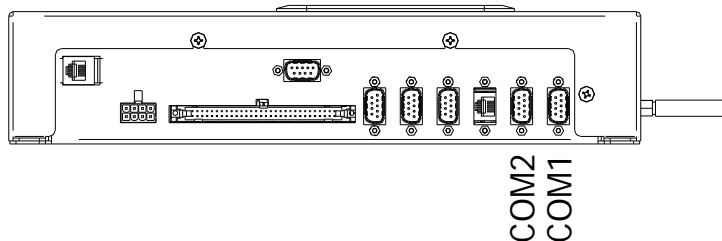

- b Turn on your computer.
- c Be sure that your computer has installed communications software, that it is set to use full duplex, and that the baud rate is set to 19,200.  
Use your communications software to open a LOG file and capture the whole session to the file. When your session is complete, you may then view what you have done with an editor, print it with a printer, or store it for later retrieval.
- d On your computer, open a LOG file.

**12** Using the serial interface, display the Main menu.

The Main menu looks like this.

```
SmartSCAN NG2
01/06/2016 11:12:45 EST
Main Menu - Comm
-----
      .
      .
      .
[K] - System Functions Menu
[L] - Replay train
[M] - Security Menu
[X] - Exit
```

**13** Select **System Functions** menu.

This prompt appears.

```
Type "System":
```

You are given unlimited chances to type the word "system." The entry of this word is **not** case sensitive. After you type it, the System Functions menu appears.

```
System Functions Menu
-----
[A] - Radio Test
[B] - Vocabulary Test
[C] - Radio Inhibit
[D] - Start Manual Train
[E] - 1KHz Test Tone
[F] - Auto-Calibration
[G] - Remote System RESET
[H] - Delete All Stored Train Data
[I] - Clear Event Log
[J] - Get DHCP address
[K] - Update Menu
[M] - View maintenance statistics
[N] - Reset System Health
[O] - Maintenance email list
[R] - Volume up (3)
[S] - Volume down (3)
[T] - Web security settings
[X] - Exit
```

The **Auto-Calibration** option is used to calibrate the system's pyrometer interface circuitry.

#### 14 Select Auto-Calibration.

The SmartScanNG<sup>2</sup> system will now calibrate itself. **Follow along on your computer screen until you see "Auto-Calibration Disengaged."** This message is an indication that the system is done with the calibration procedure. To abort the process, press **[Esc]** on your computer or remove the heat source from the bearing scanner.

On your computer screen, an acceptable calibration looks like this. Your values will be different.

```
Auto Calibration Selected

Signal levels in millivolts with closed shutters
  Rail1          Rail2          Wheel1          Wheel2
Min/Max/Average Min/Max/Average Min/Max/Average Min/Max/Average
0  80  20      0  60  20      0  60  20      20  80  40

Opening the shutters.
Scanning for heat source. Press the 'Esc' key to abort.
Located 187F heat source at Rail1. Auto-calibration beginning in 0 secs.

.....Auto-Calibration Engaged.....

Testing Digital-Pot U-306. Stand by.
Digital-pot checks OK.
Previous calibrated digital-pot. setting was 38.
Adjusting digital-pot.
Temp = 225F Pot = 59 Sec = 1 Pot. decremented by 1 step.
Temp = 224F Pot = 58 Sec = 1 Pot. decremented by 1 step.
Temp = 221F Pot = 57 Sec = 2 Pot. decremented by 1 step.
Temp = 219F Pot = 56 Sec = 3 Pot. decremented by 1 step.
.
.
.
Temp = 183F Pot = 35 Sec = 15 Pot. decremented by 1 step.
Temp = 182F Pot = 34 Sec = 18 Pot. decremented by 1 step.
Temp = 181F Pot = 33 Sec = 29 Pot. decremented by 1 step.
Temp = 179F Pot = 33 Sec = 93 Monitoring heat source temperature.
Rail1 digital-pot setting of 33 was stored in EEPROM.
East Rail Scanner Calibration complete.
The setpoint is 180F. The calibrated temp. is 179F.
Closing the shutters.
Resistor test pending.

.....Auto-Calibration Disengaged.....
```

Before the shutters are opened, if you get a signal level greater than 200 millivolts, it usually means that there is noise on the scanner inputs, which most times is caused by an electrical problem with the scanner. If you cannot isolate and fix the cause of this problem, call STC for help.

```

Auto Calibration Selected

Signal levels in millivolts with closed shutters
  Rail1          Rail2          Wheel1          Wheel2
Min/Max/Average Min/Max/Average Min/Max/Average Min/Max/Average
210 250 210      0 60 20      0 60 20      20 80 40
  .
  .
  .
  
```

Before the shutters are closed, if you don't get a calibrated temperature in the range 178°F to 182°F, it means that the scanner wasn't calibrated. If cleaning the optics doesn't solve your problem, replace the scanner cover-and-module assembly. If this doesn't solve your problem, call STC for help in fixing the problem.

- 15** When "Auto-Calibration Disengaged" is displayed on your computer, remove the calibrated heat source.
- 16** Take the calibrated heat source to the bearing scanner on the south or west rail.
- 17** With the power cord to the front of the scanner, place the calibrated heat source on the bearing scanner.

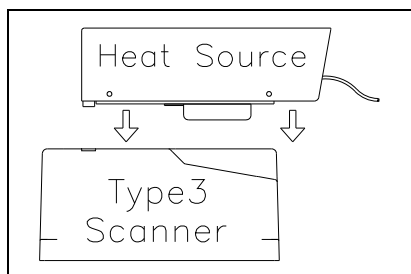

- 18** Repeat steps **14** through **15**.
- 19** To return to the Main menu, type **X**
- 20** To exit the serial interface and return the system to normal operation, type **X**
- 21** If this is a double-track site, repeat steps **1** through **20** for the second track.

## 8.5.2 Wheel Scanners

Not all sites use wheel scanners. If your site doesn't use them, skip ahead to the next section.

**STC recommends that you use the calibrated heat source (2100-810NG) only when the outside (ambient) temperature is above -18°C (0°F) and below 32°C (90°F).** If you must use it at other times, do so only when the needle is centered on the front of the temperature meter. If the needle isn't stabilized within  $\pm 2$  degrees of set point, the heat source isn't operating properly.

To calibrate the wheel scanners:

- 1 Be sure that you have on hand a STC calibrated heat source (2100-810NG) and a laptop computer. The wheel scanner calibration procedure is the same as that for bearing scanners.

**NOTE:**

The black filter frames **MUST** be installed during wheel scanner calibration! After calibration is complete, exchange the black filter frame with the red. The red filter frame should be installed for normal wheel scanning operation.

- 2 With the power cord to the front of the scanner, place the calibrated heat source on the north or east wheel scanner.

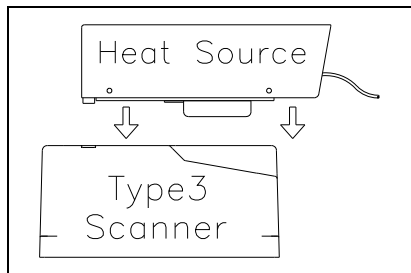

- 3 Begin autocalibration. Refer to 8.5.1 Bearing Scanners for details.
- 4 Select Auto-Calibration from **System Functions** menu.

The SmartScanNG<sup>2</sup> system will now calibrate itself. **Follow along on your computer screen until you see "Auto-Calibration Disengaged."** This message is an indication that the system is done with the calibration procedure. To abort the process, press **[Esc]** on your computer or remove the heat source from the wheel scanner.

Before the shutters are opened, if you get a signal level greater than 200 millivolts, it usually means that there is noise on the scanner inputs, which most times is caused by an electrical problem with the scanner. If you cannot isolate and fix the cause of this problem, call STC for help.

Before the shutters are closed, if you don't get a calibrated temperature in the range 540°F  $\pm$  6°F, it means that the scanner wasn't calibrated. If cleaning the optics doesn't solve your problem, replace the scanner cover-and-module assembly. If this doesn't solve your problem, call STC for help in fixing the problem.

- 5 When "Auto-Calibration Disengaged" is displayed on your computer, remove the calibrated heat source.

- 6 Take the calibrated heat source to the wheel scanner on the south or west rail.
- 7 With the power cord to the front of the scanner, place the calibrated heat source on the wheel scanner.

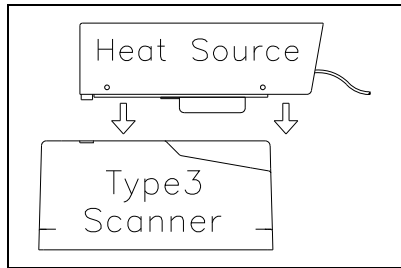

- 8 Repeat steps 3 through 5.
- 9 To return to the Main menu, type **X**.
- 10 To exit the serial interface and return the system to normal operation, type **X**.
- 11 Replace the black filter frame with the red one in both wheel scanners.  
Before continuing, be sure that for each wheel scanner that the red filter frame is securely in place, that the hole on top of the wheel scanner cover is facing the center of the track, and that the four socket-head-cap screws on the weather cover are completely tight.
- 12 If this is a double-track site, repeat steps 1 through 11 for the second track.



## 8.6 Calibrating the Zepic III Presence Detector

1. From the center of the gating transducers, measure the shortest distance you want the track circuit to pick up the presence of a train.
2. The distance must be at least 25' (7.62 m) and no more than 150' (45.7 m).
3. At the point just measured, place a 0.06Ω shunt across both rails. The track must be shunted before calibration button is pressed.
4. Remove cover of SmartSCAN-NG and locate the Zepic III Presence Detector board. Press and HOLD the blue RCVR CAL button until the relay drive LED starts blinking. Release the RCVR CAL button and the LED will stop blinking. The ZEPIC III will automatically begin the calibration process. NOTE: The track shunt MUST remain in place during the calibration process.

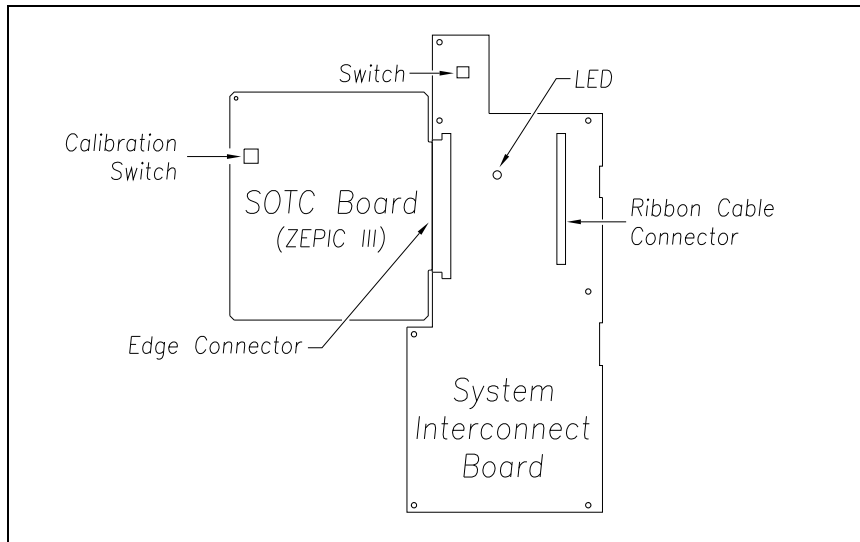

5. The relay drive will pick up (LED on) when the unit has successfully calibrated. This process can take up to 45 seconds to complete.

### Verification

1. Lift the shunt, and the relay drive should drop.
2. Move the shunt 10' farther out from the calibration point and verify the relay drive does not pick up.
3. **IMPORTANT:** To ensure accurate activation point, always place the shunt BEFORE pressing the RCVR CAL button.  
If the ZEPIC cannot achieve calibration, it will blink the relay drive LED three (3) times in rapid succession, indicating a calibration error. The unit will continuously repeat the calibration procedure (there is no need to press the blue RCVR CAL button), allowing you to troubleshoot the track circuit, wiring, and battery. Once the issue has been corrected, repeat the calibration procedure outlined in steps 2 - 4.

Because the ZEPIC III is a two-wire system, it will activate an equal distance on both sides of the track feed point.

## 8.7 Checking the Broadcast

The **Radio Test option** on the System Functions menu is used to broadcast a short message through the speaker and through the radio. Similarly, the **1KHz Test Tone option** on the System Functions menu is used to generate a continuous tone for about 10 seconds through the speaker and through the radio. Using either of these options will let you verify that the speaker and radio are working properly.

To check the operation of the speaker and the radio:

- 1 Using the serial interface, display the Main menu.

The Main menu looks like this.

```
      .
      .
      .
[I] - Setup
[J] - Event log
[K] - System Functions Menu
[L] - Replay train
[M] - Security Menu
[X] - Exit
```

- 2 Select the **System Functions** menu.

This prompt appears.

```
System Functions Menu
-----
[A] - Radio Test
[B] - Vocabulary Test
[C] - Radio Inhibit
[D] - Start Manual Train
[E] - 1KHz Test Tone
[F] - Auto-Calibration
[G] - Remote System RESET
[H] - Delete All Stored Train Data
[I] - Clear Event Log
[J] - Get DHCP address
[K] - Update Menu
[M] - View maintenance statistics
[N] - Reset System Health
[O] - Maintenance email list
[R] - Volume up (3)
[S] - Volume down (3)
[T] - Web security settings
[X] - Exit
```

- 3 Select **Volume up** or **Volume down** options of the System Functions menu to adjust the speaker volume.
- 4 To start outputting either the phrases or the tones, select **Radio Test** or **1KHz Test Tone**.

If the system isn't currently making any other voice announcements, it begins the message or tone. After the message or tone finishes, the System Functions menu reappears.

If the system is currently making a voice announcement, the firmware displays the message "System Is Currently Making Voice Announcements! Try Again Later" and redisplay the System Functions menu.

- 5 While listening to the message or tone, look at the display panel.

The **PTT LED** should be lit.

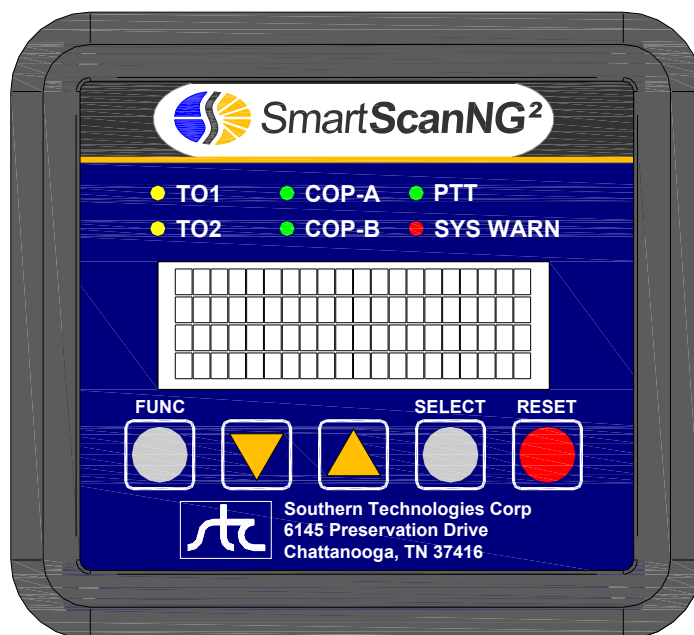

If this LED isn't lit, the system's ability to send a message or tone to the radio might be inhibited. This can happen when one uses the **Radio Inhibit option** on the System Functions menu. If the radio is inhibited, the results of this check are invalid.

The **Radio Inhibit option** prevents radio activation for three minutes. During this time, any announcements generated by the system are broadcast through the speaker, but not through the radio.

- 6 If the **PTT LED** isn't lit and the radio is inhibited, wait three minutes and return to step 4.
- 7 If the **PTT LED** isn't lit and the radio isn't inhibited, call STC for help in fixing this problem.
- 8 To return to the Main menu, type **X**.
- 9 To exit the serial interface and return the system to normal operation, type **X**.

- 10 If this is a double-track site, repeat steps 1 through 9 for the other SmartScanNG<sup>2</sup> system.

## 8.8 Checking the Speech Data

The **Vocabulary Test option** on the System Functions menu is used to enunciate all of the stored speech phrases. This announcement is broadcast through the speaker, but not through the radio. Therefore, it isn't affected by the **Radio Inhibit option** on the System Functions menu being enabled. The text of the message is specific to each railroad.

To check the integrity of the speech data:

- 1 Using the serial interface, display the Main menu.

The Main menu looks like this.

```
      .
      .
      .
[J] - Event log
[K] - System Functions Menu
[L] - Replay train
[M] - Security Menu
[X] - Exit
```

- 2 Select **System Functions** menu.

```
System Functions Menu
-----
[A] - Radio Test
[B] - Vocabulary Test
[C] - Radio Inhibit
[D] - Start Manual Train
      .
      .
      .
```

- 3 Select **Volume up** or **Volume down** options of the System Functions menu to adjust the speaker volume.
- 4 From the System Functions menu, select **Vocabulary Test**.

This message appears.

```
Vocabulary test started
```

If the system isn't currently making any other voice announcements, it begins the vocabulary-test announcement. After the announcement finishes, the System Functions menu reappears.

If the system is currently making a voice announcement, the firmware displays the "System Is Currently Making Voice Announcements! Try Again Later" message and the System Functions menu reappears.

- 5 If you hear nothing or speech that is too garbled to understand, call STC for help in fixing this problem.
- 6 To return to the Main menu, type **X**.
- 7 To exit the serial interface and return the system to normal operation, type **X**.
- 8 If this is a double-track site, repeat steps 1 through 7 for the other SmartScanNG<sup>2</sup> system.

## 8.9 Generating Test Trains

To generate a test train to check simulated alarms:

1. Using the serial interface, display the Main menu.

The Main menu looks like this.

```
      .
      .
      .
[J] - Event log
[K] - System Functions Menu
[L] - Replay train
[M] - Security Menu
[X] - Exit
```

2. Select the **System Functions** menu.

```
System Functions Menu
-----
[A] - Radio Test
[B] - Vocabulary Test
[C] - Radio Inhibit
[D] - Start Manual Train
[E] - 1KHz Test Tone
      .
      .
      .
```

3. From the System Functions menu, select **Start Manual Train**.

This prompt appears.

```
Manual train started.

Train Arrival

Train Departure
```

In Manual Train Mode, the system opens all the shutters and simulates transducer pulses for about one minute. During this time, a person can check various aspects of the installed components. In this mode, the system runs the ramp function without generating heats. The train is marked as a test train. There won't be any voltage applied to the scanner inputs.

This is a timed test that should gate approximately 164 simulated axles. You can stop this test by selecting the Stop Manual Train option.

The data generated for this test train is stored in the Test Train directory, which contains data on the last test train only. The Last Test Train report gets its data from this directory.

There will be an arrival message broadcast through the speaker only. During test train, the TO1 & TO2 LEDs on the Display Panel will flash with each simulated axle.

After about a minute, this prompt appears and the post train announcements will be broadcast over the speaker.

4. To generate a test train to check hot bearings:

**STC recommends that you use the calibrated heat source (2100-810NG) only when the outside (ambient) temperature is above -18°C (0°F) and below 32°C (90°F).** If you must use it at other times, do so only when the needle is centered on the front of the temperature meter. If the needle isn't stabilized within  $\pm 2$  degrees of set point, the heat source isn't operating properly.

a. Ready the calibrated heat source.

After powering it up, let the heat source sit in the shade and out of the wind for at least 8 minutes to stabilize. The heat source has reached operating temperature and stabilized when the temperature meter needle remains centered.

b. With the power cord to the front of the scanner, place the calibrated heat source on the bearing scanner that is on the rail with the gating transducers.

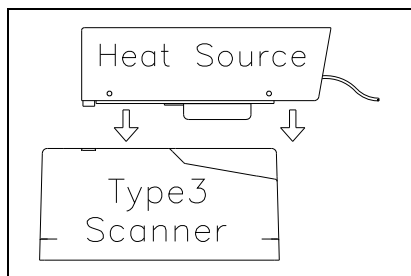

c. Quickly stroke the top of each gating transducer with a metal wrench, alternating between TO1 and TO2 for a total of **six** simulated axles.

You should hear the real-time defect message. No matter how many defects are found, the real-time defect message is only announced once.

d. Wait for the system to time out, which normally takes about 10 seconds.

You should hear an end-of-train message with six Hotbox alarms. Per train, the system only announces a maximum of six total alarms.

e. Listen to be sure that the Hotbox alarms are announced and that they are announced for the correct side.

If you do not hear anything, no alarm-level heat was recorded. No measurable heat from a bearing scanner may be due to loose connections, a scanner not being connected to the bottom of the SmartScanNG<sup>2</sup> enclosure, a defective shutter motor in the scanner, or a damaged scanner.

- f. If you do not hear any Hotbox alarms being announced, fix this problem before proceeding.
- g. If the Hotbox alarms are announced for the wrong side, switch the bearing scanner connections on the bottom of the SmartScanNG<sup>2</sup> enclosure.
- h. Repeat the test, this time placing the calibrated heat source on the bearing scanner on the opposite rail.
- i. Verify the results as before.  
If the results are correct, your system should function properly when scanning the bearings of real trains.
- j. Remove the calibrated heat source.
- k. If this is a double-track site, repeat steps **1** through **10** for the other SmartScanNG<sup>2</sup> system.
- l. Store the calibrated heat source and its power cord in the wayside enclosure.

## 8.10 Setting Transducer Gain

The Equipment menu shows whether the transducer-gain setting is normal or high. Regardless of the setting, the SmartScanNG<sup>2</sup> system starts every train with the transducer input comparator set to high mode. Then, if the train is traveling 20 mph (32 kph) or more and if the transducer gain was set to normal mode, the transducer input comparator switches to normal mode. This means that it is rarely necessary to set this option to high. **Normal is the recommended starting position.**

When the comparator is in high mode, the comparator converts lower voltage pulses from the transducer into output pulses. This causes the system to be more sensitive to transducer output. When the comparator is in normal mode, the comparator has a better chance of filtering transducer pulses not caused by a wheel.

To set the transducer-gain setting to normal:

- 1 Using the serial interface, display the Main menu.

The Main menu looks like this.

```
      :
      :
[H] - Test Menu
[I] - Setup
[J] - Event log
[K] - System Functions Menu
[L] - Replay train
[M] - Security Menu
[X] - Exit
```

**2** Select the **Setup** menu.

If the Setup menu is password protected, this prompt appears.

```
You are not logged in with admin privileges
Enter password:
```

You are given three chances to type the correct password. When you don't type the correct password in three tries, the system returns to the Main menu.

Each time you incorrectly type the password, this error message appears.

```
Password Incorrect
```

If the password is less than 11 characters long, press **[Enter]** after typing the last character. If the password is the full 11 characters in length, pressing **[Enter]** isn't necessary.

The entry of the password is case sensitive. For example, the password "abc123" cannot be entered "ABC123."

If the Setup menu is not password protected, the Setup menu appears. Also, after you type the password correctly for a password protected Setup menu, the Setup menu appears.

```
STC SmartScanNG, MP/KP-1234.5
01/06/2016 16:02:49 EST
Setup Menu
-----
[A] - Date and Time
[B] - MP/KP
[C] - Alarm Settings
[D] - Equipment Settings
[E] - Messages Settings
      .
      .
```

**3** Select **Equipment** menu.

```
      .
      .
[J] - Winter Cycle ..... NO
[K] - Transducer Gain ..... Normal
[L] - AEI ..... NO
      .
      .
      .
```

The Equipment menu shows whether the transducer-gain setting is normal or high.



- 4 If the **Transducer Gain option** on the Equipment menu is set to Normal, go to step 6.  
If the **Transducer Gain option** on the Equipment menu is set to High, select option to toggle setting from High to Normal. The **Transducer Gain option** on the Equipment menu changes and the Equipment menu reappears.
- 5 To leave the Equipment menu and return to the Setup menu, type **X**.
- 6 To leave the Setup menu and return to the Main menu, type **X**.  
Changes to the system parameters aren't reflected until after you have exited the Setup menu.
- 7 To exit the serial interface and return the system to normal operation, type **X**.
- 8 Leave the SmartScanNG<sup>2</sup> enclosure and the battery charger plugged in, powered, and turned on.
- 9 If this is a double-track site, repeat steps 1 through 9 for the other SmartScanNG<sup>2</sup> system.
- 10 Wait until 20 or more trains have passed over the site.

**Do the steps that follow after 20 or more trains have passed over the site.**

## 8.11 Doing the Final Activities

To do the final activities:

- 1 **Be sure that at least 20 trains have passed over the site.**

You are not done (that is, you have not placed the system in service) until all the steps below are done.

- 2 On the display panel, look at the **SYS WARN LED**.

The System Health Menu provides a snapshot of the system's general health. If a system warning has been flagged, the SYS WARN LED will be lit and the Check System Health message will be displayed on the bottom text line of the home screen. The Sys. Health Menu provides a status indicator for the various system health checks.

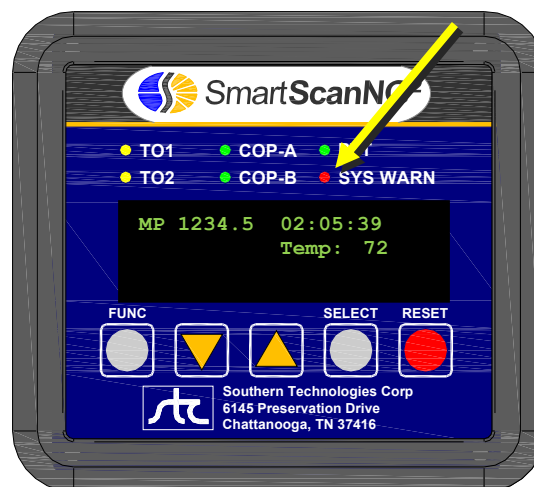

**SmartScanNG<sup>2</sup> Display Panel**

- 3 If the SYS WARN LED is unlit, the system has passed all health checks. Go to step 5.
- 4 If the SYS WARN LED is lit, one or more health checks have failed. Navigate to the Sys.Health Menu using the display panel keypad. Scroll through the displayed status indicators to determine which subsystems are affected. Fix these issues before proceeding.
- 5 To see if the system is being activated by the gating transducers:
  - a Produce a Train Detail report for the last recorded train.

From the Main menu, select **Train Detail**.

```

SmartSCAN NG2
11/25/1975 12:49:54 EST
Main Menu - Comm
-----
[A] - Train Summary
[B] - Train Detail
[C] - Exception Summary
[D] - Exception Detail
      .
      .
      .
  
```

- b On the Train Detail report, check under the System Alarms section of the report for the words "No Approach Track."
 

The No Approach Track alarm indicates that the system presence detection system (that is, the advance transducers) didn't detect the arrival of the train at the site. Instead, the system started the train scanning process when a gating transducer sensed the train.
  - c If the words "No Approach Track" don't appear, go to step **12**.  
You'll next verify that that each advance transducer is functional.
- 6 Using a metal wrench, stroke the top of one of the advance transducers.  
The scanner shutters should open completely for 10 seconds.
- 7 On one of the bearing scanners, check to see if the shutter opens.
- 8 If the shutter didn't open, fix this problem before proceeding.
- 9 Using a metal wrench, stroke the top of the other advance transducer.  
The scanner shutters should open completely for 10 seconds.
- 10 On one of the bearing scanners, check to see if the shutter opens.
- 11 If the shutter didn't open, fix this problem before proceeding.

**12** Produce a Train Summary report.

From the Main menu, select **Train Summary**.

```
SmartSCAN NG2
11/25/1975 12:49:54 EST
Main Menu - Comm
-----
[A] - Train Summary
[B] - Train Detail
[C] - Exception Summary
[D] - Exception Detail
      .
      .
      .
```

The Train Summary report lists all trains currently stored in the Trains directory. A line of information is shown for each train entry. The report is divided into a header section and a detail section. The header section contains general information about the site. The detail section contains summary information on each train that passed the site.

**13** On the Train Summary report, check the Axles column.

Axle count should be an even number. Odd numbered axle counts are possible indications of gating transducer problems.

**14** If there is an odd axle count and if train speed was always above 7 mph (11.3 kph), go to step **16**.

If at any time during train passage the train speed was less than or equal to 7 mph (11.3 kph), gating transducer problems probably don't exist. If the train speed was always above 7 mph (11.3 kph), gating transducer problems probably do exist.

The Very Slow Train alarm indicates that, at some point during train passage, four consecutive axles crossed the gating transducers at a speed of 7 mph (11.3 kph) or less. This alarm appears on a Train Detail report.

If there are many very slow trains (that is, many trains traveling less than 7 mph (11.3 kph) at this site, it may be necessary to relocate the scanners and other track hardware to a better location. Deciding to do this should be made in consultation with STC. Relocating a site is beyond the scope of this document.

**15** If there is an even axle count and the values under "Axles", "TO1," and "TO2" are the same, go to step **24**.

If things are working correctly, all three values for a given train should be equal. Do the next step only if things aren't working correctly.

**16** At trackside, check all transducer-mounting bolts on all tracks to make sure that all transducers are snug against the rail.

Four bolts are needed to hold the transducer in place. Two square-head bolts go through the mounting plate and transducer body. Two hex-head bolts go through the mounting plate and rail. If any of these bolts are sheared or missing, they must be replaced with the correct replacement bolt. Also, if any washers or nuts are missing, they must be replaced.

17 If all transducers aren't snug against the rail, fix this problem before proceeding.

Each installed transducer body should be 1-9/16 inches (3.97 centimeters) below the top of the rail and parallel to it. You can meet this requirement by using the transducer height bracket on the bottom of the alignment fixture.

18 Place the alignment fixture across both rails, centered over each transducer in turn.

19 Check if each transducer body just touches the bracket.

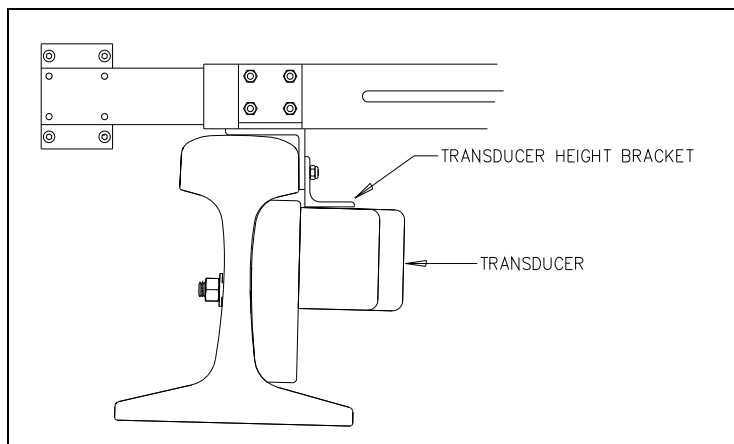

The fixture should be snug against the top and gauge of both rails. This may be impossible if the transducer body is less than 1-9/16 inches (3.97 centimeters) below the top of the rail or if the transducer body isn't parallel to the top of the rail.

20 If a transducer body doesn't just touch the bracket:

- a Loosen the nuts holding the transducer body to its mounting plate.
- b By sliding it up and down, adjust the transducer body to the proper height.
- c Tighten each hex nut with a 9/16-inch torque wrench to a **torque of 12 to 15 foot-pounds (16.3 to 20.3 newton-meters)**.

**Don't exceed a torque of 15 foot-pounds (20.3 newton-meters). Doing so can weaken or break a bolt, requiring the bolt to be replaced.**

d Wait until 20 more trains have passed over the site and then return to step 1.

**21** Determine which gating transducer is recording incorrect information.

Determine which gating transducer is recording incorrect axle counts and whether it isn't counting all axles or counting extra ones. You may not be able to do this by just looking at the values under the Axles, TO1, and TO2 columns of the Train Summary report. Sometimes, a transducer problem causes the number in the Axles column to be incorrect. Therefore, the true axle count may have to be determined from an alternate source such as the next detector system that encounters the train with the transducer-count imbalance.

After you determine which gating transducer is miscounting, you'll need to change a jumper setting on the Interface board. If TO1 is the problem, you'll change the setting for J201. If TO2 is the problem, you'll change the setting for J202. If both TO1 and TO2 have a problem, both jumpers will need to be changed. Changes to the jumpers should be made only after all external conditions that cause transducer miscounts have been corrected. Some of these external conditions are improperly installed transducers, loose transducer bolts, incorrect transducer heights, damaged transducers, damaged transducer cables, and loose wiring connections.

The process of adjusting the transducer loading is trial and error. Generally, if you are having too many transducer counts, lower the loading resistance to make the transducer less sensitive. Likewise, too few counts suggest that the transducer isn't sensitive enough, so you would select a loading value with more resistance.

**22** If the selected gating transducer appears to be missing axles (that is, the transducer that is showing a number of hits less than the true axle count):

- a** Toggle off the DC power switch on the right edge of the SmartScanNG<sup>2</sup> enclosure.

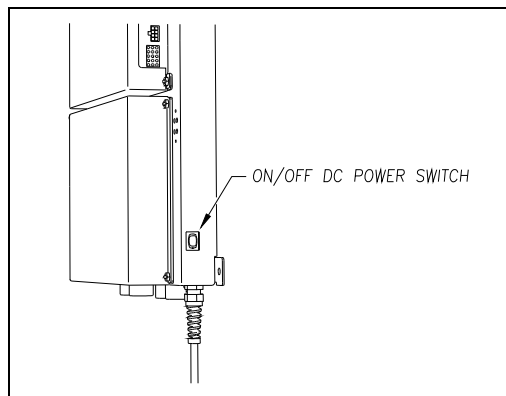

- b** Remove the six nuts and three screws holding the cover over the Interface board.

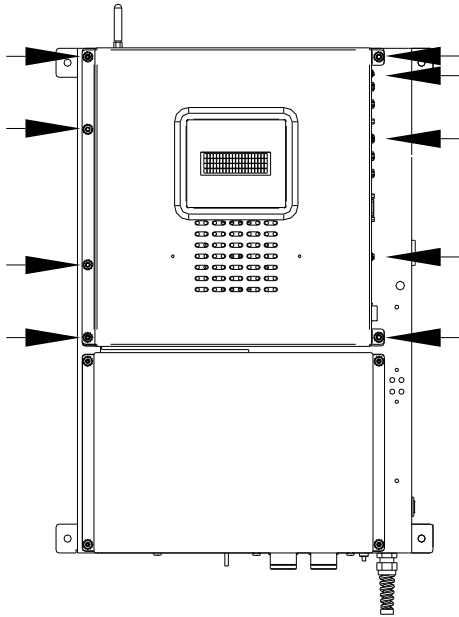

The Interface board is now visible.

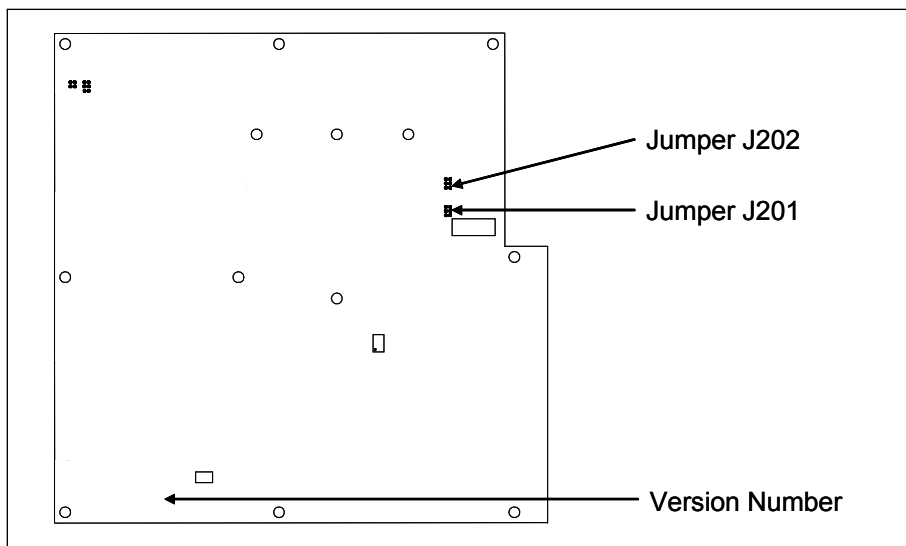

- c** To prevent the base assembly from falling, replace two of the just removed nuts onto the top two mounting studs on the SmartScanNG<sup>2</sup> enclosure.
- d** Store the removed cover, three screws, and remaining four nuts in a safe place until you replace them.

The available loading sensitivities vary depending on which version of Interface board you have and whether resistors are attached to the jumpers or not. The version number is printed on the lower-left edge of the board.

- e The table below lists the highest, middle, and lowest sensitivity for transducer loading for current board versions. Highest is the most sensitive.

<b>J201 or J202 Jumper Position</b>	<b>Sensitivity Level</b>
Top	Lowest Sensitivity
Center	Middle Sensitivity
Bottom	Highest Sensitivity

- f If TO1 is missing axles, move the J201 jumper to the next higher sensitivity position. If it is currently on the highest sensitivity position, call STC for help in fixing this problem.
  - g If TO2 is missing axles, move the J202 jumper to the next higher sensitivity position. If it is currently on the highest sensitivity position, call STC for help in fixing this problem.
  - h Remove the two nuts holding the base assembly to the SmartScanNG<sup>2</sup> enclosure.
  - i Using the saved six nuts and three screws, reattach the cover over the Interface board.
  - j Toggle on the DC power switch on the right edge of the SmartScanNG<sup>2</sup> enclosure.
  - k Wait until 20 more trains have passed over the site and then return to step 1.
- 23 If the selected gating transducer appears to be counting extra axles (that is, the transducer that is showing a number of hits more than the true axle count):

- a Access Interface Board as detailed in Step 23.

The available loading sensitivities vary depending on which version of Interface board you have and whether resistors are attached to the jumpers or not. The version number is printed on the lower-left edge of the board.

- b The table below lists the highest, middle, and lowest sensitivity for transducer loading for current board versions. Highest is the most sensitive. The jumper's top position is the one closest to the external speaker.

<b>J201 or J202 Jumper Position</b>	<b>Sensitivity Level</b>
Top	Lowest Sensitivity
Center	Middle Sensitivity
Bottom	Highest Sensitivity

- f If TO1 is recording extra axles, move the J201 jumper to the next lower sensitivity position. If is currently on the lowest sensitivity position, call STC for help in fixing this problem.
- g If TO2 is recording extra axles, move the J202 jumper to the next lower sensitivity position. If is currently on the lowest sensitivity position, call STC for help in fixing this problem.
- h Reattach the cover over the Interface board.

- i Toggle on the DC power switch on the right edge of the SmartScanNG<sup>2</sup> enclosure.
  - j Wait until 20 more trains have passed over the site and then return to step 1.
- 24** On the Train Summary report, check the column marked "Average."  
For each train, the values in the two columns under this heading should be within four degrees of each other.
- 25** If the columns aren't within four degrees and if the scanner optics are clean, recalibrate and realign the scanner.
- 26** On the Train Summary report, check the last column of the report.  
The last column shows the system battery voltage when each train passed the site. It should show values between 12.7 and 14.5 volts. Values outside this range may be caused by:
- No AC power for an extended period
  - Improperly adjusted float voltage
  - Defective battery
  - Blown fuses
  - Defective battery charger
- 27** If the most recent value isn't between 12.7 and 14.5 volts, investigate and fix any problems before proceeding.
- 28** Leave the SmartScanNG<sup>2</sup> enclosure and the battery charger plugged in, powered, and turned on.
- 29** If this is a double-track site, repeat steps 1 through 28 for the other track (that is, for the other SmartScanNG<sup>2</sup> system).



## 9.0 Customer Service

---

At STC, the customer is number one. STC is committed to products that work and customers that are satisfied. Nothing less is acceptable. This section tells how to get answers for questions, fixes for problems, and parts for spares.

### 9.1 Reaching STC

You can reach STC by mail, telephone, fax, and email. By mail, you can reach STC at:

Southern Technologies Corporation  
6145 Preservation Drive  
Chattanooga, Tennessee 37416-3638  
USA

Mail and shipments are replied to as soon as possible, normally within one working day. Equipment repair usually takes longer.

By telephone, except on major holidays, you can reach STC at 423-892-3029, Monday through Friday, from 8:00 a.m. until 5:00 p.m. Eastern time. After business hours, a machine answers the calls. These calls are returned promptly the next business day. By fax, you can reach STC at 423-499-0045. The fax machine can receive faxes at all times. Faxes are replied to as soon as possible, normally within one working day. By email, you can reach STC at [stcemail@southern-tech.com](mailto:stcemail@southern-tech.com). Email is replied to as soon as possible, normally within one working day.

### 9.2 Returning Equipment for Repair

Return any damaged, defective, or malfunctioning equipment to STC for repair or replacement. You don't need a return authorization number. You don't even need to make a telephone call first. Just ship it directly to the **Repair Department** at the address above.

With the returned equipment, include:

- Complete address of where the equipment is to be returned
- Name and telephone number of person who should be contacted to answer questions about the equipment
- Written explanation of the equipment defect or malfunction
- Any reports or other data that would be helpful in diagnosing the problem
- If out of warranty, a Purchase Order Number for the order or credit card number (to be charged) with its expiration date

### 9.3 Reporting Problems or Suggestions

If you have any problems, suggestions, or questions related to STC equipment, telephone the **Engineering Department** at the telephone number above. When calling, state the equipment you're calling about. Your call will then be directed to the right person.

### 9.4 Ordering Spare Parts

If you need any spare parts to support STC equipment, telephone or fax the **Sales Department** at the telephone numbers above.

When calling, state that you're calling to order parts. Your call will then be directed to the right person. When placing the order, reference the STC part numbers listed in this guide. However, if you don't have the part numbers, the sales staff can obtain them for you and provide you with current pricing and availability.

When faxing, include:

- Purchase Order Number for the order or credit card number (to be charged) with its expiration date.
- Complete address where the parts are to be shipped.
- Complete address where the invoice is to be mailed.
- Name and telephone number of the person who should be contacted to answer questions about the order.
- Your fax number, if available.
- For each item ordered, part number, complete description, and quantity needed.

### 9.5 Checking on Shipments and Orders

If you need to check on the status of any shipment or order, telephone or fax the **Sales Department** at the telephone numbers above.

When calling, state that you're checking the status of a shipment or order. Your call will then be directed to the right person. Have your Purchase Order Number ready when you call. However, if you don't have the order number, the sales staff can locate your order number and provide you with the status of the shipment or order.

When faxing, include:

- Purchase Order Number for the shipment or order being checked.
- Name and telephone number of the person who should be contacted after the order status is checked.
- Your fax number, if available.

# Index

---

This section lists the page numbers for keywords and phrases used in this guide.

## A

AAR, 35, 37  
AEI antennas, 35, 61  
AEI Interface module, 22, 35, 36, 37, 61, 62  
AEI tags, 35, 37  
AI1200 Reader Logic board, 35  
**Alarms**  
    High Wide alarms, 63  
    Hotbox alarms, 86, 87  
    No Approach Track alarm, 90  
    Very Slow Train alarm, 91  
alignment fixture, 65, 92  
Announcements, 83, 84  
AR2200 RF unit, 35  
arresters, 61  
ATA, 35, 37  
autocalibration, 15, 73, 74, 77, 79  
Auto-Calibration, 15  
auxiliary-alarm, 10  
axle count, 91, 93, 95

## B

ballast, 42, 44, 47, 66  
batteries, 6, 29, 53, 69  
battery charger, 29, 30, 31, 44, 49, 50, 52, 53, 67, 68, 69, 70, 89, 96  
battery temperature probe, 30, 53, 69  
baud rate, 72, 75  
bearing scanners, 10, 41, 42, 46, 54, 74, 79, 90

## C

calibrated heat source, 15, 74, 75, 78, 79, 80, 86, 87  
COM1, 16, 22, 59, 72, 75  
COM2, 16, 22, 72, 75  
COM4, 22, 59  
COM5, 22, 36, 61  
Controller module, 11  
Customer Service, 97

## D

date and time, 73  
DIN rail, 24, 58, 59, 60, 63  
display panel, 12, 71  
distribution block, 31, 51, 52, 53, 54, 61, 68, 69, 70  
dragging-equipment detectors, 45, 57

## **E**

Equipment menu, 63, 87, 88, 89  
Ethernet, 21, 22, 44, 59  
external radio, 26

## **F**

float voltage, 30, 68, 70, 96  
Functions menu, 73, 76, 82, 83, 84, 85  
fuse block, 31, 51, 52, 69, 70  
fuses, 10, 30, 31, 51, 70, 96

## **G**

gating transducers, 55, 56, 86, 90, 91  
ground rod, 44, 47  
grounding system, 47, 67

## **H**

heaters, 10, 11, 24, 25, 27  
High Load, 63  
high-load detector, 63

## **L**

Last Train, 90

## **M**

Main menu, 59, 72, 73, 76, 78, 80, 82, 83, 84, 85, 87, 88, 89, 90, 91  
maintenance, 6, 11, 41  
modem, 18, 20, 22, 59, 72, 75  
mounting plate, 65, 66, 91, 92  
MPRR, 37, 39  
Multimeter, 46  
multiplexed, 35

## **N**

Network Menu, 16

## **O**

OLED display, 13  
optics, 73, 78, 79, 96

## **P**

password, 88  
power subsystem, 29, 48, 52  
power switch, 26  
presence detector, 22, 81  
Processor board, 11, 17, 24, 26, 35, 37, 71  
PTT, 25, 26  
pyrometer, 15, 74, 76

## **R**

radio, 61  
radio antenna, 61  
Radio Inhibit, 83, 84, 85  
Radio Menu, 16  
Radio Test, 15, 82  
rebroadcast, 26  
relay panel, 11, 24  
RF transceivers, 24  
RFID, 35, 37

## **S**

scanner cover, 78, 79, 80  
serial interface, 72, 73, 76, 78, 80, 82, 83, 84, 85, 87, 89  
serial port, 22  
Setup menu, 88, 89  
shutters, 10, 11, 24, 27, 72, 73, 77, 78, 79, 90  
sleepers, 41  
SOTC board, 10  
speaker, 10, 48, 82, 83, 84, 95  
SRAM, 17  
standard warranty, 5  
status LEDs, 21, 27  
surge-suppression panel, 23, 31, 49, 56, 57, 58  
System Alarms, 17, 90  
System Functions menu, 82, 84  
system health menu, 13  
system parameters, 89  
System-Interconnect board, 9, 10, 18, 25, 26, 33, 56, 57, 58, 63

## **T**

TELCO, 59  
temperature probe, 10, 17, 23, 33, 59, 60, 66, 69  
Test Tone, 82  
test train, 85, 86  
tie plates, 41  
TO1, 23, 55, 56, 57, 86, 91, 93, 95  
TO2, 23, 55, 56, 57, 86, 91, 93, 95  
Train Detail, 17, 35, 37, 91  
Train Summary, 17, 35, 37, 91, 93, 96  
Trains directory, 17, 91  
transducer gain, 87  
transducer loading, 93, 95

## **U**

UTBs, 23, 56, 57, 60

## **V**

varistors, 50, 53  
velocity modem, 20  
Vocabulary Test, 84  
Volume Menu, 16

## **W**

wayside enclosure, 33, 41, 43, 44, 45, 46, 47, 58, 59, 60, 61, 66, 67, 87  
wheel scanners, 10, 42, 55, 74, 79, 80

## **Z**

Zepic III, 22, 81