

Description:

The Model 2300-547 Frauscher Signal Converter Kit consists of DIN mount components designed to provide necessary circuitry to interface the Frauscher RSR110 sensor to a SmartScanNG² detector system. Components include the Frauscher WSC003 Signal Converter (WSC), two UTBs, and various terminal blocks. The assembly is prewired and ready to install.

NOTE:

The 2300-547 Frauscher Signal Converter Kit is a supplemental accessory designed for use with early model SmartScanNG² detectors. It is applicable **ONLY** for those systems equipped with SICM Board Version 1.2 or older. Newer designs have the Frauscher interface circuitry built-in and are easily identified by a "Compatible with Frauscher Wheel Sensors" label on the cover.

WIRING FOR 2300-547 FRAUSCHER SIGNAL CONVERTER KIT

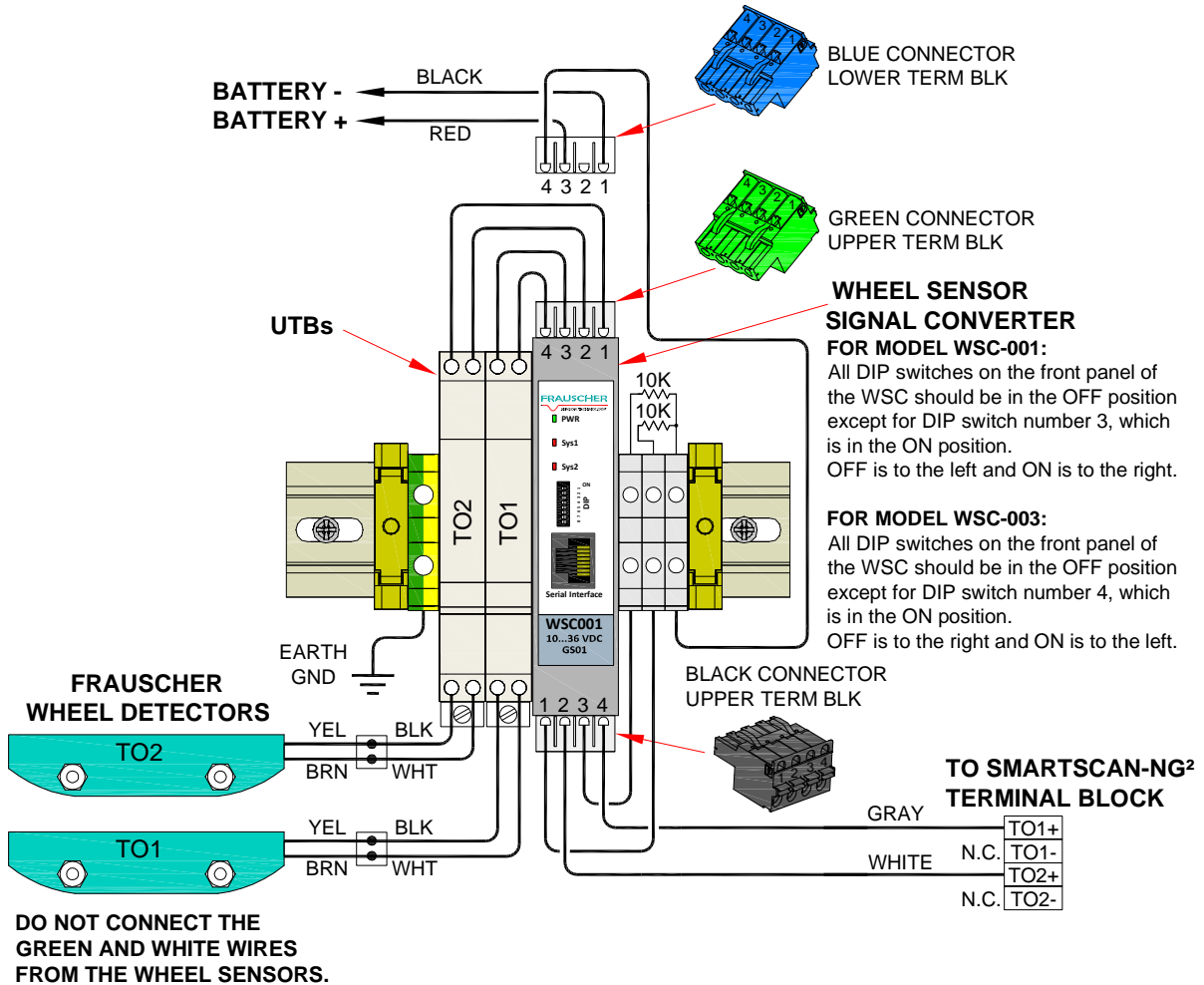

NOTE: This supplemental kit is applicable **ONLY** for those SmartScanNG² systems equipped with SICM Board Version 1.2 or older. Newer designs have the Frauscher interface circuitry built-in and are easily identified by a **Compatible with Frauscher Wheel Sensors** label on the cover.

General Specifications:

Dimensions	4.75" x 5.00" x 4.50"
Weight	0.75 lbs
Temperature Spec. - Industrial	-40°C to +70°C
RoHS Compliant	No