

# Multiprotocol Rail Reader System Guide

---



TransCore  
8600 Jefferson Street NE  
Albuquerque, New Mexico 87113

April 2011

P/N 412123

## ***Multiprotocol Rail Reader System Guide***

Information in this document is subject to change and does not represent a commitment on the part of TC License, Ltd.

© 2010 TC License, Ltd. All rights reserved. TRANSCORE, AMTECH, and EGO are registered trademarks and TRU is a trademark of TC License, Ltd. All other trademarks listed are the property of their respective owners. Contents are subject to change. Printed in the U.S.A.

For further information, contact:

TransCore  
3410 Midcourt Road, Suite 102  
Carrollton, Texas 75006 USA

Phone: (214) 461-4031  
Fax: (214) 461-6478

Technical Support  
Phone: (214) 461-6449  
Web: [transcore.com/rfidsupport](http://transcore.com/rfidsupport)

For comments or questions about this document, e-mail [tech.pubs@transcore.com](mailto:tech.pubs@transcore.com).

**WARNING TO USERS IN THE UNITED STATES**

**FEDERAL COMMUNICATIONS COMMISSION (FCC)  
LOCATION AND MONITORING SERVICE STATEMENT  
47 CFR §90.351**

**NOTE:** The user is required to obtain a Part 90 site license from the FCC to operate this radio frequency identification (RFID) device in the United States. The FCC ID number is FIH05716. Access the FCC Web site at [www.fcc.gov/Forms/Form601/601.html](http://www.fcc.gov/Forms/Form601/601.html) or at [wireless.fcc.gov/index.htm?job=online\\_filing](http://wireless.fcc.gov/index.htm?job=online_filing) to obtain additional information concerning licensing requirements.

**NOTE:** Users in all countries should check with the appropriate local authorities for licensing requirements.

**FCC RADIO FREQUENCY INTERFERENCE STATEMENT  
47 CFR §15.105(a)**

**NOTE:** This equipment has been tested and found to comply with the limits for a Class A digital device pursuant to Part 15 of the FCC rules. These limits are designed to provide reasonable protection against harmful interference when the equipment is operated in a commercial environment. This equipment generates, uses, and can radiate RF energy and may cause harmful interference to radio communications if not installed and used in accordance with the instruction manual. Operating this equipment in a residential area is likely to cause harmful interference, in which case, depending on the laws in effect, the user may be required to correct the interference at their own expense.

**NO UNAUTHORIZED MODIFICATIONS  
47 CFR §15.21**

**CAUTION:** This equipment may not be modified, altered, or changed in any way without permission from TransCore, LP. Unauthorized modification may void the equipment authorization from the FCC and will void the TransCore warranty.

**USE OF SHIELDED CABLES IS REQUIRED  
47 CFR §15.27(a)**

**NOTE:** Shielded cables must be used with this equipment to comply with FCC regulations.

**TransCore, LP  
USA**

## Health Limits for Multiprotocol Rail Reader Using External Antenna (902 to 928 MHz)

---

Within the United States, environmental guidelines regulating safe exposure levels are issued by the Occupational Safety and Health Administration (OSHA).

Section 1910.97 of OSHA Safety and Health Standards 2206 legislates a maximum safe exposure limit of 10 milliwatts per square centimeter ( $\text{mW}/\text{cm}^2$ ) averaged over 6 minutes at 902 MHz.

Although not binding, other organizations such as the American National Standards Institute (ANSI) have issued similar guidelines that are more restrictive than the OSHA limits (ANSI C95.1). ANSI guidelines recommend a maximum safe power density in  $\text{mW}/\text{cm}^2$  of:

**Frequency (in MHz)**  
**1500**

Thus, the maximum permissible exposure for general population/uncontrolled exposure at 902 MHz is  $0.60 \text{ mW}/\text{cm}^2$ . The power limit is a six-minute average.

The RF power density generated by the Multiprotocol Rail Reader (MPRR) was calculated using a maximum antenna gain of 14 dBi, equivalent to the antenna gain of a Universal Toll Antenna.



**Warning**

*At 2 W conducted into the antenna and a distance of 31 inches (78 cm) from the antenna, the maximum power density calculated was less than  $0.60 \text{ mW}/\text{cm}^2$ . Install the antenna at least 31 inches (78 cm) from the general public. Maintenance personnel must remain at least 14 inches (35 cm) from antenna when system is operating.*

The data confirms that the TransCore MPRR effectively meets OSHA requirements and thus does not represent an operating hazard to either the general public or maintenance personnel.

---

# Contents



# Contents

<i>Health Limits for Multiprotocol Rail Reader Using External Antenna (902 to 928 MHz)</i> .....	iv
--	----

## 1 Introduction

---

<i>Purpose</i> .....	1-3
<i>Audience</i> .....	1-3
<i>System Guide Organization</i> .....	1-3
<i>Typographical Conventions</i> .....	1-5
<i>Licensing Requirements</i> .....	1-5
<i>Technical Support</i> .....	1-6

## 2 Developing the Site Plan

---

<i>System Description</i> .....	2-3
<i>Reader</i> .....	2-3
<i>Tags</i> .....	2-4
<i>How It Works</i> .....	2-4
<i>Overview of Site Planning</i> .....	2-4
<i>Reading of Mixed Population Tags</i> .....	2-4
<i>Antenna and Tag Alignment</i> .....	2-5
<i>Polarization</i> .....	2-5
<i>Unobstructed Line of Sight</i> .....	2-6
<i>Antenna Selection</i> .....	2-7
<i>AA3110 Parapanel</i> .....	2-7
<i>AA3140 PCB Log Periodic</i> .....	2-7
<i>Site Layout and Traffic Flow</i> .....	2-8
<i>The MPRR Read Zone</i> .....	2-8
<i>Other MPRRs and Antennas in the Area — AAR-formatted Tag Operation</i> .....	2-8
<i>Reflection, Refraction, and Diffraction of RF Signals</i> .....	2-9
<i>Existing Signal Interference at the Site</i> .....	2-9

<b>Electrical and Communications Requirements</b> .....	<b>2-10</b>
Power and Communications Cables .....	2-10
Electrical Power .....	2-10
Host Communications .....	2-11
Input/Output Circuits .....	2-12
Antenna Interface .....	2-12

### 3 Choosing, Installing, and Removing Tags

---

<b>Compatible Tag Types</b> .....	<b>3-3</b>
Reader and Tag Model Interoperability .....	3-3
<b>Recommended Mounting Locations</b> .....	<b>3-3</b>
Required Materials .....	3-3
Mounting Surface .....	3-4
Tag Positioning .....	3-4
Surface Installation Techniques .....	3-6
Rivet/Bolt Mounting Guidelines .....	3-6
<b>Locomotive Mounting Guidelines</b> .....	<b>3-7</b>
Tag Placement Window Location .....	3-7
Tag Placement .....	3-9
<b>Rail Car Mounting Guidelines</b> .....	<b>3-9</b>
Tag Placement Window Location .....	3-9
Tag Placement .....	3-10
<b>Tank Car Mounting Guidelines</b> .....	<b>3-11</b>
Tag Placement Window Location .....	3-11
Tag Placement .....	3-12

### 4 Installing the Multiprotocol Rail Reader

---

<b>Installation Process</b> .....	<b>4-3</b>
Materials Supplied by TransCore .....	4-3
Contents of Shipping Carton .....	4-3
Installation Accessory Options .....	4-4
Additional Materials Needed for Testing .....	4-4
<b>Pre-installation Testing of the MPRR</b> .....	<b>4-4</b>
Testing the MPRR Using an Audible Circuit Tester .....	4-4
Discharging Voltage from the Antenna .....	4-5
Required Equipment .....	4-5
Connecting the Antenna .....	4-7
Connecting the MPRR to a Power Supply .....	4-8



<b>Mounting the MPRR</b> .....	<b>4-10</b>
<i>Mounting to an Enclosure Wall or Flat Surface</i> .....	4-12
<i>Required Materials</i> .....	4-12
<b>Mounting the Antenna Rail-Side</b> .....	<b>4-12</b>
<b>Connecting the Power Supply</b> .....	<b>4-12</b>
<b>Connecting Communications</b> .....	<b>4-12</b>
<i>Required Materials</i> .....	4-13
<i>Connecting the MPRR to the Host</i> .....	4-13
<b>Connecting Sense Input and Sense Output Circuits</b> .....	<b>4-13</b>
<i>Sense Input Circuits</i> .....	4-13
<i>Sense Output Circuit</i> .....	4-14
<b>Marking the Read Zone</b> .....	<b>4-14</b>
<i>Required Materials</i> .....	4-14

## 5 General Software Information

---

<b>Command Entry Conventions</b> .....	<b>5-3</b>
<b>Command Response Conventions</b> .....	<b>5-4</b>
<b>Operating Parameters</b> .....	<b>5-4</b>
<b>Power Fail</b> .....	<b>5-5</b>
<b>Program Download</b> .....	<b>5-5</b>
<i>Download Considerations</i> .....	5-5
<i>Download Procedures</i> .....	5-5
<b>Startup</b> .....	<b>5-5</b>
<i>Sign-On Message</i> .....	5-6
<i>Boot Failure Message</i> .....	5-6
<b>Tag/Message Buffer</b> .....	<b>5-6</b>

## 6 Communications Protocols

---

<b>Introduction</b> .....	<b>6-3</b>
<b>Basic Protocol</b> .....	<b>6-4</b>
<b>Error Correcting Protocol</b> .....	<b>6-4</b>
<b>Data Inquiry Protocol</b> .....	<b>6-5</b>

<b>Basic Protocol and ECP Format</b> .....	<b>6-5</b>
Reader Transmissions .....	6-5
ECP Host ACK/NAK Response .....	6-6
Switch to Command Mode Request .....	6-7
Host Transmission .....	6-7
Reader Command Response .....	6-8
Sample Messages .....	6-9
Reader Transmissions .....	6-9
Host Command Transmissions .....	6-10
Timing and Synchronization .....	6-11
Reader-Addressed Failure Conditions .....	6-12
Illegal Sequence Number (not in the range 0–9, A–F) .....	6-12
Wrong Sequence Number .....	6-12
Incorrect CRC .....	6-12
Illegal Command .....	6-12
Transmission Timeout .....	6-12
Receive Timeout .....	6-13
Asynchronous Message/Command Message Collision .....	6-13
Host-Addressed Failure Conditions .....	6-13
Illegal or Wrong Sequence Number .....	6-13
Incorrect CRC .....	6-13
Transmission Timeout .....	6-13
Receive Timeout .....	6-13
Asynchronous Message/Command Message Collision .....	6-13
<b>ECP Reliability</b> .....	<b>6-13</b>
<b>CRC Calculation</b> .....	<b>6-14</b>
<b>Manually Disabling ECP for Maintenance</b> .....	<b>6-17</b>

## 7 Commands

---

<b>Introduction</b> .....	<b>7-3</b>
<b>Operating Modes</b> .....	<b>7-3</b>
Data Mode .....	7-3
Command Mode .....	7-4
Download Mode .....	7-5
<b>Command List</b> .....	<b>7-5</b>
Reader Mode Control — Command Group 0 .....	7-5
00 Switch to Data Mode (Factory Default) .....	7-5
01 Switch to Command Mode .....	7-7
Communications Port Control — Command Group 1 .....	7-7
100N Select Baud Rate .....	7-7
101N Select Stop Bits .....	7-7
102N Select Parity .....	7-8
Command Group 2 .....	7-8
20 Set Time .....	7-8

21 Set Date . . . . .	7-9
22 Display Time and Date . . . . .	7-9
Append Information — Command Group 3 . . . . .	7-10
30N Append Time and Date Selection . . . . .	7-10
31N Append Auxiliary Information Selection . . . . .	7-10
ID Filtering — Command Group 4 . . . . .	7-11
40 Transmit All ID Codes . . . . .	7-11
410N Select Unique ID Code Criteria (Anti-passback Feature) . . . . .	7-12
420N Select Valid ID Code Criteria . . . . .	7-13
440 Reset Uniqueness . . . . .	7-13
44N Set Uniqueness Timeout . . . . .	7-13
452 Disable Tag Translation Mode (Factory Default) . . . . .	7-14
453 Enable Tag Translation Mode . . . . .	7-14
456 Enable SeGo Protocol Tag Initialization During Multi-tag Sort (Factory Default) . . . . .	7-14
457 Disable SeGo Protocol Tag Initialization During Multi-tag Sort . . . . .	7-14
480 Disable ATA . . . . .	7-14
481 Enable ATA . . . . .	7-15
484 Disable SeGo . . . . .	7-15
485 Enable SeGo . . . . .	7-15
488 Disable eATA . . . . .	7-15
489 Enable eATA . . . . .	7-15
Reader Status — Command Group 5 . . . . .	7-15
505 Display Software Version . . . . .	7-15
506 Display Hardware Configuration Information . . . . .	7-15
520 Display Power Fail Bit . . . . .	7-16
521 Display Reader ID Number . . . . .	7-16
522 Display Communications Port Parameters . . . . .	7-16
524 Display Appended Information Status . . . . .	7-17
525 Display Communications Protocol Status . . . . .	7-17
527 Display RF Status . . . . .	7-18
529 Display Presence Input Status . . . . .	7-19
530 Display RF0 Filter Status . . . . .	7-21
534 Display Tag Translation Mode Status . . . . .	7-21
537 Display Echo Status . . . . .	7-22
540 Display Flash Checksum . . . . .	7-22
543 Display Boot Checksum . . . . .	7-22
549 Get User-Programmable Group Select Equals (GSE) Filter Data . . . . .	7-22
552 Display Antenna Multiplexing Mode . . . . .	7-23
560 Request Sensor Status Change . . . . .	7-23
570 Display Operating Mode Status . . . . .	7-23
577 Report Buffered Handshakes . . . . .	7-24
Reader Control Functions — Command Group 6 . . . . .	7-24
60NN Set Reader ID Number . . . . .	7-24
610 Select Basic Communication Protocol (Factory Default) . . . . .	7-24
611 Select Error Correcting Protocol . . . . .	7-24
612NN Select Error Correcting Protocol Timeout . . . . .	7-25
613 Enable Data Inquiry Protocol . . . . .	7-25

614N Select Flow Control Option . . . . .	7-25
6170 Disable Echo Mode . . . . .	7-26
6171 Enable Echo Mode (Factory Default). . . . .	7-26
63 Reset Reader. . . . .	7-26
640N RF Control. . . . .	7-27
641 Select RF-by-Input Control (Factory Default) . . . . .	7-27
643NN Select ATA Operating Range (Distance) . . . . .	7-27
644NN Set RF Attenuation . . . . .	7-28
645NN Set SeGo Protocol Operating Range (Distance) . . . . .	7-28
647XXX Select RF Operating Frequency. . . . .	7-29
65 Reset Power Fail Bit . . . . .	7-30
66F Load Default Operating Parameters . . . . .	7-30
690N Select Presence Without Tag Report Option . . . . .	7-30
692N Select RF Control Algorithm . . . . .	7-31
693N Select RF Timeout Period. . . . .	7-31
694N Select Input Inversion Option . . . . .	7-32
695S...S Set Serial Number (Factory Default) . . . . .	7-33
696S...S Store Hardware Configuration String (Factory Default). . . . .	7-33
697 Set User-Programmable Group Select Equals (GSE) Filter . . . . .	7-34
Auxiliary Reader Control — Command Group 8. . . . .	7-35
8110 Switch on RF Port 0, Fire Off Check Tag Address 0 on Check Tag Pin 0	7-35
8111 Switch on RF Port 1, Fire Off Check Tag Address 1 on Check Tag Pin 0	7-35
8112 Switch on RF Port 2, Fire Off Check Tag Address 0 on Check Tag Pin 1	7-35
8113 Switch on RF Port 3, Fire Off Check Tag Address 1 on Check Tag Pin 1	7-35
8142X Set Check Tag Character on Check Tag Pin 0. . . . .	7-35
8143X Set Check Tag Character on Check Tag Pin 1. . . . .	7-35
8150 Set Check Tag Address to 0 on Check Tag Pin 0. . . . .	7-35
8151 Set Check Tag Address to 1 on Check Tag Pin 0. . . . .	7-35
8152 Set Check Tag Address to 0 on Check Tag Pin 1. . . . .	7-35
8153 Set Check Tag Address to 1 on Check Tag Pin 1. . . . .	7-35
830 Disable Automatic Periodic RF Status Report (Factory Default) . . . . .	7-36
831 Enable Automatic Periodic RF Status Report . . . . .	7-36
836 Disable MPRR Mode . . . . .	7-36
837 Enable MPRR Mode . . . . .	7-36
850 MUX RF Port 0 (Factory Default). . . . .	7-36
851 MUX Between RF Ports 0 and 1 . . . . .	7-36
852 MUX Between RF Ports 0, 1, and 2. . . . .	7-37
853 MUX Between RF Ports 0, 1, 2, and 3. . . . .	7-37
891 MUX Test Mode RF Port 1 Only . . . . .	7-37
892 MUX Test Mode RF Port 2 Only . . . . .	7-37
893 MUX Test Mode RF Port 3 Only . . . . .	7-37
Check Tag Operation . . . . .	7-37
MUX Operational Modes . . . . .	7-38
MUX Test Modes. . . . .	7-38

## **8 Configuring the Multiprotocol Rail Reader**

---

<b>Configuring the Reader . . . . .</b>	<b>8-3</b>
Default Operating Parameter Settings . . . . .	8-3

<b>Configuring Parameters with Terminal Emulation Software</b> .....	<b>8-4</b>
Starting the Terminal Emulation Software .....	8-4
Verifying Communications .....	8-7
Verifying Tag Read Capability .....	8-9
<b>Configuring MPRR Parameters</b> .....	<b>8-12</b>
Appended Tag Data .....	8-12
ID Separation .....	8-12
Reports .....	8-13
Reset Reader .....	8-13
Radio Frequency .....	8-14
RF Transmission .....	8-14
Presence Detector Controlling RF Transmission .....	8-15
Host Controlling RF Transmission .....	8-15
Sense Inputs .....	8-15
Sense Output Device .....	8-16
Serial Port Communications .....	8-16
Port Configuration Parameters .....	8-17
Communications Protocol .....	8-17
Software Flow Control .....	8-17
Fine-Tuning and Verifying the Read Zone .....	8-18
Physically Orienting the MPRR Antenna(s) .....	8-18
Fine-Tuning the Read Zone by Lowering Output Power .....	8-18
Fine-tuning the Read Zone by Adjusting Sensitivity Range .....	8-19

## 9 Troubleshooting and Maintenance

---

<b>Error Messages</b> .....	<b>9-3</b>
<b>Troubleshooting</b> .....	<b>9-4</b>
<b>MPRR Repair</b> .....	<b>9-6</b>
<b>Technical Support</b> .....	<b>9-6</b>
<b>Marketing Support</b> .....	<b>9-6</b>

## 10 Interface to Train Recording Unit

---

<b>TRU System Overview</b> .....	<b>10-3</b>
<b>MPRR to TRU Connection</b> .....	<b>10-5</b>

## 11 AT5270 Check Tag-to-MPRR Assembly

---

<b>Required Supplies</b> .....	<b>11-3</b>
<b>Procedures</b> .....	<b>11-3</b>

## A Glossary

---

## B Technical Specifications

---

<b>Reader Specifications</b> .....	<b>B-3</b>
Communications .....	B-3
Hardware Features .....	B-3
Power Requirements .....	B-3
Physical Attributes .....	B-3
Environmental Parameters .....	B-4
Options .....	B-4

## C Wiring Information

---

<b>Communications Interfaces</b> .....	<b>C-3</b>
--	------------

## D Command Quick Reference

---

<b>Command Syntax</b> .....	<b>D-3</b>
<b>Factory Default Settings</b> .....	<b>D-3</b>
<b>Numerical Command List</b> .....	<b>D-4</b>
<b>Alphabetical Command List</b> .....	<b>D-15</b>

## E Compatible Tag Information

---

<b>Tag Configurations</b> .....	<b>E-3</b>
Tag Data Formats .....	E-4

## Index

---

## List of Figures

---

<b>Figure 2-1 MPRR End Views</b> . . . . .	2-3
<b>Figure 2-2 Tag and Antenna Orientation (horizontal polarization)</b> . . . . .	2-5
<b>Figure 2-3 Horizontally Polarized Tag</b> . . . . .	2-6
<b>Figure 2-4 Antenna Location Relative to Tag Position</b> . . . . .	2-7
<b>Figure 2-5 Location of Communications/Power Port on MPRR</b> . . . . .	2-11
<b>Figure 2-6 Pin Assignments for Communications Connectors</b> . . . . .	2-12
<b>Figure 3-1 Clear Zone - Side View</b> . . . . .	3-5
<b>Figure 3-2 Clear Zone - End View</b> . . . . .	3-5
<b>Figure 3-3 Mounting Location Examples</b> . . . . .	3-6
<b>Figure 3-4 Tag Placement Window for Locomotives -- Right Front</b> . . . . .	3-7
<b>Figure 3-5 Right Front Placement of Tag on Locomotive</b> . . . . .	3-8
<b>Figure 3-6 Tag Placement Window Location for Locomotives — Left Rear</b> . . . . .	3-8
<b>Figure 3-7 Optimal Tag Placement for Locomotives</b> . . . . .	3-9
<b>Figure 3-8 Tag Placement Window Location for Rail Cars -- “A” Right Side</b> . . . . .	3-10
<b>Figure 3-9 Tag Placement Window Location for Rail Cars -- “B” Left Side</b> . . . . .	3-10
<b>Figure 3-10 Optimal Tag Placement for Rail Cars</b> . . . . .	3-11
<b>Figure 3-11 Tag Placement Window Location for Tank Cars -- “B” Left Side</b> . . . . .	3-12
<b>Figure 3-12 Optimal Tag Placement for Tank Cars</b> . . . . .	3-12
<b>Figure 4-1 Wiring for Audible Circuit Tester</b> . . . . .	4-5
<b>Figure 4-2 Connect RF N-type Load or Attenuator to Reader Cable End</b> . . . . .	4-6
<b>Figure 4-3 Short Load to Earth Ground</b> . . . . .	4-6
<b>Figure 4-4 MPRR Showing Antenna Ports</b> . . . . .	4-7
<b>Figure 4-5 Location of MPRR Ground Stud</b> . . . . .	4-8
<b>Figure 4-6 Location of Communications/Power Port on MPRR</b> . . . . .	4-9
<b>Figure 4-7 Pin Assignments for Signal to Host Connectors</b> . . . . .	4-9
<b>Figure 4-8 MPRR Outer Dimensions and Mounting Hole Locations</b> . . . . .	4-11
<b>Figure 4-9 Sample Read Zone Marking Pattern</b> . . . . .	4-16
<b>Figure 8-1 Connection Description Dialog Box</b> . . . . .	8-5
<b>Figure 8-2 Phone Number Dialog Box</b> . . . . .	8-5
<b>Figure 8-3 COM 1 Properties Dialog Box</b> . . . . .	8-6
<b>Figure 8-4 Hyper Terminal Main Screen</b> . . . . .	8-7
<b>Figure 8-5 Sign-on Message</b> . . . . .	8-8
<b>Figure 8-6 Tag and Antenna Orientation (horizontal polarization)</b> . . . . .	8-10
<b>Figure 8-7 Successful Tag Read</b> . . . . .	8-11
<b>Figure 8-8 Second Successful Tag Read</b> . . . . .	8-11
<b>Figure 8-9 MPRR RF Control Options</b> . . . . .	8-15
<b>Figure 10-1 TRU Front Panel Showing Operational LEDs</b> . . . . .	10-4
<b>Figure 10-2 TRU-MPRR Communications Interface Cable Port (bottom of TRU)</b> . . . . .	10-5
<b>Figure 10-3 MPRR-TRU Communications Interface Cable</b> . . . . .	10-6
<b>Figure 11-1 Place Nut and Grommet Over Exposed Check Tag Wires</b> . . . . .	11-4
<b>Figure 11-2 Feed Check Tag Wires through Plastic Housing Connector</b> . . . . .	11-4
<b>Figure 11-3 Connect Check Tag Wires</b> . . . . .	11-4
<b>Figure 11-4 Two Check Tag Assemblies Connected to Terminal Strip</b> . . . . .	11-5
<b>Figure 11-5 Securing Terminal Strip into Connector Housing</b> . . . . .	11-5
<b>Figure 11-6 Plastic Nuts with Grommets</b> . . . . .	11-6
<b>Figure 11-7 Nylon Cap Securely Fastened in Unused Port</b> . . . . .	11-6
<b>Figure 11-8 Check Tag Assembly Secured to MPRR Port (single check tag assembly shown)</b> . . . . .	11-7





## List of Tables

---

<b>Table 2-1 Examples of Staggered Reader Frequencies for AAR-formatted Tag Operation</b>	<b>2-9</b>
<b>Table 2-2 Connector Cabling Accessory Kits</b>	<b>2-10</b>
<b>Table 2-3 Power Supply Current Requirements</b>	<b>2-11</b>
<b>Table 2-4 Reader to Antenna Cable Performance</b>	<b>2-13</b>
<b>Table 3-1 Tags Read by the MPRR</b>	<b>3-3</b>
<b>Table 4-1 Installation Accessories</b>	<b>4-4</b>
<b>Table 4-2 MPRR-to-Host Communications Cable Pin Designations</b>	<b>4-9</b>
<b>Table 4-3 Commands for Testing RF Port-0</b>	<b>4-15</b>
<b>Table 4-4 Commands for Testing RF PORT-1</b>	<b>4-17</b>
<b>Table 4-5 Commands for Testing RF PORT-2</b>	<b>4-17</b>
<b>Table 4-6 Commands for Testing RF PORT-3</b>	<b>4-17</b>
<b>Table 5-1 Four-Character Command Structure</b>	<b>5-3</b>
<b>Table 5-2 Sample Command Sequence</b>	<b>5-4</b>
<b>Table 7-1 Select Baud Rate Commands</b>	<b>7-7</b>
<b>Table 7-2 Select Stop Bits Commands</b>	<b>7-8</b>
<b>Table 7-3 Select Parity Commands</b>	<b>7-8</b>
<b>Table 7-4 Append Time and Date Commands</b>	<b>7-10</b>
<b>Table 7-5 Append Auxiliary Information Commands</b>	<b>7-11</b>
<b>Table 7-6 Unique ID Code Criteria</b>	<b>7-12</b>
<b>Table 7-7 Select Valid Code Commands and Frames</b>	<b>7-13</b>
<b>Table 7-8 Flow Control Commands</b>	<b>7-26</b>
<b>Table 7-9 RF Control Commands</b>	<b>7-27</b>
<b>Table 7-10 RF Attenuation Command Variables</b>	<b>7-28</b>
<b>Table 7-11 Select RF Frequency Commands</b>	<b>7-29</b>
<b>Table 7-12 Presence Without Tag Report Commands</b>	<b>7-31</b>
<b>Table 7-13 RF Control Algorithm Commands</b>	<b>7-31</b>
<b>Table 7-14 Timeout Period Values</b>	<b>7-32</b>
<b>Table 7-15 Input Inversion Options</b>	<b>7-33</b>
<b>Table 8-1 MPRR Default Configuration Settings</b>	<b>8-3</b>
<b>Table 8-2 Command Sequence to Verify Communications</b>	<b>8-9</b>
<b>Table 9-1 Error Messages</b>	<b>9-3</b>
<b>Table 9-2 Symptoms and Remedies</b>	<b>9-4</b>
<b>Table 10-1 MPRR-to-TRU Interface Cable Pin and Signal Designations</b>	<b>10-6</b>
<b>Table 11-1 Check Tag Kit Parts List</b>	<b>11-3</b>
<b>Table 11-2 Check Tag 0 Wire Assignments</b>	<b>11-4</b>
<b>Table 11-3 Check Tag 1 Wire Assignments</b>	<b>11-5</b>



---

## Introduction



# Chapter 1

---

## Introduction

***This chapter is the introduction to this manual and provides information pertaining to the audience, organization, document conventions, system description, and license information for the Multiprotocol Rail Reader System.***

### ***Purpose***

---

This guide provides site planning and testing, installing, and operating instructions for TransCore's Multiprotocol Rail Reader (MPRR) System, which reads Association of American Railroads (AAR) formatted tags and TransCore Super eGo<sup>®</sup> (SeGo) protocol tags. Before you begin installing the MPRR, TransCore recommends that you familiarize yourself with this manual.

### ***Audience***

---

This document is intended to be used by authorized TransCore MPRR dealers, installers, and service personnel. Because the MPRR has no operator- or end-user serviceable components or features, no end-user manual or operator guide exists. Once the system is set up and tested by the *authorized* installer, MPRR operation requires no end-user intervention.

### ***System Guide Organization***

---

The chapters of this guide and a description of the contents are listed below.

- Chapter 1, "Introduction," explains the purpose and describes the audience for the guide, outlines the manual's organization, provides a brief description of the MPRR, and discusses Federal Communications Commission (FCC) licensing requirements.
- Chapter 2, "Developing the Site Plan," discusses factors to be considered when developing the site plan and before ordering equipment and installing the MPRR. These considerations include antenna and tag alignment, site layout and traffic flow, and electrical and communications requirements.
- Chapter 3, "Choosing, Installing, and Removing Tags," contains information on compatible tag models and provides procedures for installing tags onto, and removing tags from, railcars where the MPRR is installed.

## ***Multiprotocol Rail Reader System Guide***



- Chapter 4, “Installing the Multiprotocol Rail Reader,” lists the materials needed and provides procedures to install the MPRR. Steps include:
  - Pre-installation testing
  - Installing the MPRR in a raiiside hut or NEMA enclosure
  - Connecting power and communications
  - Connecting to TransCore’s Train Recording Unit (TRU™)
  - Marking the read zone
- Chapter 5, “General Software Information,” and Chapter 6, “Communications Protocols,” provide reference information on various software-related topics and communications protocols.
- Chapter 7, “Commands,” discusses the host-transmitted commands that are used to control MPRR configuration and operation.
- Chapter 8, “Configuring the Multiprotocol Rail Reader,” provides procedures for configuring and fine-tuning the MPRR after installing it at the site.
  - Marking the read zone
- Chapter 9, “Troubleshooting and Maintenance,” answers the most commonly asked questions about installing and maintaining the MPRR.
- Chapter 10, “Interface to Train Recording Unit,” describes the interoperability between the MPRR and the TRU.
- Chapter 11, “Connecting AT5720 Check Tag-to-MPRR Assembly,” explains how to connect one or two check tags to the MPRR.
- Appendix A, “Glossary,” contains frequently used terms.
- Appendix B, “Technical Specifications,” provides the MPRR specifications.
- Appendix C, “Wiring Information,” shows the wiring connections for the communications interfaces, electrical cable connections, and the external interface signal wiring.
- Appendix D, “Command Quick Reference,” lists the MPRR factory default configuration settings and provides host software commands in numerical and alphabetical order.
- Appendix E, “Compatible Tag Information,” provides helpful information about tags that are compatible with the MPRR.
- Index provides an alphabetical listing of guide topics.

## Typographical Conventions

---

The conventions listed in [Table 1-1](#) are used in this manual.

**Table 1-1** *Typographical Conventions*

Convention	Indication
	Concerns about a procedure.
Code	Code, including keywords and variables within text and as separate paragraphs, and user-defined program elements within text appear in courier typeface.
<b>Dialog Box Title</b>	Title of a dialog box as it appears on screen.
<b>Menu Item</b>	Appears on a menu. Capitalization follows the interface.
<i>Note</i>	Auxiliary information that further clarifies the current discussion. These important points require the user's attention. The paragraph is in italics and the word Note is bold.
NUL	Zero-value ASCII character or a zero-value byte.
NULL	Zero-value pointers. Null-terminated string refers to strings of printable ASCII characters with a zero-value byte placed in memory directly after the last printable character of the string.
	This procedure might cause harm to the equipment and/or the user.

## Licensing Requirements

---

An FCC license provides the user with the legal authorization to operate the MPRR on the licensed frequencies at the site specified in the license. Only an authorized installer or service technician can set the RF frequency of the MPRR to the frequency specified in the FCC site license. No end-user-operated controls exist on the MPRR.

The FCC license may provide the user with protection and authorization to maintain the system should any other RFID product be used in the licensed area after the MPRR equipment is installed.

Users of the MPRR in the United States must obtain a license from the FCC. In the United States, the authorized *modulated* (SeGo protocol operation) frequency band for

this product is 911.75 to 919.75 MHz and the authorized *continuous wave* (AAR-formatted operation) frequency band is 902.25 to 903.75 MHz and 910.00 to 921.50 MHz.

The user is responsible for filing the FCC license according to FCC regulations, but the TransCore dealer will provide assistance and support as necessary to complete these forms. Forms are available online at the FCC internet site <http://wireless.fcc.gov/uls>. For further information on obtaining the license contact TransCore.

## ***Technical Support***

---

Authorized dealers and distributors are responsible for the direct support of all customers. Authorized dealers and distributors needing technical support can contact:

Technical Support

Phone: (214) 461-6449

Web: [transcore.com/rfidsupport](http://transcore.com/rfidsupport)

or

TransCore

3410 Midcourt Road, Suite 102

Carrollton, Texas 75006 USA

Phone: (214) 461-4031

Fax: (214) 461-6478

Please be prepared to answer a series of questions that are designed to direct you to the best support resource available.



# 2

---

## Developing the Site Plan



# Developing the Site Plan

*This chapter provides a brief description of the Multiprotocol Rail Reader (MPRR) and discusses site plan development for installing the MPRR System.*

## System Description

The MPRR is a reader that supports Association of American Railroads (AAR) formatted tags and TransCore's low-cost, high-performance Super eGo<sup>®</sup> (SeGo) radio frequency identification (RFID) technology.

The MPRR is a high-power unit that reads full frame tags. The reader output power can be adjusted using reader commands.

The MPRR can multiplex up to four antennas, which allows a single reader to be used for two tracks. The MPRR can support up to two AT5720 Check Tags.

## Reader

The MPRR consists of an input/output (I/O) module, a power supply, a reader logic board (also called a tag decoder), and a radio frequency (RF) transmitter/receiver (called the RF module) in a compact enclosure. These MPRR components are contained in a highly reliable, compact, and easy-to-install package. Figure 2-1 shows the the communications/power connector, check tag connector, and antenna ports locations on opposite ends of the MPRR.

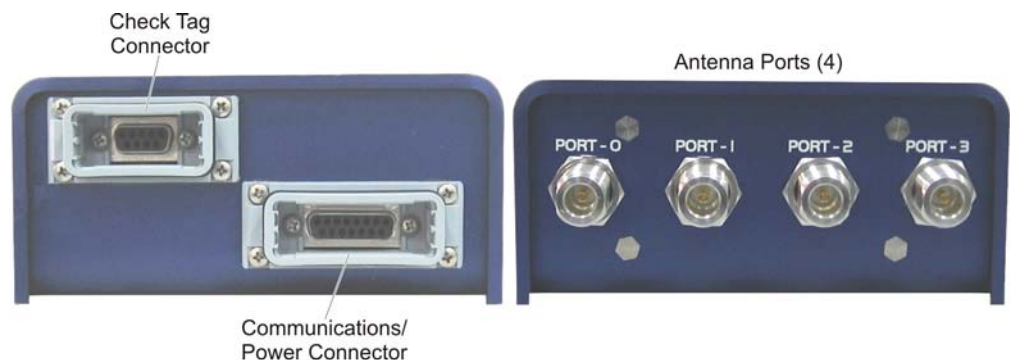

HW-0420

**Figure 2-1 MPRR End Views**

---

## **Tags**

The MPRR has the capability to read TransCore AAR formatted read-only full frame tags and TransCore SeGo protocol tags, for example, the AT5118 Harsh Environment Transportation Tag.

---

## **How It Works**

The MPRR directs the RF module to generate an RF signal, which is broadcast through the external antenna mounted raily. Entering the MPRR's reading range, a TransCore RFID tag installed on a railcar or other asset to be tracked adds its programmed identification information to the signal and reflects the signal back to the MPRR. The MPRR receives this modified, or modulated signal, and decodes the tag data carried by the reflected signal and transmits this data to the Train Recording Unit (TRU) or local host computer for processing.

---

## **Overview of Site Planning**

Developing a site plan provides the foundation for the site's system design and establishes the following system configuration parameters:

- Number and general location of primary components
- Number of different radio frequencies required

Gathering relevant site information is crucial before applying for Federal Communications Commission (FCC) approval and ordering and installing MPRR(s) and tags.

Also, consider the following factors when developing a site plan:

- Type of tags used
- Antenna and tag alignment
- Site layout and rail traffic flow
- MPRR and/or antenna mounting requirements
- MPRR electrical requirements
- MPRR communications requirements

These factors provide relevant information regarding each site's physical and electromagnetic environment and the conditions under which the system must perform.

---

## **Reading of Mixed Population Tags**

The MPRR reads AAR-formatted tags and TransCore's SeGo protocol tags. The factors that influence the readability include, but are not limited to, physical orientation and configuration, type of read-only tag, ratio of backscatter cross-section of the tags, and whether the tag is battery powered or beam powered.

## Antenna and Tag Alignment

---

The position of the antenna and placement of the tag on the vehicle must be compatible.

Two primary criteria must be satisfied to achieve the highest read reliability:

- Tag and the antenna polarization, they must be aligned in the same direction — both horizontal.
- The installed tag must be in a direct, unobstructed line of sight to the antenna.



### Caution

*A tag may not be reliably read unless the preceding criteria are met.*

---

### Polarization

The polarization of the tag must be aligned in the same direction as the antenna. [Figure 2-2](#) shows horizontally polarized antenna and tag.

*Note: Matching the tag and antenna polarization is critical to obtain optimal system performance.*

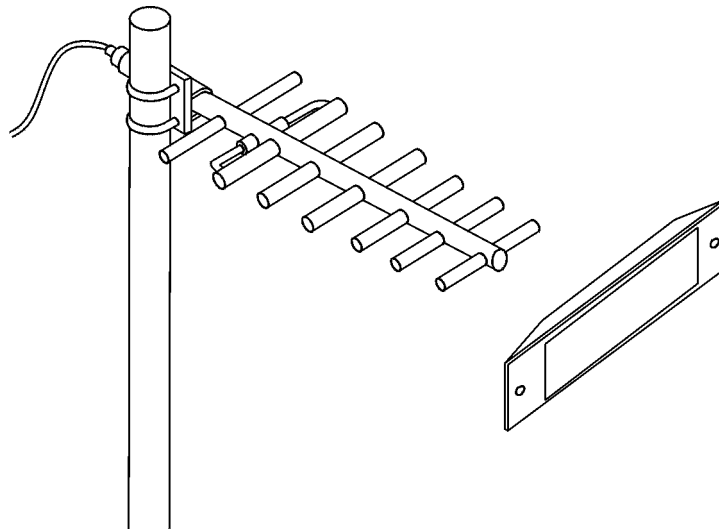

TA-0016

**Figure 2-2 Tag and Antenna Orientation (horizontal polarization)**

Figure 2-3 shows a tag in correct polarization for the antenna.

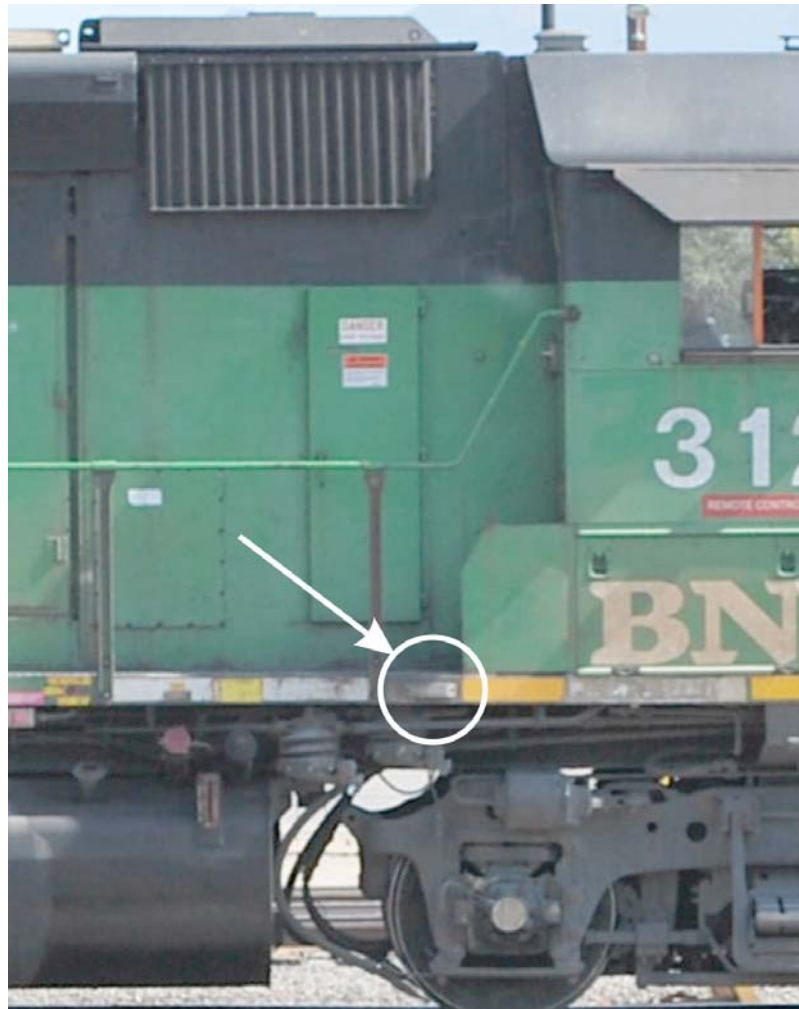
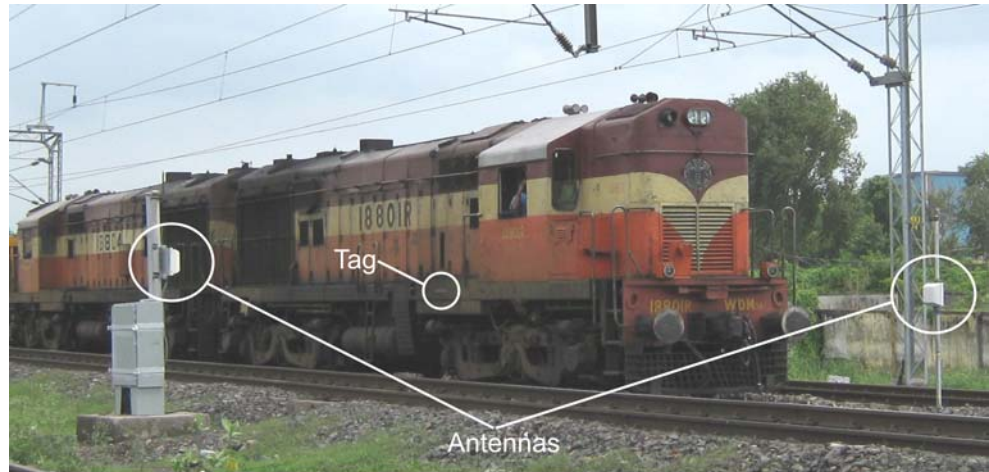

**Figure 2-3 Horizontally Polarized Tag**

---

### ***Unobstructed Line of Sight***

For optimum readability, install the MPRR and antenna(s) and the railcar's tag so that when the railcar approaches the antenna(s), the tag is directly facing the antenna and the line of sight is clear between the antenna and the tag. If there is a physical obstruction between the tag and the antenna(s), the MPRR cannot reliably read the tags. [Figure 2-4](#) illustrates possible installation locations of an antenna in relation to a tag's mounting location on a railcar.



SD-0159

**Figure 2-4 Antenna Location Relative to Tag Position**

## **Antenna Selection**

---

This section contains guidelines that assist in antenna selection for an MPRR installation that uses an external antenna. The following antennas are compatible with the MPRR installation.

### **AA3110 Parapanel**

Appropriate for installations with the following requirements and conditions:

- 902 to 928 MHz operation
- Exposure to harsh environments
- Broad radiation pattern in one dimension, narrow in the other
- Low antenna profile
- Horizontal polarization

### **AA3140 PCB Log Periodic**

Appropriate for installations with the following requirements and conditions:

- 845 to 950 MHz operation
- Exposure to harsh environments
- Maximum coverage at close range (<20 ft [6.1 m])
- Vertical or horizontal polarization

## ***Site Layout and Traffic Flow***

---

The following site layout and traffic flow considerations are critical when determining MPRR installation locations:

- The MPRR read zone
- Other MPRRs and antennas in the area
- Reflection, refraction, and diffraction of RF signals
- Existing signal interference at the site

---

### ***The MPRR Read Zone***

The MPRR must be able to read the tag data properly within a specified area, called the read zone, without reading other nearby tags or interfering with other MPRRs at the site. The following are some of the factors that affect the size and shape of the read zone:

- Mounting method used for the antenna
- Mounting location of the antenna
- Height from the ground and mounting angle of the antenna
- RF output attenuation
- Range discrimination setting
- Other sources of interference and reflection

The railside antenna must be positioned so that the RF signal travels to and return from the tags within the designated range and must be placed in an area where it is not likely to be bumped out of alignment. If the antenna becomes misaligned or some nearby structure is added or removed, system operation can be seriously affected.

For instructions on setting the read zone, see [“Fine-Tuning and Verifying the Read Zone” on page 8-18](#).

---

### ***Other MPRRs and Antennas in the Area — AAR-formatted Tag Operation***

For AAR-formatted (continuous wave) tag operation, sites with more than one MPRR in proximity be configured with a frequency separation of at least 2 MHz from adjacent readers. If more than one MPRR is in a multiple track application, the frequencies should be staggered. MPRR antennas can face each other across a rail track as long as they are multiplexed and controlled by the same MPRR. For installations where multiple antennas are controlled by a host processor with multiple MPRRs, or where multiple MPRRs are used in close proximity, ensure that there is adequate frequency



separation between the antennas. Contact TransCore Technical Support with any questions. [Table 2-1](#) shows examples of staggered reader frequencies in a site with up to seven readers.

**Table 2-1 Examples of Staggered Reader Frequencies for AAR-formatted Tag Operation**

Rail Number	Reader Frequency
1	911.50
2	918.50
3	913.00
4	915.00
5	921.50
6	917.00
7	910.00

---

## **Reflection, Refraction, and Diffraction of RF Signals**

RF signals can be reflected, refracted, or diffracted by metal objects, walls, and even wet pavement or ice. Any of these factors can alter or degrade system performance. When designing your site plan, you must consider permanent structures and transient factors in the vicinity that may affect RF signals being generated by the MPRR. Permanent structures include buildings, chain link fences, guard shacks, and gates. Transient factors include passing traffic and local weather conditions, such as rain or snow. Symptoms of reflection, refraction, and diffraction include reading tags that are out of the desired read zone or tags being read from another track.

The most common RF reflectors are metallic surfaces. RF signals may also be partially reflected by nonconducting materials such as dirt containing high concentrations of metallic rail dust, wood, ice, asphalt, and concrete. When nonconducting materials in the system environment become wet, they increase reflection of RF signals.

The antenna mounting location, aiming, and range control adjustment, and use of presence detectors can reduce interference from RF reflections. When these actions cannot adequately control reflections, other techniques such as shielding, absorbing, range sensitivity adjustment, or barriers can also be used. See [Chapter 9, “Troubleshooting and Maintenance”](#) for more information.

---

## **Existing Signal Interference at the Site**

Interference from RF and electrical sources can degrade system performance and also must also be considered in the site design. Fluorescent lights, neon signs, nearby radio stations, or power lines can interfere with the optimal operation of the system.

Interference may degrade both reader and tag performance. Existing sources of interference at the site should be shielded, removed, or positioned farther from the antenna. In some cases, changing the operating frequency of the MPRR may provide a simple solution. Readers in proximity should have at least a 2 MHz frequency separation. See [“Other MPRRs and Antennas in the Area — AAR-formatted Tag Operation”](#) on page 2-8. Strong RF sources of any frequency, in proximity to the tag, can preclude the tag receiving the reader interrogation. See Chapter 9, [“Troubleshooting and Maintenance”](#)

## ***Electrical and Communications Requirements***

---

All construction work at the site must be completed before installing the MPRR. Electrical and communications cables should be installed according to all applicable local and federal building code requirements. Specific instructions for positioning and installing the MPRR are discussed in Chapter 4, [“Installing the Multiprotocol Rail Reader”](#)

---

### ***Power and Communications Cables***

Cable length for power and communications depends on the physical characteristics of the MPRR installation site. [Table 2-2](#) lists accessory kits available for cabling options based on your site’s requirements.

**Table 2-2 Connector Cabling Accessory Kits**

<b>Part Number</b>	<b>Description</b>
58-7001-001	MPRR-to-TRU™ six-foot cable assembly
58-7001-002	MPRR-to-TRU 20-foot cable assembly
58-7001-003	MPRR cable assembly six-foot, no TRU
58-7001-004	MPRR cable assembly 20-foot, no TRU

### ***Electrical Power***

When connecting the MPRR to a TRU in a trackside hut, the MPRR draws its power directly from the TRU. A dedicated power supply is only required when a MPRR is not connected to a TRU.

The dedicated power must be 16-20V AC or 16-28V DC. A step-down transformer is available (North America only) to convert a 110V AC duplex wall outlet with ground to 18V AC, as is a step-up transformer to convert a low-voltage 12V AC outlet to 18V AC. Consult your local and national electrical codes for installation and safety requirements.

**Note:** *MPRRs installed outside North America require a locally supplied transformer.*

TransCore offers a Class C transformer accessory kit (part number 76-1620-005) for sites where 110V AC is available. It is the installer’s responsibility to supply conver-

sion equipment and wiring for other voltages. [Table 2-3](#) contains power supply current requirements.

**Table 2-3 Power Supply Current Requirements**

Supply	(RF On) Worst Case Maximum Current at 68°F (20°C)	(RF Off) Standby Operating Current at 68°F (20°C)
16 to 20V AC	1.7 A at 18V AC	1 A at 18V AC
16 to 28V DC	1.7 A at 18V DC	1 A at 18V DC

Power circuits are protected internally against power surges.

---

## Host Communications

Your site design must include communications between the MPRR and the TRU or other host device. The MPRR communicates with the TRU or other host device through an asynchronous RS-232 interface. [Figure 2-5](#) shows the MPRR communications port and [Figure 2-6](#) shows the connector pin designations.

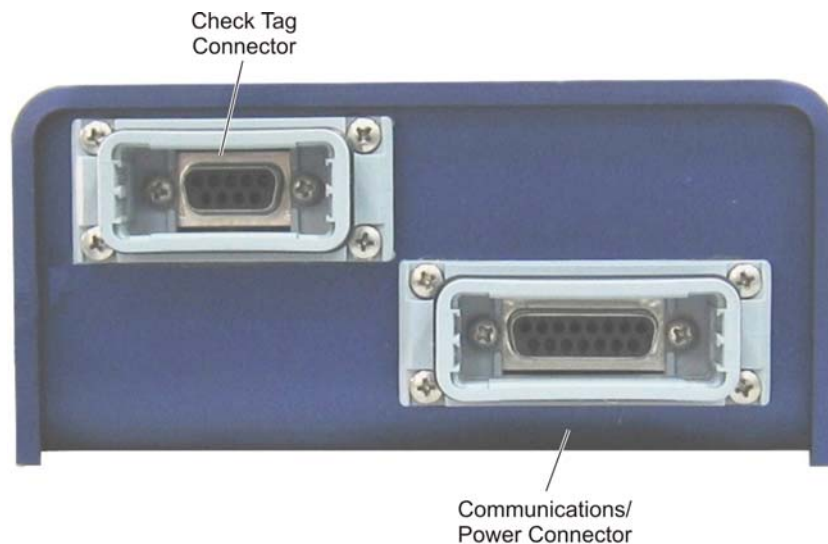

HW-0416

**Figure 2-5 Location of Communications/Power Port on MPRR**

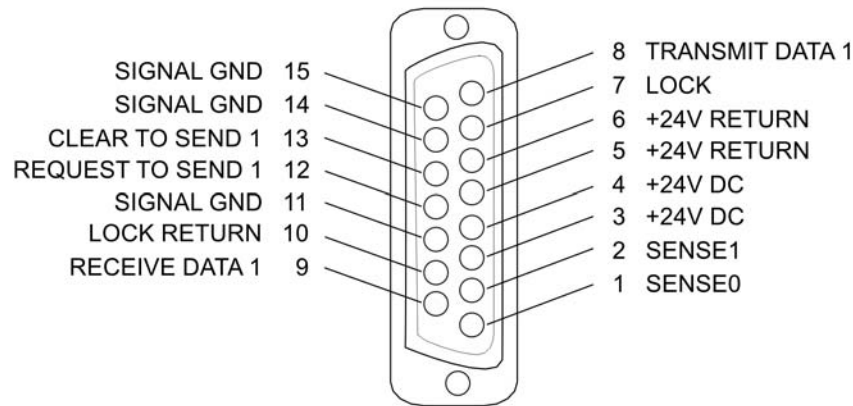

HW-0415

**Figure 2-6 Pin Assignments for Communications Connectors**

The standard RS-232 connection maximum distance depends on the baud rate, cable type, and the RS-232 device at the other end.

---

### **Input/Output Circuits**

The MPRR’s two RF sense input circuits are designed to connect to dry contact closures. The MPRR’s tag lock output circuit is a single-pole, double-throw relay providing a dry contact closure. These contacts are rated at 42.2V AC peak (30V<sub>rms</sub>) or 60V DC, at 1 A maximum with noninductive load.

Output circuit is not intended for the direct control of electromechanical devices such as motorized barrier arms. For such applications, the MPRR output circuit should be used to drive a secondary, appropriately rated high-power relay.

---

### **Antenna Interface**

The site design must include interface cable(s) between the MPRR and the compatible antenna(s) chosen for the site. The antenna interface is RF coaxial cable with male Type N sockets on each end.

Table 2-4 is a summary of coaxial cable performance. Figures indicate maximum lengths of cable in feet.

**Table 2-4 Reader to Antenna Cable Performance**

Cable Type <sup>a</sup>	Overall Diameter (in.)	Maximum Cable Length (ft.) 915 MHz	
		Low Loss <sup>b</sup>	Medium Loss <sup>c</sup>
RG-223	0.216	6	18
RG-214	0.425	12	37
FHJ1-50	0.250	16	48
FSJ1-50	0.250	15	45
LDF2-50	0.375	28	85
FSJ4-50B	0.500	27	83
LDF4-50A	0.500	42	128
LDF5-50A	0.875	76	229
LDF6-50	1.125	103	310
LDF7-50A	1.625	122	366

a. Suffixes 50, 50A, and 50B indicate 50-ohm cables available from the Andrew Corporation.

b. These cable lengths ensure optimal system performance (1 dB loss).

c. These cable lengths ensure adequate, but not optimal, system performance (3 dB loss).



---

## Choosing, Installing, and Removing Tags





---

# Choosing, Installing, and Removing Tags

*This chapter describes the various tag types compatible with the Multiprotocol Rail Reader (MPRR) and the procedures for installing and removing compatible external tags.*

## Compatible Tag Types

---

The MPRR provides the capability to read Association of American Railroads (AAR) formatted tags and TransCore Super eGo (SeGo) protocol tags. See [Appendix E](#) for information about the numerous tag models.

---

### Reader and Tag Model Interoperability

Table 3-1 lists the tags that are read by the MPRR. See [www.transcore.com/pdf/Tag-Reader-Matrix.pdf](http://www.transcore.com/pdf/Tag-Reader-Matrix.pdf) for most current information concerning readers and supported tag protocols.

**Table 3-1 Tags Read by the MPRR**

Beam Tags	Battery Tags	External Power Tags
AT5110, AT5112, AT5118, AT5125, AT5133, AT5412	AT5114, AT5510, AT5549, AT5707	AT5117, AT5119, AT5704

---

## Recommended Mounting Locations

Each piece of rail equipment has a specific area or *window* for optimum tag placement. Tag positioning in the tag placement window is based on the center of the tag in reference to window physical specifications.

---

### Required Materials

- Torque wrench (in/lb. range)
- Bolts and nuts (#10-24 NC threaded studs and nuts)
- Aluminum pop rivets
- Pop rivet gun

---

## ***Mounting Surface***

The mounting surface must be metal, vertical, and smooth within the area of the tag. If the mounting area does not meet this requirement, you must use a metal mounting bracket.

If the mounting surface is irregular or non-metal (e.g., fiberglass), the tag must be attached to a metal bracket to provide an electrical reflector for the tag. Use a 1/8-inch (0.32-cm) or thicker smooth metal bracket that is the same size or larger than the tag. The mounting bracket and tag must be in contact with each other to avoid interference with transmission of radio waves.

---

## ***Tag Positioning***

Each piece of equipment has a specific area or *tag placement window* for optimum tag placement. Tag positioning in the tag placement window is based on the center of the tag in reference to window physical parameters.

The tag placement window is on opposite ends and opposite sides of the equipment. The front and rear ends of the equipment are referred to as the “A” end and “B” end. The “B” end represents the hand brake end and the “A” end represents the opposite end looking forward. To determine left and right sides, stand at the “B” end and look toward the front end of the equipment.

Refer to the appropriate section for tag placement window location on rail cars and locomotive devices. Where possible, tags should be mounted in locations that minimize the likelihood of damage from equipment such as forklifts, cranes, and other hazards.

Mount the tag on a plane perpendicular to the rail (back of the tag against the equipment) with the long edge of the tag horizontal to the rail.

There is a clear zone surrounding the tag and toward the wayside that allows for unobstructed data transmission. This zone must not be obstructed by any metallic objects or protrusions.

As Figure 3-1 illustrates, there should be no obstructions in the area extending 45° from the center line of the tag to one inch outside either narrow side of the tag. The side view depicts the tag as viewed from the top of the equipment.

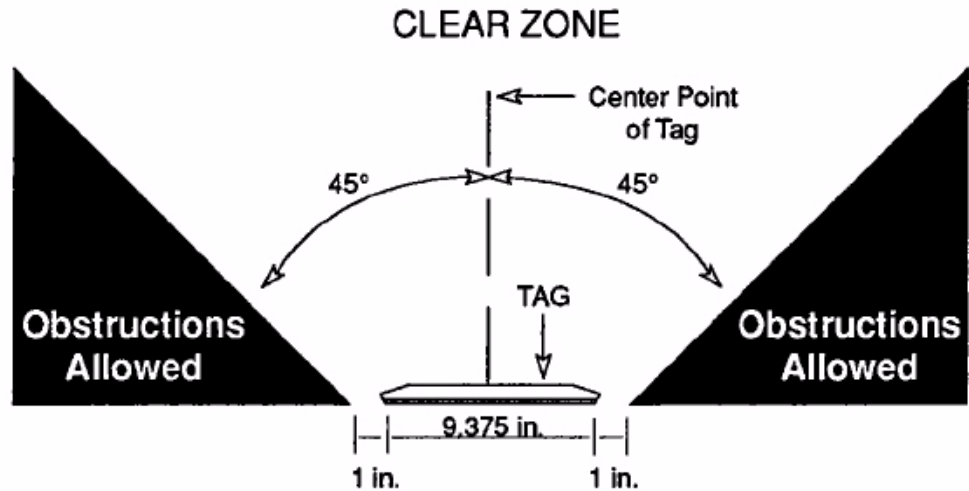

Figure 3-1 Clear Zone - Side View

Figure 3-2 illustrates that there should be no obstructions in the area extending 60° from the center line of the tag to 1 inch outside either long side of the tag. The end view depicts the tag as viewed from the end of the equipment.

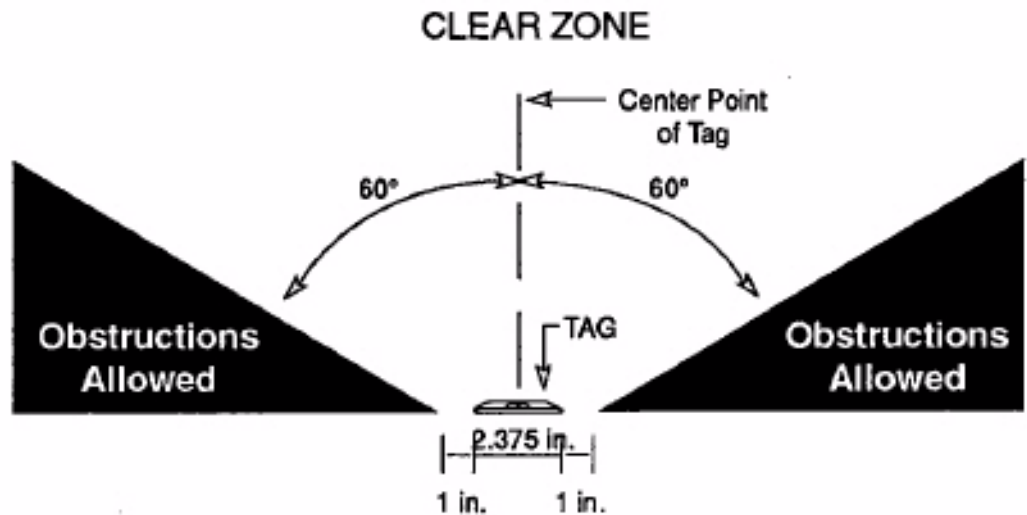
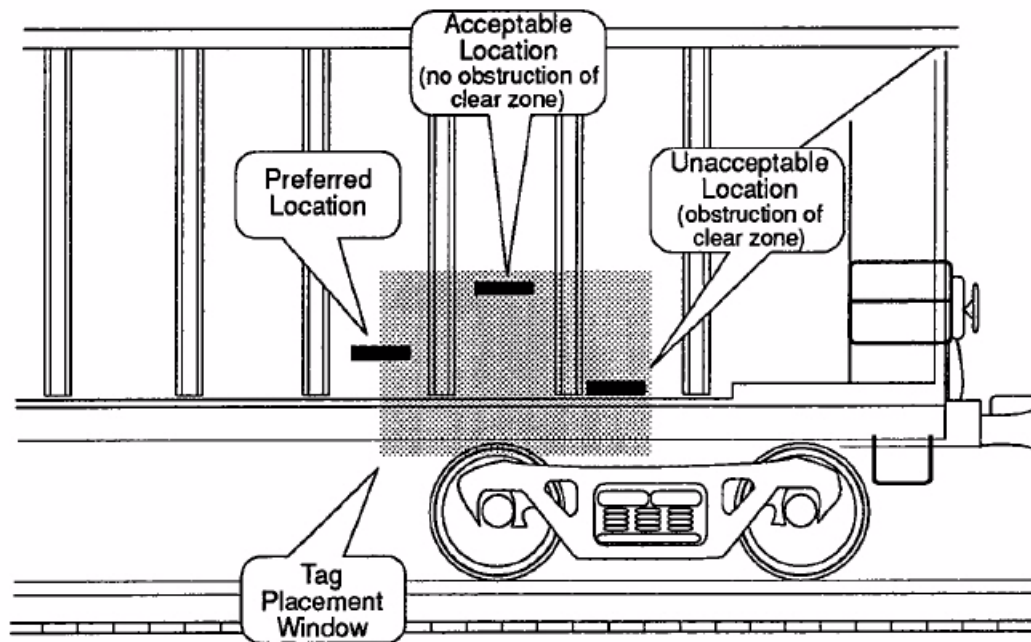

Figure 3-2 Clear Zone - End View

Figure 3-3 shows examples of acceptable and unacceptable mounting locations based on the clear zone. Any obstructions in the clear zone may introduce reading problems

with the tag. Refer to the mounting specifications chapters for each type of equipment for tag placement window locations.



**Figure 3-3 Mounting Location Examples**

---

## **Surface Installation Techniques**

Backing plates are preferred for attaching tags to equipment, but tags may be mounted directly to the car at the owner's discretion. Aluminum material is permitted as a substitute for the mounting plate material specified, when required for compatibility with the car surface.

When painting the backing plates, protect the studs from paint.

Two approved methods for mounting tags and backing plates on locomotives and railcars are rivet and bolt mounting.

*Note: Weld the backing plate to the freight car side sheet, but be certain the backing plate is kept flat. If the car side sheet is deformed, spacing of welds may vary to accommodate waviness of the freight car side.*

*Note: Allow the backing plate to cool after welding before mounting the tag.*

### **Rivet/Bolt Mounting Guidelines**

Select a means for mounting the tag that secures the tag but does not compromise the tag case.

Aluminum pop rivets are permissible, but TransCore advises against using high-pressure rivets for mounting the tag.

If using bolts and nuts to mount the tag, avoid using excessive torque, which may crack or break the tag case. Tighten the nut until snug, then tighten an additional 1/2 turn only.

## ***Locomotive Mounting Guidelines***

---

Install two tags on each locomotive on opposite ends and opposite sides of the equipment. Install one on the right front (engineer's side) and another on the left rear (fireman's side).

### ***Tag Placement Window Location***

Horizontally, the tag placement window extends from the center line of the truck to two feet from the center line of the inside axle (measure toward the center of the vehicle). Vertically, the tag placement window begins two feet above the top of the rail and extends to a maximum of five feet above the top of the rail.

Figure 3-4 illustrates the tag placement window on the right front portion (engineer's side) of the locomotive.

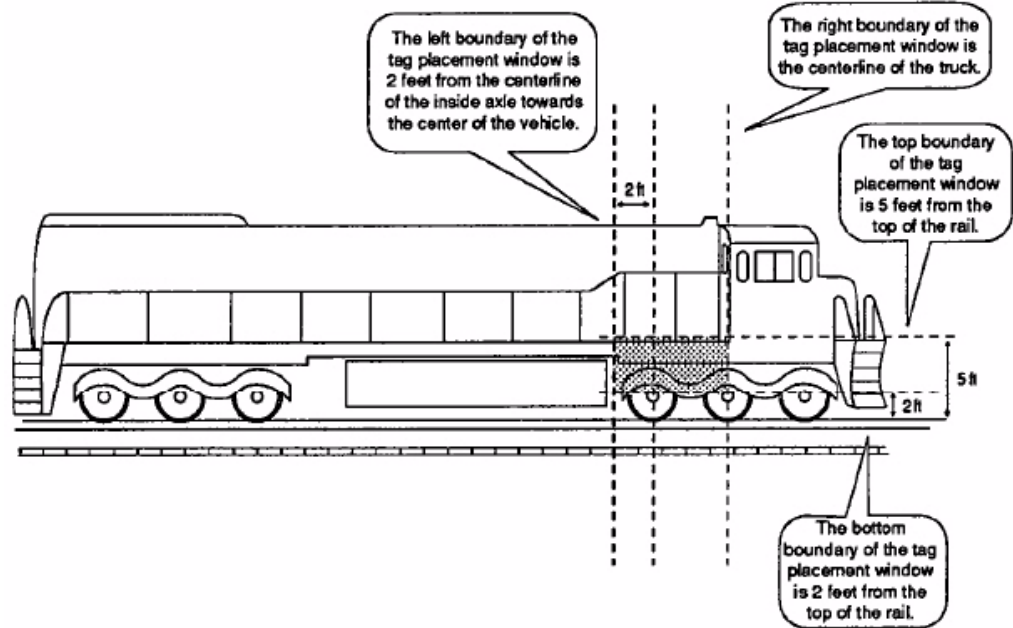

**Figure 3-4 Tag Placement Window for Locomotives -- Right Front**

Figure 3-5 shows the right front location of a tag on a locomotive.



Figure 3-5 Right Front Placement of Tag on Locomotive

Figure 3-6 illustrates the tag placement window on the left rear portion (brakeman's side) of the locomotive.

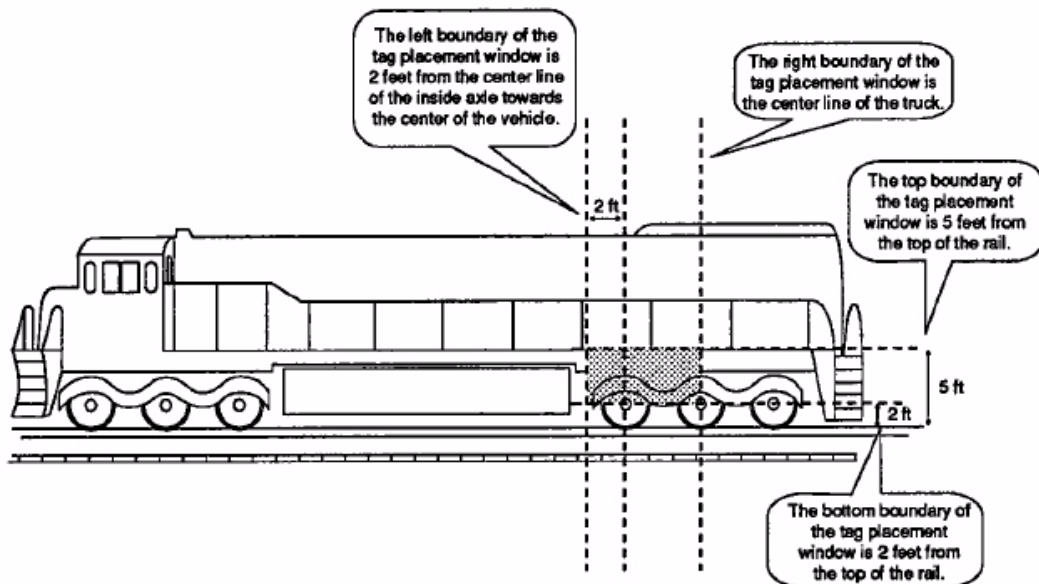

Figure 3-6 Tag Placement Window Location for Locomotives — Left Rear

---

## Tag Placement

Optimal tag placement centers the tag on the left boundary line of the tag placement window (Figure 3-7). Alternately, the center of the tag may be mounted anywhere within the tag placement window, provided there are no obstructions to the tag's clear zone.

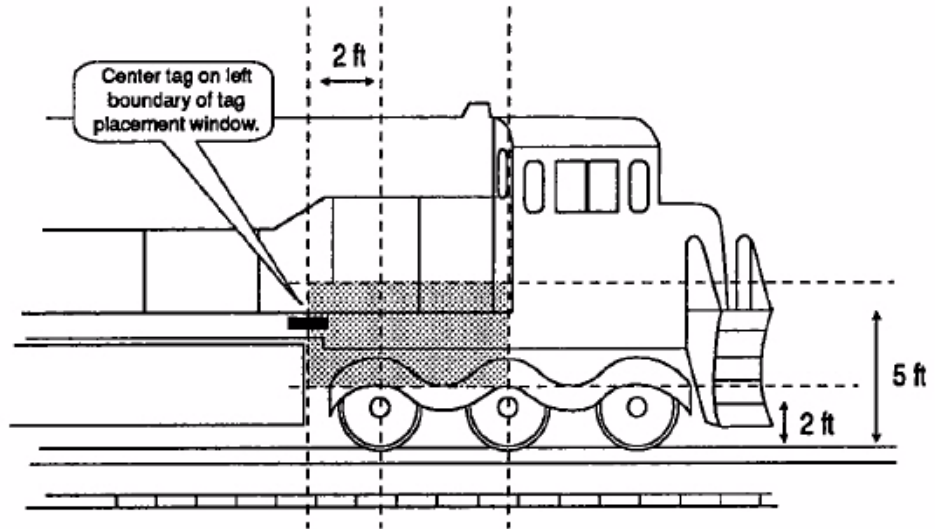

Figure 3-7 Optimal Tag Placement for Locomotives

---

## Rail Car Mounting Guidelines

Install two tags on each rail car on opposite ends and opposite sides of the equipment. Install one on the right front ("A" end) and another on the left rear ("B" end).

---

### Tag Placement Window Location

Horizontally, the tag placement window extends from the center line of the truck to two feet from the center line of the inside axle (measure toward the center of the vehicle). Vertically, the tag placement window begins at two feet above the top of the rail end and extends to a maximum of five feet above the top of the rail. The tag should not cover car stenciling.

Figure 3-8 illustrates the tag placement window on the right front portion (“A” end) of the rail car.

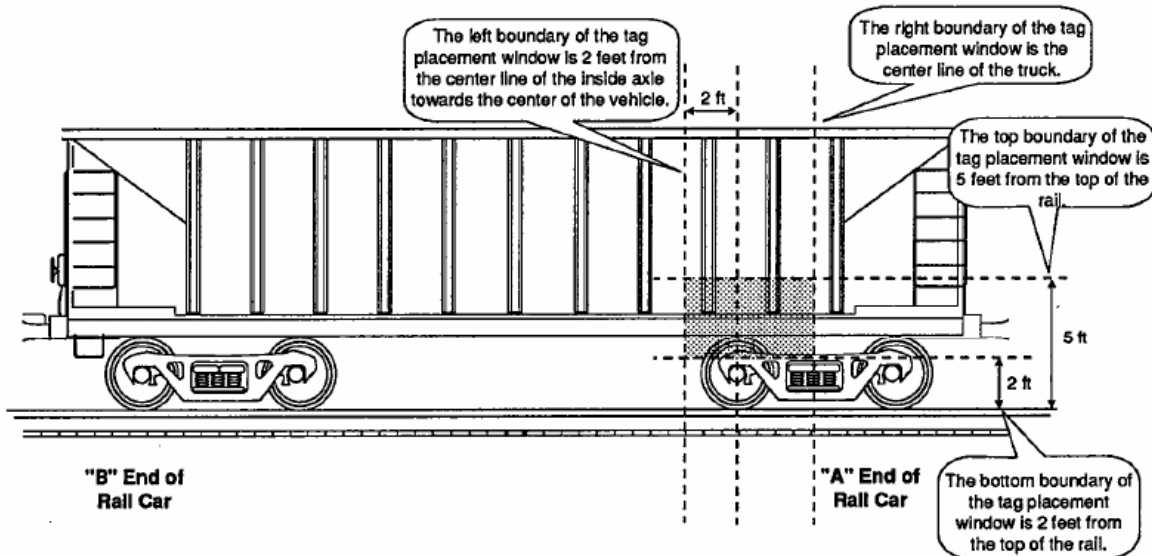

Figure 3-8 Tag Placement Window Location for Rail Cars -- “A” Right Side

Figure 3-9 illustrates the tag placement window on the left rear portion (“B” end) of the rail car.

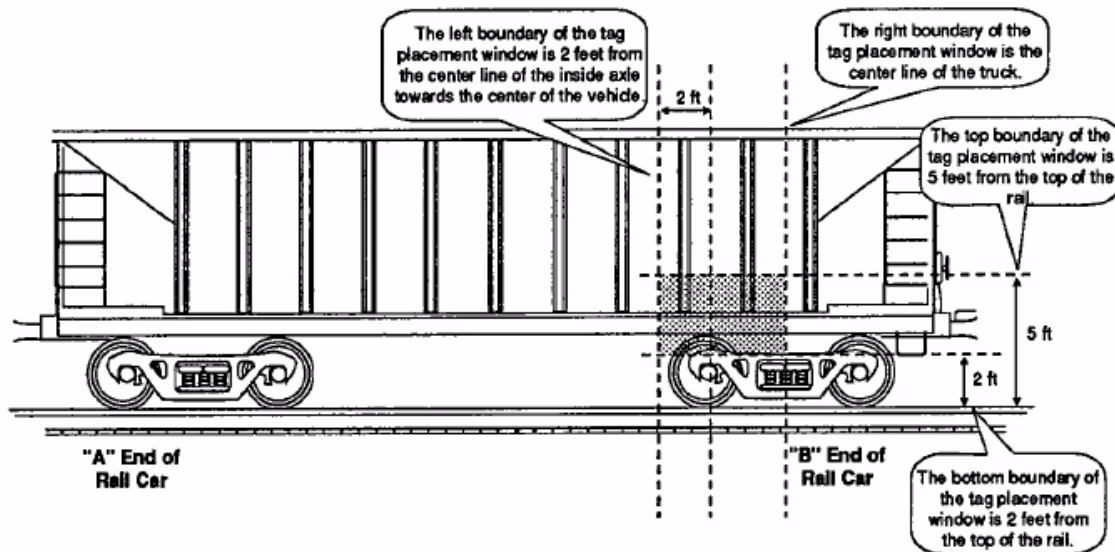

Figure 3-9 Tag Placement Window Location for Rail Cars -- “B” Left Side

## Tag Placement

Optimal tag placement centers the tag on the left boundary line of the tag placement window (Figure 3-10). Alternately, the tag may be mounted so that the center of the



tag falls anywhere within the tag placement window, provided there are no obstructions of the tag's clear zone.

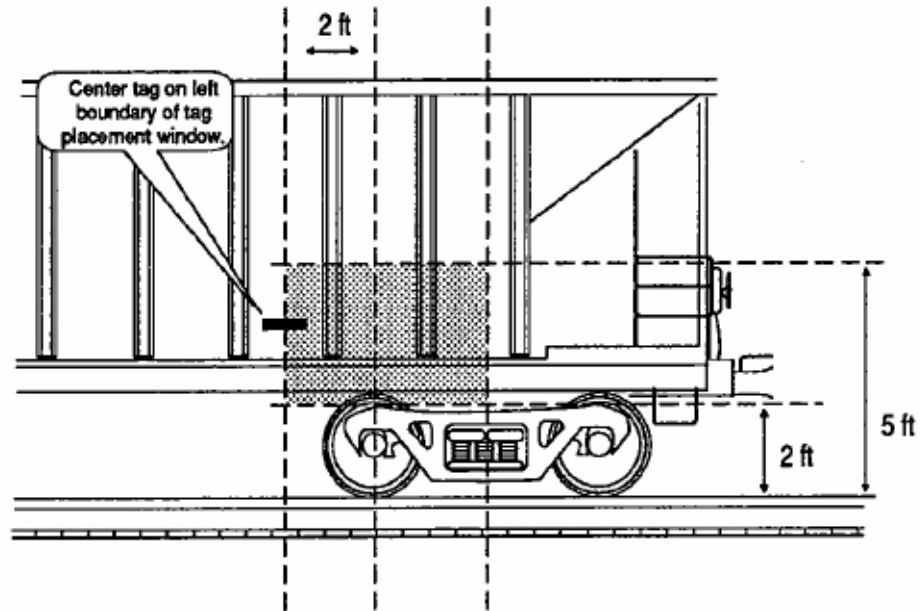

Figure 3-10 Optimal Tag Placement for Rail Cars

## Tank Car Mounting Guidelines

---

Tank car mounting is essentially the same as that for rail cars, except that the tag placement window area has been expanded 18 inches to the right of the center of the truck.

### Tag Placement Window Location

Horizontally, the tag placement window extends from 18 inches to the right of the center line of the truck to two feet from the center line of the inside axle (measured toward the center of the vehicle). Vertically, the tag placement window begins at two feet above the top of the rail and extends to a maximum of five feet above the top of the rail. The tag should not cover car stenciling.

Figure 3-11 illustrates the tag placement window on the left rear portion (“B” end) of the tank car.

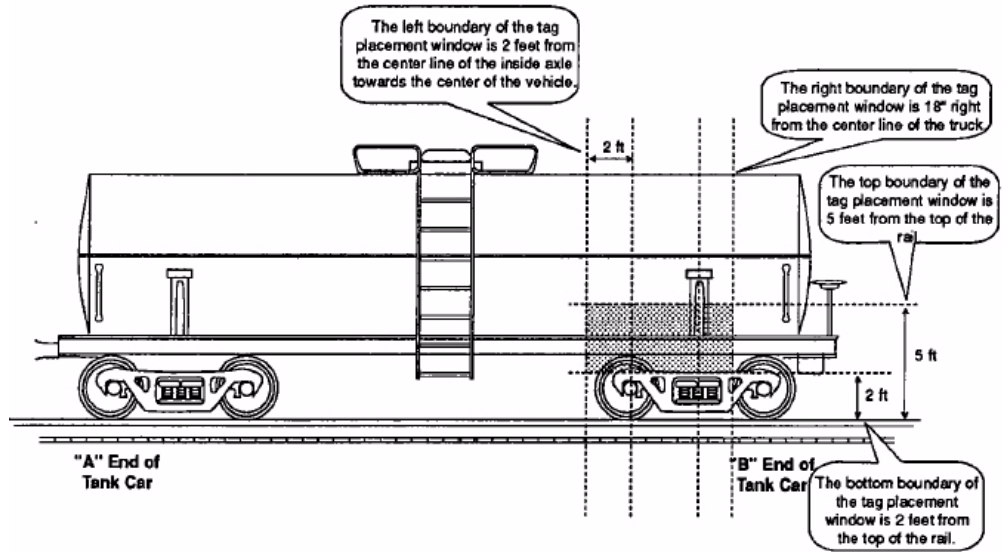

Figure 3-11 Tag Placement Window Location for Tank Cars -- "B" Left Side

### Tag Placement

Optimal tag placement positions the tag on the center line of the truck on the body bolster (Figure 3-12). Alternately, the tag may be mounted so that the center of the tag falls anywhere within the tag placement window, provided there are no obstructions of the tag's clear zone.

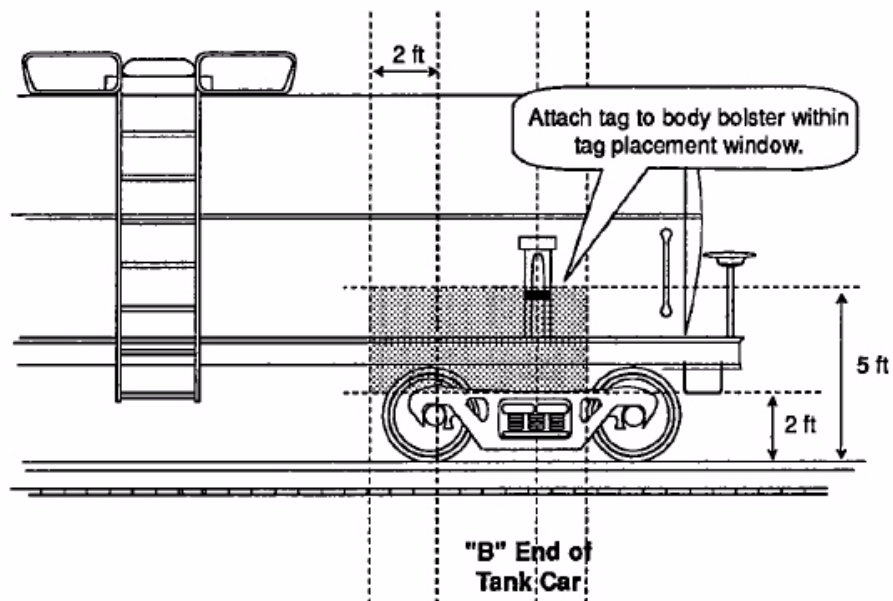

Figure 3-12 Optimal Tag Placement for Tank Cars

---

## Installing the Multiprotocol Rail Reader



# Installing the Multiprotocol Rail Reader

*This chapter lists the materials needed and presents the procedures to pre-test and install the Multiprotocol Rail Reader (MPRR).*

## **Installation Process**

---

After you have developed the site plan and identified the location to install the MPRR and antennas<sup>1</sup>, if required, you are ready to install the equipment. Installation involves the following tasks:

- Power and tag read capability testing prior to final installation of the MPRR
- Mounting the MPRR in a raiiside hut
- Mounting the raiiside antenna(s)
- Connecting the antenna(s)
- Connecting the MPRR to Earth Ground and power source
- Marking the read zone
- Connecting the MPRR host and sense input/sense output and communications

---

## **Materials Supplied by TransCore**

You need the following materials to pre-test and install the MPRR. TransCore supplies some of the materials; other materials must be obtained from other sources.

### **Contents of Shipping Carton**

Ensure that you have received all parts before beginning your pre-installation MPRR tests. Your MPRR is packaged with the following materials:

- One MPRR
- One *Multiprotocol Rail Reader Quick Start Guide*
- Any accessories ordered as options as shown in [Table 4-1](#)

Required accessories are a power/communications cable harness and a 110V AC-to-18V AC wall transformer, a 12 to 18V AC step-up transformer, or a 16 to 28V DC power source. You also require at least one MPRR-compatible antenna and an antenna RF cable. These may be ordered as accessories from TransCore or obtained from other sources.

---

1. The MPRR is designed with RF cable connectors for use with N-type RF cables.

For MPRR installation with TransCore’s Train Recording Unit (TRU™), see [Chapter 10, “Interface to Train Recording Unit.”](#)

### **Installation Accessory Options**

[Table 4-1](#) lists optional TransCore MPRR installation accessory items.

**Table 4-1 Installation Accessories**

<b>Part No.</b>	<b>Description</b>
58-7001-001	MPRR-to-Train Recording Unit (TRU) 6-foot (1.8-m) cable assembly
58-7001-002	MPRR-to-TRU 20-foot (6.1-m) cable assembly
58-7001-003	MPRR 6-foot (1.8-m) cable assembly, no TRU
58-7001-004	MPRR 20-foot (6.1-m) cable assembly, no TRU, 20
20-7001-001	MPRR check tag accessory kit

---

### **Additional Materials Needed for Testing**

You need these additional materials to perform the pre-tests on the MPRR:

- Test tags, supplied by the TransCore dealer or distributor.

*Note:* The test tag must be mounted flush against a metal backplane.

- Suitable 16 to 20V AC or 16 to 28V DC power wiring for the MPRR
- Audible circuit tester and 9V DC battery for circuit tester power
- Wire stripper
- At least one MPRR-compatible antenna
- Suitable RF interface coaxial cable

---

## **Pre-installation Testing of the MPRR**

Before installing the MPRR permanently at the site, you should use an audible circuit tester to confirm that the MPRR has power and can read a tag that is in the tag read zone.

---

### **Testing the MPRR Using an Audible Circuit Tester**

An audible circuit tester is also called a buzz box. These boxes are available at some electronic parts supply stores, or you can make a buzz box, as shown in [Figure 4-1](#). The buzz box is powered by a 9V DC battery and is equipped with two alligator-clip leads. When you touch the leads together, the box makes an audible sound.

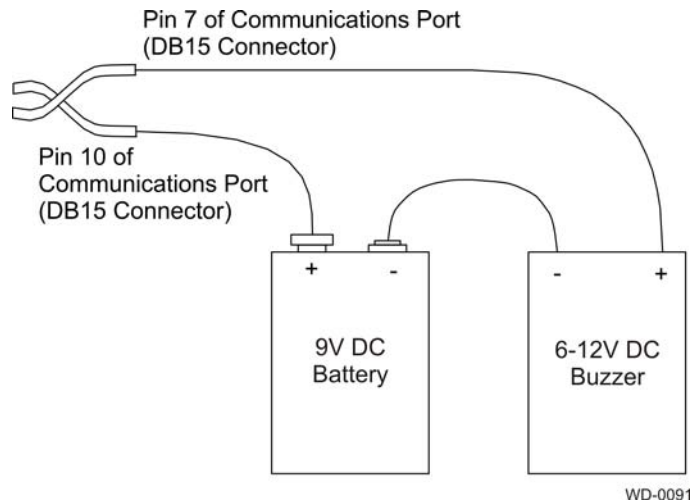

**Figure 4-1 Wiring for Audible Circuit Tester**

To test the MPRR, connect the antenna and power supply as described in the appropriate section below.

---

## **Discharging Voltage from the Antenna**

Use these instructions to discharge high voltage from the antenna before proceeding with further pre-installation testing of the reader connected to an antenna.

### **Required Equipment**

This procedure requires the following equipment.

- MPRR
- External antenna
- Grounding RF cable (long enough to reach Earth Ground source)
- N-type load (e.g., 50  $\Omega$ ) or RF attenuator (e.g., 20 dB)



### **Caution**

*During shipping and installation, an antenna can build up a very high voltage charge. The voltage needs to be discharged before connecting the antenna to the reader.*

1. Terminate the reader end of the grounding RF cable with any N-type load or RF attenuator (Figure 4-2).

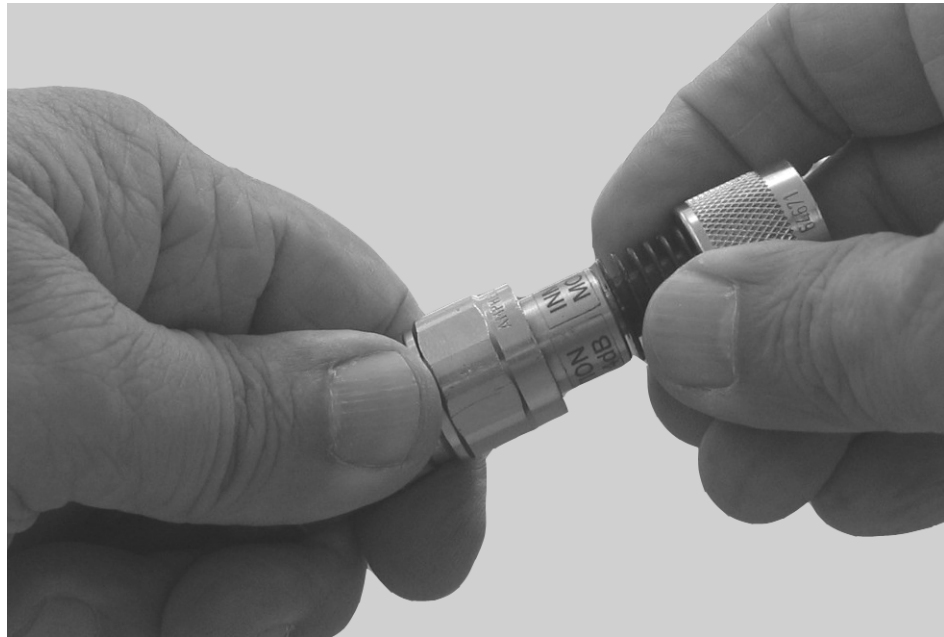

**Figure 4-2 Connect RF N-type Load or Attenuator to Reader Cable End**

2. Connect the grounding RF cable to the antenna (see Item 1 in [Figure 4-3](#)).

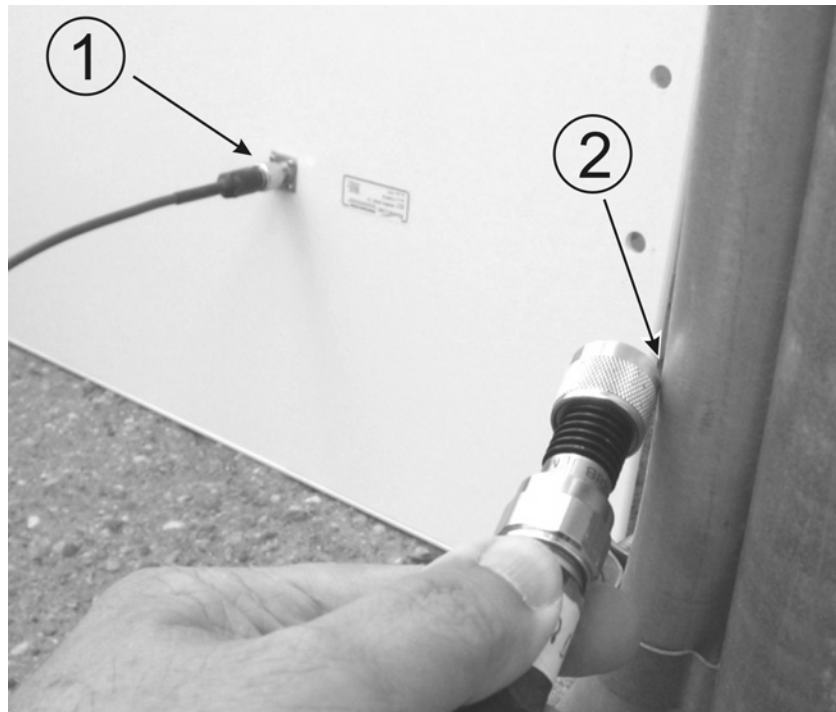

**Figure 4-3 Short Load to Earth Ground**

3. Short the outer metal case of the load or attenuator to Earth Ground for approximately 10 seconds (see Item 2 in [Figure 4-3](#)). In this example, the



operator is using the mounting pole that has been properly connected to Earth Ground.

4. Disconnect the grounding RF cable from the antenna and connect the permanent RF cable to reader.

Once the antenna is discharged and properly connected to the reader, the reader circuitry provides a DC path to keep any further charge from building up in the antenna.



### Caution

*TransCore does not recommend using a screwdriver or other tool to short the RF cable center conductor to the outer ground of the cable. This grounding method can damage the center pin or the threads of the connector.*

*TransCore strongly advises that you use adequate Earth Ground for this voltage discharge procedure in accordance with the National Electric Code for the locale where you are installing the MPRR.*

---

## Connecting the Antenna

This section explains the connection between the MPRR and antenna(s) (Figure 4-4).

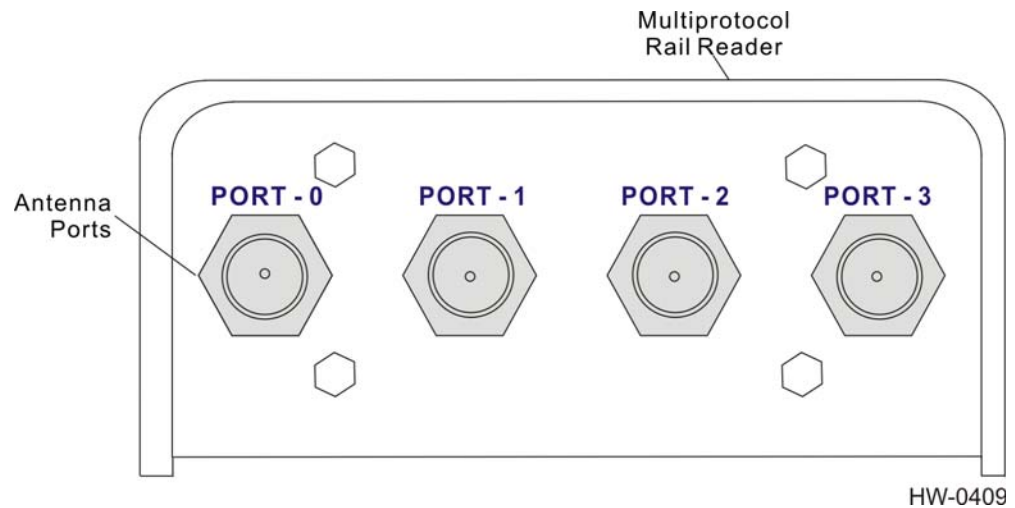

**Figure 4-4 MPRR Showing Antenna Ports**

### To connect the reader and antenna

1. Ensure the reader is turned off and unplugged.
2. Connect one end of the RF interface cable to the antenna.
3. Connect the other end of the RF interface cable to the appropriate antenna port on the end of the MPRR. See Figure 4-4.
4. For consistent performance, terminate unused antenna ports using a 50-Ohm, N-type terminator.

---

## Connecting the MPRR to a Power Supply



### Caution

- To avoid damage to the MPRR, first connect the reader to Earth Ground using a ground cable and stake before powering up the reader or connecting to an antenna. TransCore recommends that you follow the National Electric Code or equivalent code for surge protection for the locale where you are installing the MPRR.
- Connect any antenna(s) or terminate the antenna ports before applying power to the reader.

### To connect the MPRR to a power supply

1. Connect the MPRR to Earth Ground. [Figure 4-5](#) shows the location of the MPRR ground stud.

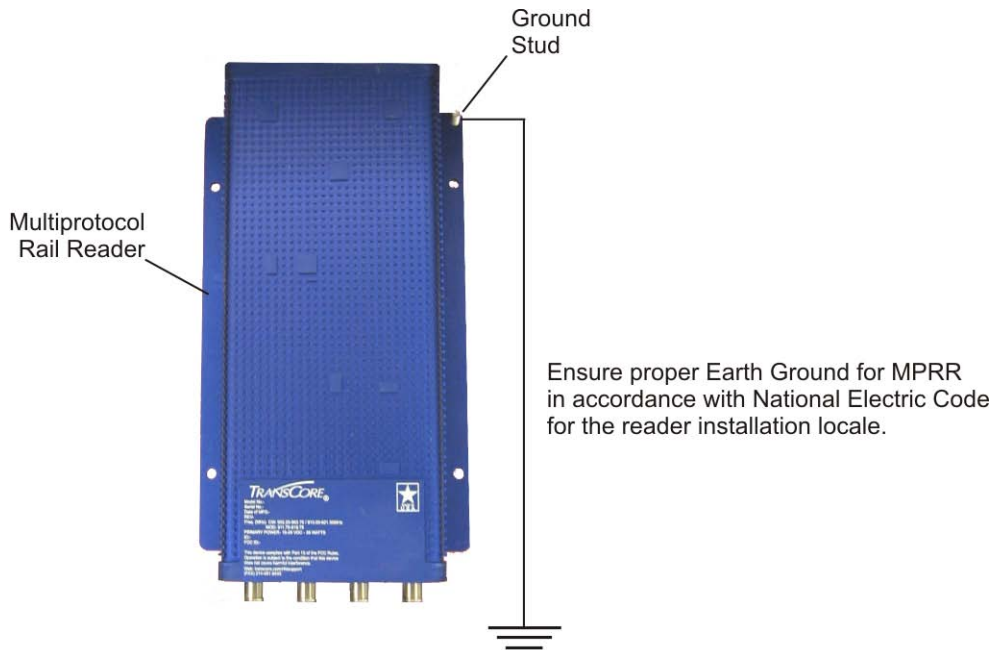

WD-0093

**Figure 4-5 Location of MPRR Ground Stud**

2. Connect the MPRR to a power supply using the interface cable.

The pin numbers for the reader DB15 connector ([Figure 4-6](#)) is shown in [Figure 4-7](#) and the pin assignments and corresponding wire numbers and colors are listed in [Table 4-2](#).

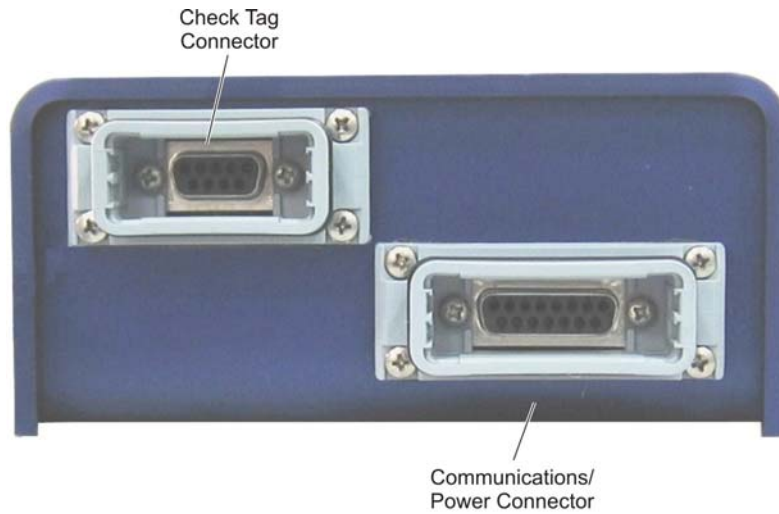

HW-0416

Figure 4-6 Location of Communications/Power Port on MPRR

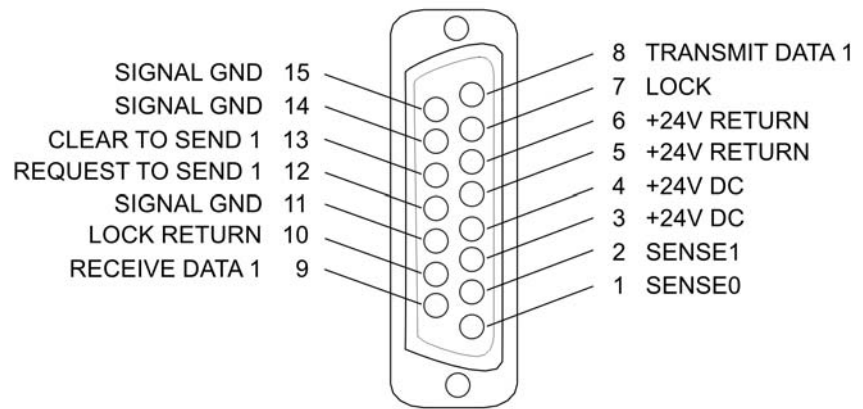

HW-0415

Figure 4-7 Pin Assignments for Signal to Host Connectors

Table 4-2 MPRR-to-Host Communications Cable Pin Designations

Pig Tail Pin Number	Color	Signal Description
1	Black	SENSE0
2	White	SENSE1
3	Red	+24V DC
4	Green	+24V DC
5	Orange	+24V RETURN

**Table 4-2 MPRR-to-Host Communications Cable Pin Designations**

Pig Tail Pin Number	Color	Signal Description
6	Blue	+24V RETURN
7	White/Black	LOCK
8	Red/Black	TRANSMIT DATA 1
9	Green/Black	RECEIVE DATA 1
10	Orange/Black	LOCK RETURN
11	Blue/Black	SIGNAL GROUND
12	Black/White	REQUEST TO SEND 1
13	Red/White	CLEAR TO SEND 1
14	Green/White	SIGNAL GROUND
15	Blue/White	SIGNAL GROUND

If the MPRR is connected directly to a TRU, all power supply connections are made through the MPRR-to-TRU cable assembly. Refer to [Chapter 10, “Interface to Train Recording Unit”](#) for wiring assignments.

## **Mounting the MPRR**

---

This section lists procedures and materials required for mounting the MPRR on a wall or other flat surface based on the site’s requirements.

In permanent installations the MPRR should be positioned as close as possible to the antenna. Long cable runs increase system sensitivity to noise. See [Table 2-4 on page 2-13](#) for maximum RF cable lengths.

TransCore advises that for optimum heat dissipation, you mount the MPRR vertically with the RF antenna ports at the bottom (refer to [Figure 4-5](#)). [Figure 4-8](#) shows the outer dimensions and mounting hole locations for preparing to install the MPRR.

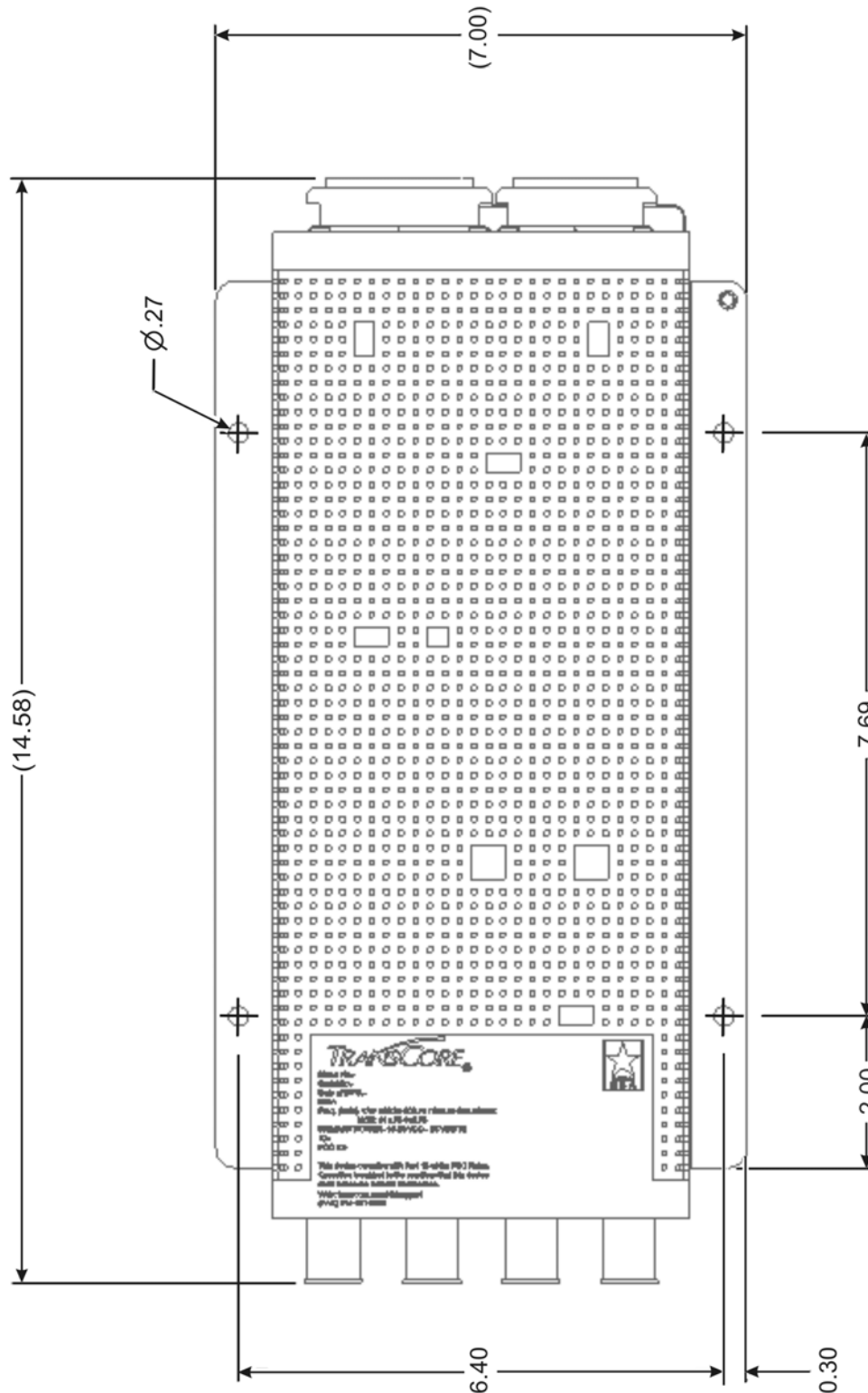

Figure 4-8 MPRR Outer Dimensions and Mounting Hole Locations

---

## Mounting to an Enclosure Wall or Flat Surface

### Required Materials

You need the following materials to install the MPRR on an enclosure wall or flat surface. Ensure the use of high-quality, corrosion-resistant anchor hardware.

- Anchor hardware suitable for the surface on which you mount the MPRR

The MPRR weighs 5.1 lbs (2.3 kg) so choose mounting hardware that is adequate to secure the unit to a wall.

After mounting the MPRR, you must connect it to a dedicated 16 to 20V AC or 16 to 28V DC power supply.



### Caution

*To avoid damage to the MPRR, connect the antenna(s) before applying power to the reader.*

---

## Mounting the Antenna Rail-Side

Position the antenna as close as possible to the MPRR. Long cable runs increase system sensitivity to noise. See [Table 2-4 on page 2-13](#) for maximum RF cable lengths. This section provides guidelines for mounting antennas.

After mounting the antenna, you must connect it to the MPRR. Follow the procedures described previously in the section [“Connecting the Antenna” on page 4-7](#).

*Note: Adjust the antenna(s) to provide the most direct line of sight to the tags.*

---

## Connecting the Power Supply

After mounting the MPRR, connect the reader to a dedicated 16 to 20V AC or 16 to 28V DC power supply. If the MPRR is connected directly to a TRU, all power supply connections are made through the MPRR-to-TRU cable assembly.



### Caution

*To avoid damage to the MPRR, connect the MPRR to ground before powering up the reader or connecting the antenna(s).*

*Connect the antenna(s) before applying power to the reader.*

---

## Connecting Communications

The MPRR communicates through RS-232 protocol.

---

## **Required Materials**

You need the following materials to connect the communications cable (P/N 58-7001-003 or 58-7001-004) to the host device:

- Host device
- Any terminal emulation program such as Procomm Plus or Hyper Terminal operating on a PC
- If the MPRR is connected directly to a TRU, all communications connections are made through the MPRR-to-TRU cable assembly (P/N 58-7001-001 or 58-7001-002).

---

## **Connecting the MPRR to the Host**

MPRR communications and customer interface signals are supplied from the MPRR to the host through a multiwire cable. The connector for this cable is located on the end of the MPRR (Figure 4-6).

Plug one end of the MPRR communications/power interface connector into the DB15 connector at the MPRR and the other end into the customer-supplied host device connector. Refer to Figure 4-7 and Table 4-2 for the pin assignments and numbers, and the wire colors.

---

## **Connecting Sense Input and Sense Output Circuits**

The MPRR has two sense input circuits and a tag lock output circuit available. SENSE0 is used to enable RF on antenna ports 0 and 1 if enabled, and SENSE1 is used to enable RF on antenna ports 2 and 3. The sense input circuits are used to notify the MPRR of train presence and are designed to be connected to a free-of-voltage dry contact. The tag lock output circuit is a single-pole, double-throw relay that provides a normally closed and normally open dry contact. The relay contact is rated at 42.2V AC peak (30 Vrms) or 60V DC at 1 A maximum. If controlling an external gate or device requiring high current, an isolation transformer is required.

---

### **Sense Input Circuits**

The MPRR supports two sense inputs – SENSE0 and SENSE1 – which require two sense input lines (SENSE<sub>x</sub> and GND) for each loop sense or a total of four sense input connections. SENSE0 is used to control RF power for the track that has antennas connected to RF Ports 0 and 1. As shown in Figure 4-7, the sense inputs are wired through the reader DB15 connector. The MPRR expects the SENSE0 circuit to close when a railcar is present (on the track with antennas connected to MPRR ports 0 and 1). SENSE1 must be closed when a railcar is present on the track connected to MPRR antenna ports 2 and 3. The reader RF switches on to the appropriate RF ports immediately upon detecting SENSE<sub>x</sub>.

---

## Sense Output Circuit

The sense output is dedicated for testing and reader setup. It is defined as the TAG\_LOCK signal, which indicates a valid tag is in the read field.

This sense output is a dry contact that provides a normally open and normally closed sense output. The relay contacts are rated at 42.2V AC peak (30 V<sub>rms</sub>) or 60V DC at 1 A maximum. If controlling an external gate or device requiring high current, an isolation transformer is required.

---

## Marking the Read Zone



### Caution

*Be sure to follow all applicable rail safety regulations when marking the read zone.*

The area where the MPRR reads tags at the current RF range is called the read zone. The antenna pattern, or read zone, of the MPRR would look roughly like a pear-shaped balloon if you were able to see it. When installing the MPRR, you should first mark the unit's read zone using the RF range set at the factory-default maximum. You can later adjust the read zone using the techniques discussed in [“Fine-Tuning and Verifying the Read Zone”](#) on page 8-18.

If two MPRRs are installed near each other, TransCore recommends that you fine-tune each reader for the ideal read zone before connecting it permanently to sense input/sense output and communications cables. A minimum of 2 MHz frequency separation and 40 feet (12.2 m) of antenna separation between the two adjacent readers is required for correct operation.

---

## Required Materials

You need test tags, which can be supplied by your TransCore dealer or distributor to mark the read zone. The test tag must be mounted flush against a metal backplane.

### To mark the read zone

1. Confirm that you have correctly connected the power supply/communications cable as described in this chapter.
2. Start the terminal emulation application Microsoft HyperTerminal by selecting **Programs>Accessories>Communications>HyperTerminal** and press **ENTER**.
3. In the HyperTerminal dialog boxes choose the com port to which the communications interface is attached and set the properties as:
  - Bits per second: 9600 baud
  - Data bits: 8
  - Parity: none
  - Stop bits: 1
  - Flow control: none



4. Cycle the power on the MPRR and ensure that the sign-on message displays.
5. To test the antenna connected to RF PORT-0, input the commands listed in [Table 4-3](#).

*Note: For testing purposes, the MPRR should not be in MPRR mode and should not be multiplexing between multiple antennas. MPRR mode is used for rail track smart multiplexing.*

*Note: Settings for RF, ATA range, SeGo range, and output power are the same for all antennas.*

**Table 4-3 Commands for Testing RF Port-0**

Entry	Reader Response	Notes
#01 <CR>	#Done <CR/LF>	Switches MPRR to command mode
#647XXX	#Done <CR/LF>	Sets operating frequency
#836	#Done <CR/LF>	Disables MPRR mode
#850	#Done <CR/LF>	Disables antenna multiplexing
#644XX	#Done <CR/LF>	Set desired RF power
#643XX	#Done <CR/LF>	Set desired ATA range control
#645XX	#Done <CR/LF>	Set desired SeGo range control
#6401	#Done <CR/LF>	Turns on RF
#00 <CR>	#Done <CR/LF>	Returns MPRR to data mode

You can now connect the outer marks to draw the outer boundary of the read zone.

[Figure 4-9](#) is a view of a sample read zone. The outer X marks show the outside edges of the read zone.

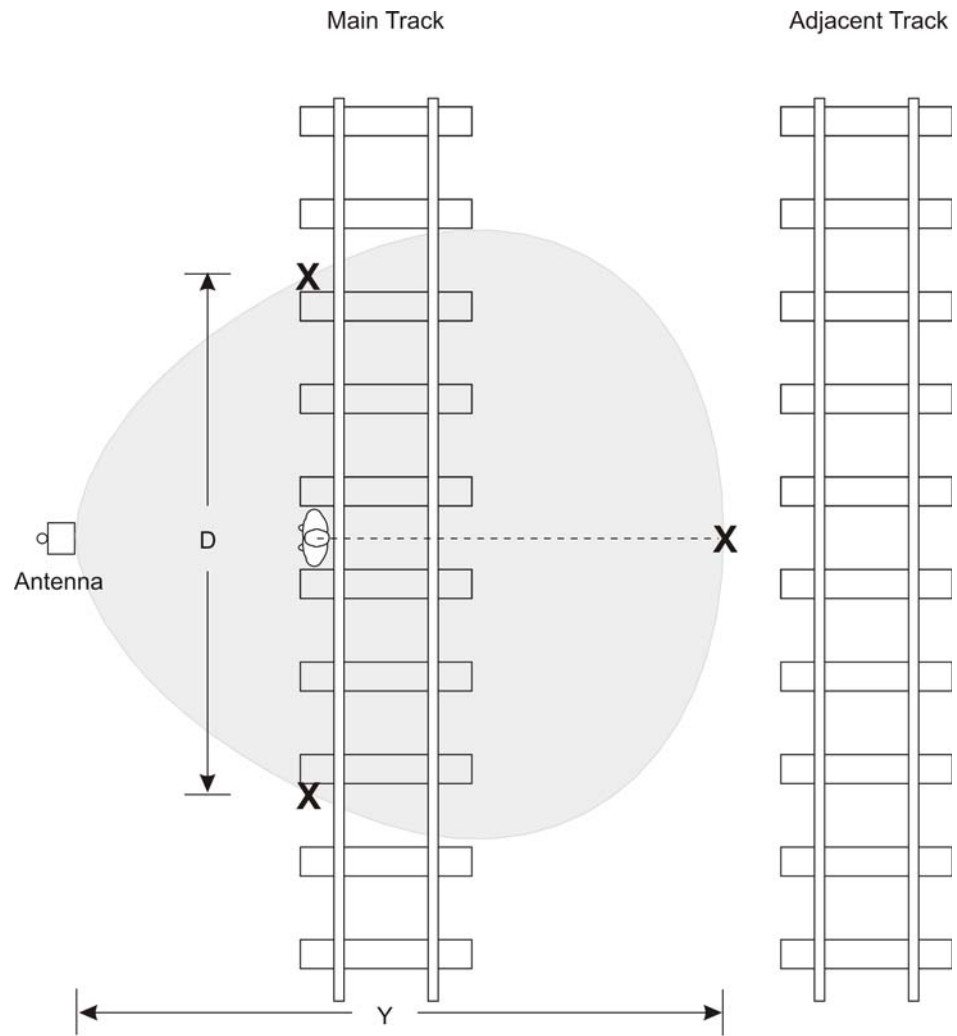

SD-0158

**Figure 4-9 Sample Read Zone Marking Pattern**

6. Place the MPRR in single-antenna operation using the antenna of interest. Standing at the edge of the rail sleepers closest to the antenna walk the metal-backed test tag along the track to determine the farthest read point in both directions (see item D in Figure 4-9). Record the distance.
7. In a multiple track installation, walk the tag toward the adjacent track in a straight line from the antenna face (see Figure 4-9) to determine whether the MPRR reads tags from the adjacent track. Record that distance (item Y). If the MPRR reads tags on the adjacent track, reduce the range control value, or increase RF attenuation until the MPRR cannot read tags on the adjacent track.

To continue testing other antennas, ensure that the reader configurations used for RF PORT-0 antenna (Table 4-3) are maintained. The following tables list the required commands for testing PORT-1, PORT-2, and PORT-3.

**Table 4-4 Commands for Testing RF PORT-1**

<b>Entry</b>	<b>Reader Response</b>	<b>Notes</b>
#01 <CR>	#Done <CR/LF>	Switches MPRR to command mode
#891	#Done <CR/LF>	Test mode, RF PORT-1 only
#6401	#Done <CR/LF>	Turns on RF
#00 <CR>	#Done <CR/LF>	Returns MPRR to data mode

**Table 4-5 Commands for Testing RF PORT-2**

<b>Entry</b>	<b>Reader Response</b>	<b>Notes</b>
#01 <CR>	#Done <CR/LF>	Switches MPRR to command mode
#892	#Done <CR/LF>	Test mode, RF PORT-2 only
#6401	#Done <CR/LF>	Turns on RF
#00 <CR>	#Done <CR/LF>	Returns MPRR to data mode

**Table 4-6 Commands for Testing RF PORT-3**

<b>Entry</b>	<b>Reader Response</b>	<b>Notes</b>
#01 <CR>	#Done <CR/LF>	Switches MPRR to command mode
#893	#Done <CR/LF>	Test mode, RF PORT-3 only
#6401	#Done <CR/LF>	Turns on RF
#00 <CR>	#Done <CR/LF>	Returns MPRR to data mode



---

General Software Information



## General Software Information

***This chapter provides software-related information for the Multiprotocol Rail Reader (MPRR) System.***

This chapter presents various software-related topics arranged in alphabetical order by subject. In addition to this chapter, see Chapter 6, “[Communications Protocols](#),” and Chapter 7, “[Commands](#),” for more information.

### Command Entry Conventions

All MPRR commands are preceded by the start-of-message character (#). The end-of-message sequence expected from the host is a carriage return (CR). The MPRR terminates messages with a return and a line-feed (CR/LF). For example, the command #01 Switch To Command Mode is typed as follows:

```
#01<ENTER>
```

where <ENTER> is the Enter or Return key.

Some command characters may be represented by the letter N. This letter indicates you are to supply a value. Maximum valid entries are the numbers 0 through 9 and the uppercase letters A through F. These letters allow for as many as 16 available user responses and are based on the hexadecimal numbering system.

Commands have at least two characters following the # character. [Table 5-1](#) shows the basic structure of a four-character command.

**Table 5-1 Four-Character Command Structure**

#1005 <b>Set Baud Rate To 9600 Baud</b>	
#	All commands are preceded by the # character.
1	Indicates the command group. This command is in Group 1-Communications Port Control.
0	Indicates the command subgroup. In this example, all commands with a second digit of 0 apply to the main port.
0	The command digit. In this example, the 0 indicates that this command affects the baud rate.
5	Indicates the setting. Normally this is a variable and is usually a hexadecimal value from 0 through F. In this example, 5 sets the baud rate to 9600, the factory setting. In some commands, this digit may be a four-place hexadecimal string or a character string.

## Command Response Conventions

---

Like the MPRR commands, responses are preceded by the # character. Many MPRR commands respond with #Done or #Error indicating the command was or was not recognized and completed. Other commands respond with a four-character identifier followed by one or more values.

Table 5-2 shows an example of a command/reply sequence. This example assumes that an MPRR with serial number SN97001P running version X.XX software is connected to a PC running a terminal emulation software package such as Windows Hyper Terminal or Procomm Plus. The command sequence verifies that communications are working correctly.

**Table 5-2 Sample Command Sequence**

Entry	MPRR Response	Notes
#01 <CR>	#Done <CR/LF>	Switches MPRR to command mode
#505 <CR>	#Model E4 Series Ver X.XX SN08001P <CR/LF>	Reports the software version and serial number
#00 <CR>	#Done <CR/LF>	Returns MPRR to data mode

In command discussions, MPRR response characters may be shown in brackets <>. The use of brackets indicates that the response is a value in the range of characters. The brackets are not part of the response. For example, the response to command #520 Display Power Fail Bit is either a 0 or a 1. In the command discussion, the response is shown as:

#PWRB <0-1>

with actual MPRR response being one of the following:

#PWRB 0

#PWRB 1

In this example, PWRB is the four-character identifier for *power fail bit*, and the 0 or 1 is the value. All spaces shown in the response are actual spaces sent from the MPRR. In this example, one space is between the letter B and the number.

## Operating Parameters

---

The MPRRs maintain their operating parameters in nonvolatile memory (NVRAM) so that the parameters are preserved after a power-down sequence.



## Power Fail

---

The system maintains a power fail flag. The host transmits command #520 Display Power Fail Bit to determine if a power down has occurred. This flag is cleared by both command #63 Reset Reader and command #65 Reset Power Fail Bit.

## Program Download

---

Program download stores the MPRR application software into the reader's flash memory. Program download is used to install program upgrades, add features, and to recover from corrupted program data.

*Note: Program download is a custom TransCore utility hosted process.*

---

### Download Considerations

You should consider the following factors when performing program download:

- The MPRR does not process tags while in download mode.
- The MPRR does not accept any program data unless a successful erase of flash memory has been performed before transmitting the data. Erasing the flash memory typically takes two seconds.
- Cycling reader power after exiting from download mode re-executes startup. If the new software has been loaded without errors, the MPRR comes up in data mode. If a flash checksum error is detected, the MPRR reenters download mode and transmits a sign-on message with a boot version of 0.00x and without a serial number.

*Note: The MPRR uses default boot communications parameters when operating in download mode – 38400 baud, 8 data bits, 1 stop bit, no parity, basic protocol – and does not echo commands.*

---

### Download Procedures

If TransCore releases a new version of the MPRR software or if the MPRR does not appear to be working properly, you may need to download the software to the MPRR. Contact technical support or your TransCore MPRR sales representative.

## Startup

---

Upon startup, MPRR transmits a sign-on message or a boot ROM failure message.

---

## **Sign-On Message**

If startup is successful, the sign-on message appears as follows:

```
Model E4 Series [software version] SNSSSSSS  
[Copyright notice]
```

where SSSSSS is the serial number assigned to the MPRR unit being used.

Serial number 000000 is the default setting and is not a valid number. If this number appears in the sign-on message, the serial number has never been stored into reader memory. The serial number must be assigned by factory-authorized personnel using command #695S...S Set Serial Number. Because only six digits are allowed in the software, when setting the serial number skip the fourth (middle) digit of the seven-digit number shown on the reader label.

If the flash memory checksum does not indicate verification, the sign-on message appears as follows at a baud rate fixed at 38,400 bps:

```
Model [E4] Ver 0.00x  
[Copyright notice]
```

---

## **Boot Failure Message**

Upon powering up, the software performs a checksum verification on itself. The function returns a specific value for the particular version of software. If the value returned is not correct, the boot code assumes that the application code has been corrupted and a failure condition exists. If the failure message does not transmit, a communications error has occurred or the boot has failed to the extent that it cannot transmit the failure message.

If the failure message version number equals 0.00 and no serial number exists, the flash memory checksum has failed, and the MPRR is operating out of boot ROM. In this case, the MPRR automatically enters download mode and waits for a new program to be loaded into the flash memory. Contact TransCore Technical Support at 214-461-6449 for assistance.

---

## **Tag/Message Buffer**

MPRRs maintain a tag buffer in battery backed RAM to save tag IDs acquired when data inquiry protocol is used. This buffer holds up to 500 time-stamped messages. When the buffer fills, subsequent tag IDs will be lost.

---

# Communications Protocols



# Communications Protocols

*This chapter describes the communications protocols for the Multiprotocol Rail Reader (MPRR).*

## **Introduction**

---

The MPRR supports the following communications protocols:

- Basic
- Error correcting
- Data inquiry

The following protocol information provides reference information relevant to developing host software.

Communications are performed using the 7-bit ASCII code with optional parity, thus providing easy setup, testing, and diagnostics with standard ASCII terminals and serial printers.

Each message is framed within the start-of-message (som) and end-of-message (eom) characters so that the host device can detect the beginning and end of each message. This convention is most important under marginal communications conditions during which the host may receive extraneous noise-induced characters between reader transmissions. In such instances, the host is capable of ignoring any messages that do not conform to the som...eom frame sequence.

Both data mode and command mode require a two-way message interchange when using error correcting protocol (ECP). This interchange is completed by the message recipient returning a message acknowledgement to the message sender.

With ECP, all transmissions require a message. If a message is not received, the sender will time out with the same effect as if it had received a negative acknowledgment (from the host) or an `ERROR` message from the MPRR.

Software (XON/XOFF) flow control is optionally supported. Be careful in the use of XON/XOFF since noise-induced characters may be interpreted by the MPRR as the XOFF character, which would suspend reader output without information reaching the host device. For more information see [“Software Flow Control” on page 8-17](#).

***Note:** TransCore recommends that XON/XOFF flow control be disabled while using ECP.*

## ***Basic Protocol***

---

With basic protocol, messages sent to and from the MPRR and the host are transmitted without error checking. For each host transmission, the MPRR returns a `Done` or `Error` message to the host.

When the host device is physically close to the MPRR and no sources of interference exist, the basic protocol provides reliable communications.

The host must be ready to receive reader-transmitted messages because in basic protocol the MPRR does not wait for the host to acknowledge a message before transmitting the next message. If necessary, the host may halt reader transmissions by using software or hardware flow control. Refer to Chapter 8 for flow control information.

## ***Error Correcting Protocol***

---

When the quality of data communications is imperative or may be suspect, you can invoke ECP to ensure the integrity of data transmitted between the MPRR and the host.

*Note: TransCore recommends that basic protocol (not ECP) be used when commands are entered manually at the keyboard.*

Error correction is accomplished with the use of a cyclic redundancy check (CRC) value that is based on the message data. The originator (reader or host) calculates the CRC value of a message and includes it in the transmitted message.

The recipient (reader or host) also calculates a CRC value for the received message. If the transmitted message data is correct, the CRC value calculated by the recipient will agree with the CRC value calculated by the originator. If the CRC values do not agree, the recipient rejects the message.

Message sequence numbers are also included when using ECP. These sequence numbers are checked to determine if the message received has the correct sequence number; if not, the recipient rejects the message.

Because the seven-bit ASCII code is used and there are eight data bits per character, the eighth bit can optionally be used to support parity. Where parity is selected, the CRC value calculation includes the parity of each character in the calculation of the CRC value.

Parity is required to achieve the most reliable communications. If parity is enabled, both the MPRR and the host must issue a message if any received character has a parity error. However, the message must not be transmitted before receipt of the `eom` character. If the message is transmitted prematurely, the MPRR will issue an `Error` message, and the host device will issue a negative acknowledgment message.

## Data Inquiry Protocol

---

Data inquiry protocol is a basic protocol option that allows the host to control transmission of reader tag data. The selection of data inquiry protocol affects data mode operation. As MPRR acquires tags, it buffers them but does not transmit them. Instead, the host must poll MPRR for each tag by sending a CTRL-E character (hex 5 digit). MPRR transmits one message (tag ID or report data) for each CTRL-E it receives until the buffer is empty.

Each tag request message sent by the host consists only of the CTRL-E character; no som or eom characters are sent. MPRR data transmission (tag ID and report data) format is the same as for basic protocol.

Selection of data inquiry protocol does not affect command mode operation.

## Basic Protocol and ECP Format

---

*Note: In the following text, the symbols < and > are used to represent required variable message data, and the symbols [and] are used to represent optional data. These symbols are not part of the message syntax.*

### Reader Transmissions

The basic protocol format and the data inquiry protocol format are as follows:

```
<som><data><eom>
```

The ECP format is as follows:

```
<som><seq><data><crc><eom>
```

where

<som>            Start-of-message (ASCII # character)

<seq>            Sequence number (ASCII hex) that represents an even number in the range 0–9, A–F (0, 2, 4, 6, 8, A, C, E). The MPRR maintains the number. The host must acknowledge reader transmissions by sending an ACK message with the same sequence number received from the MPRR. The MPRR updates its sequence number upon receipt of a valid host ACK. If an ACK is not received, the MPRR retransmits the message. A reader transmission sequence is not considered complete until the MPRR receives an ACK and updates its sequence number.

<data>           ASCII string up to 72 characters long. This string may contain tag data; a presence without tag report; an input status change report; an Error06, Error07, Error08, or Error11 message; or a sign-on message. Auxiliary data may also be included.

**<crc>** Field containing four ASCII digits that represent the 16-bit CRC value calculated on the message. The CRC value is calculated on bytes between the **som** character and the first **<crc>** byte.

When the host receives a properly framed message, it can calculate a 16-bit CRC value. The calculation is applied to the character string that immediately follows the **<som>** and that ends with the character immediately preceding the first **<crc>** character.

Transmitted CRC value can then be compared with the binary equivalent of the received **<crc>** characters. If the transmitted and received CRC values do not match, the recipient assumes the message was received in error, and transmits a **NAK** message response.

**<eom>** End-of-message characters (ASCII CR and LF). The system includes both a carriage return (CR) and line feed (LF) to facilitate the use of terminals and printers.

If the host receives a **<som>** character in the middle of a data message, the message in progress is aborted. The assumption is that an **<eom>** was lost and the MPRR is in the process of retransmitting the previous message.

---

## **ECP Host ACK/NAK Response**

With ECP, the host device responds to all data message transmissions from the MPRR using the following acknowledgment or negative acknowledgment response format.

**<som><seq><ack/nak><crc><eom>**

where

**<som>** Start-of-message (ASCII # character)

**<seq>** Echo of the sequence number received from the MPRR. The sequence number should correspond to the data message that is being positively or negatively acknowledged by the host. If the MPRR receives an ACK message with the incorrect sequence number, the data message is retransmitted.

The host device resets the anticipated data message sequence number to that of the MPRR before communications can resume without error.

**<ack/nak>** ASCII @ character for ACK response; ASCII ? character for NAK response

**<crc>** CRC value for the message

**<eom>** End-of-message character (ASCII CR)



The MPRR sets a user-programmable timeout delay at the time each message is transmitted based on command #612NN Set Error Correcting Protocol Timeout, where NN = timeout delay. To disable the timeout delay for diagnostic purposes, issue the command #612FF Disable Error Correcting Protocol Timeout.

If the timeout delay expires before the MPRR receives an ACK or NAK message from the host, a logical NAK condition will be declared. If the MPRR receives a NAK or timeout, the reader retransmits the data message.

When the MPRR receives an ACK message, the system software treats the message as having been properly received by the host. The software increments the sequence number, and advances pointers to the next message in the MPRR's message queue to prepare for sending the next message.

## Switch to Command Mode Request

The host device may issue command #01 Switch to Command Mode while in data mode.

The basic protocol format is as follows:

<som><cmd><eom>

The ECP format is as follows:

<som><seq><cmd><crc><eom>

where

<som>	Start-of-message (ASCII # character)
<seq>	Sequence number generated by the host device separately from that appearing in data messages transmitted by the MPRR
<cmd>	Switch to command mode (ASCII characters 01)
<crc>	CRC value for the message
<eom>	End-of-message character (ASCII CR)

## Host Transmission

The host device initiates synchronous communications between the MPRR and the host. The host begins a sequence by issuing a command; the MPRR responds accordingly.

The data inquiry protocol format is as follows:

<CTRL-E>

The basic protocol format is as follows:

<som><cmd>[ <data> ]<eom>

The ECP format is as follows:

`<som><seq><cmd> [ <data> ] <crc><eom>`

where

`<CTRL-E>` ASCII Control E (hex 5 digit). When in data inquiry mode, each transmission of a CTRL-E by the host causes the MPRR to transmit one tag ID.

`<som>` Start-of-message (ASCII # character)

`<seq>` Sequence number (ASCII hex digit) that represents an odd number in the range 0–9, A–F (1, 3, 5, 7, 9, B, D, F). The host should use odd sequence numbers in its command since the MPRR uses even sequence numbers in its transmissions. This method eliminates the possibility of a synchronous host command and an asynchronous reader transmission having the same sequence number.

Upon receiving a host command in ECP, the MPRR replies using the command's sequence number in its response. Therefore, the host device updates its sequence number upon receipt of a valid reader response. If the sequence number is not updated before transmission of the next command, the MPRR will not service the new command; it will retransmit its previous message. A command/message sequence is not complete until the host updates its sequence number.

`<cmd>` Command code, a string that contains from two to four ASCII hex characters

[ `<data>` ] Optional data field, an ASCII string of as many as 20 characters in length. For example, the store hardware configuration string command is #696S . . . S or command #696 Store Hardware Configuration String followed by the data string S...S.

`<crc>` CRC value for the message

`<eom>` End-of-message character (ASCII CR)

---

## ***Reader Command Response***

The basic protocol format is

`<som><resp><eom>`

The ECP format is

`<som><seq><resp><crc><eom>`

where

<som>	Start-of-message (ASCII # character)
<seq>	Echo of sequence number received in host command message
<resp>	Response string. The MPRR returns Done, Error, or another ASCII string depending on the host transmission. This string can be up to 72 characters long.
<crc>	CRC value for the message
<eom>	End-of-message character (ASCII CR and LF)

## Sample Messages

This section contains examples of typical messages transmitted between the MPRR and the host device.

### Reader Transmissions

Basic protocol reader transmission

```
#KING 1302<eom>
```

Host response

No host response for non-ECP

ECP reader transmission

```
#4KING 1302 <crc><eom>
```

where

#	Start-of-message character
4	Message sequence number
KING 1302	Message data: Tag ID is shown. Other sample message data could be as follows: IOST C0 O2 IO D24 (display I/O status) Error06 (frequency not set)
<crc>	CRC value for the message
<eom>	End-of-message character

Host response

```
#4@<crc><eom>
```

where

#	Start-of-message character
---	----------------------------

## **Multiprotocol Rail Reader System Guide**

4	Message sequence number
@	ACK (acknowledgment character) (? returned for a negative acknowledgment)
<crc>	CRC value for the message
<eom>	End-of-message character

### **Host Command Transmissions**

Basic protocol host transmission

#647XXX<eom>

Reader response

#Done<eom> or #Error<eom>

#Error<eom> is returned if the host transmission is not a legal command with legal data.

ECP host transmission

#7647XXX<crc><eom>

where

#	Start-of-message character
7	Message sequence number
647XXX	Select RF Operating Frequency command where 647XXX is the command and XXX is a hexadecimal value from 000 to 118. In this example, XXX sets the RF frequency to 903 MHz.
<crc>	CRC value for the message
<eom>	End-of-message character
Done	Command has been invoked by the MPRR

Reader response

#7Done<crc><eom> or #7Error<eom>

For some commands, the MPRR responds with data that relates to the command, such as TOF 0, to indicate the mode enabled for a #570 Display Operating Mode Status command.

#7Error<eom> will be returned if host transmission is not a legal command with legal data.

---

## Timing and Synchronization

The ECP is largely independent of baud rate. The timeout delays previously described are a function of baud rate.

The MPRR supports an ECP timeout, which applies equally to both transmit and receive.

The receiver's minimum timeout delay equals the time to transmit/receive the longest anticipated message at the current baud rate setting. Additional margin should be included for idle periods between characters; for example, processing overhead, if any. The timeout delay period can be expressed as follows:

$$T_{\text{rec}} (\text{ms}) = L \times [T_{\text{char}} + T_{\text{idle}}]$$

where

$$T_{\text{char}} (\text{ms}) = 1000 \times [B_c / R_b]$$

$B_c$  Bits per character, typically 10

$R_b$  Baud rate, 1200–38.4 K

$L$  Length of message in characters

$T_{\text{idle}}$  Maximum idle period between characters (ms)

*Note: The MPRR supports baud rates between 1200 and 38.4 K.*

Likewise, the sender must set a timeout delay equal to the delay of nine characters at the current baud rate setting. For example, the time required to shift out the <eom> character plus the time to shift in the ACK or NAK message to be received plus a processing allowance for the receiver to process the message and check for error conditions.

Thus, the sending timeout delay can be expressed as follows:

$$T_{\text{send}} (\text{ms}) = 9 * T_{\text{char}} + T_{\text{errchk}}$$

where

$T_{\text{errchk}} (\text{ms})$  Processing period to perform error checking by receiver

The host device can remotely set the MPRR's communications parameters while in the command mode, but TransCore does not recommend this action if communications conditions are marginal.

After the MPRR receives new communications parameters, the MPRR issues the Done message and switches to the new configuration immediately. The host device switches its communications parameters immediately after the transaction is complete.

As noted, the message initiator, such as the MPRR in data mode and the host device in command mode, starts a timeout counter at the time a message is transmitted. If the timeout expires before receiving an acknowledgement message, a logical NAK condition is declared, and the initiator assumes the message was received in error. In this instance, the message is retransmitted until an acknowledgement message is received.

The message recipient, such as the host device in data mode and the MPRR in command mode, starts a timeout counter when a <som> character is received. If the timeout expires without the receipt of an <eom> , the message acquisition is aborted (reset), and the receiver waits for the next <som> character.

If the message recipient receives a second <som> character before an <eom> character, the message acquisition is aborted (reset), and retransmission of the previous message is assumed to be underway.

These strategies allow for recovery during periods when communications are marginal or lost completely.

*Note: It is important that the host device limit the period during which the MPRR remains in command mode to avoid losing tag IDs. RF is off in command mode and no tags can be read.*

---

## **Reader-Addressed Failure Conditions**

The MPRR addresses the following failure conditions.

### ***Illegal Sequence Number (not in the range 0–9, A–F)***

If the MPRR detects an illegal sequence number in a host command message, it discards the received message and sends no response. If it receives an illegal sequence number in an ACK message, it responds as if a NAK had been received and retransmits the data.

### ***Wrong Sequence Number***

If the MPRR receives the wrong sequence number in an ACK message, it responds as if a NAK had been received, and it retransmits the data.

### ***Incorrect CRC***

If the MPRR detects an incorrect CRC value in a host command message, it discards the received message. No response is sent. If it receives an incorrect CRC value in an ACK message, it responds as if a NAK had been received, and it retransmits the data.

### ***Illegal Command***

If the MPRR receives an illegal command, it returns its standard Error message.

### ***Transmission Timeout***

If the MPRR transmits an asynchronous message and the host does not send an ACK before the ECP timeout occurs, the MPRR retransmits the message.

### **Receive Timeout**

If the MPRR receives a <som> but does not receive a matching <eom> before the ECP timeout occurs, it discards the incomplete message and resets its receiver.

### **Asynchronous Message/Command Message Collision**

If the MPRR transmits asynchronous data at the same time that the host sends a command, the MPRR gives priority to receiving the command. It processes the command and sends a message before it retransmits the asynchronous data.

---

## **Host-Addressed Failure Conditions**

The host device addresses the following failure conditions.

### **Illegal or Wrong Sequence Number**

If the host detects an illegal or wrong sequence number in a reader response, it retransmits the command with the same sequence number. If the host detects an illegal sequence number in an asynchronous reader transmission, it sends a NAK message.

### **Incorrect CRC**

If the host detects an incorrect CRC value in a reader message, it retransmits the command with the same sequence number. If the host detects an incorrect CRC value in an asynchronous reader transmission, it transmits a NAK message.

### **Transmission Timeout**

If the MPRR does not respond to a host command within a specified interval, the host software retransmits the command with the same sequence number.

### **Receive Timeout**

If the host receives a <som> but does not receive a matching <eom> within a specified timeout interval, it discards the incomplete message and resets its receiver.

### **Asynchronous Message/Command Message Collision**

If the host receives an asynchronous reader transmission at the same time it transmits a command, it ignores the asynchronous message and waits for the MPRR's response. The MPRR retransmits asynchronous data after it transmits the command message.

---

## **ECP Reliability**

An undetected error is defined as a message having incorrect data or status but no parity or CRC errors. An error transaction is defined as a message having either a parity or CRC error. Laboratory testing indicates an undetected error rate of less than one undetected error per 1,000,000 error transactions with parity enabled.

To ensure this error rate is not exceeded, the host must enable parity and adhere closely to the timing specifications discussed previously in the [“Timing and Synchronization” on page 6-11](#) section.

## **CRC Calculation**

---

The CRC used by the ECP is based on a 16-bit algorithm. The algorithm, as implemented, operates on eight-bit characters, for example, a seven-bit ASCII character plus one optional parity bit. The 16-bit result is converted to four ASCII hex characters and is appended to messages transmitted by the MPRR.

The MPRR accepts four ASCII < ` > characters (60 hex) as a wild card CRC value in lieu of a valid four-character CRC value to facilitate testing and diagnostic checkout.

The MPRR implements the algorithm with a 512-byte lookup table to reduce the processing overhead requirements.

To simplify the implementation of the CRC algorithm by host software developers, several examples of the calculation are provided in C source code on the following pages. The calculation may be performed with or without a lookup table, depending on the trade-off between code memory and processing overhead.

Example 1 presents an example of a function (CALCCRC) that calculates the CRC value through a call to a separate function (UPDCRC).

```
unsigned short calccrc(char *message)
{
    unsigned short crc = 0;
    for ( ; *message != (char)0; message++)
        crc = updcrc(*message & 0xff, crc);
    return (crc)
}
```



Example 2 shows an example of UPDCRC that does not require a lookup table.

```
#define BITS_PER_CHAR    8
unsigned short updcrc (unsigned short ch, unsigned short
crc)
{
    register short counter = BITS_PER_CHAR;
    register short temp    = crc;
    while (--counter >= 0)
        if (temp & 0x8000) {
            temp <<= 1;
            temp += (((ch <<= 1) & 0x0100) != 0);
            temp ^= 0x1021;
        }
        else {
            temp <<= 1;
            temp += (((ch <<= 1) & 0x0100) != 0);
        }
    return(temp);
}
```

Example 3 contains an example of UPDCRC that does require a lookup table.

```
#define updcrc(cp, crc)( crctab[((crc >> 8) & 255)]^ (crc << 8) ^ cp
static unsigned short crctab [256] = {
0x0000, 0x1021, 0x2042, 0x3063, 0x4048, 0x50a5, 0x60c6, 0x70e7,
0x8108, 0x9129, 0xa14a, 0xb16b, 0xc18c, 0xd1ad, 0xe1ce, 0xf1ef,
0x1231, 0x0210, 0x3273, 0x2252, 0x52b5, 0x4294, 0x72f7, 0x62d6,
0x9339, 0x8318, 0xb37b, 0xa35a, 0xd3bd, 0xc39c, 0xf3ff, 0xe3de,
0x2462, 0x3443, 0x0420, 0x1401, 0x64e6, 0x74c7, 0x44a4, 0x5485,
0xa56a, 0xb54b, 0x8528, 0x9509, 0xe5ee, 0xf5cf, 0xc5ac, 0xd58d,
0x3653, 0x2672, 0x1611, 0x0630, 0x76d7, 0x66f6, 0x5695, 0x46b4,
0xb75b, 0xa77a, 0x9719, 0x8738, 0xf7df, 0xe7fe, 0xd79d, 0xc7bc,
0x48c4, 0x58e5, 0x6886, 0x78a7, 0x0840, 0x1861, 0x2802, 0x3823,
0xc9cc, 0xd9ed, 0xe98e, 0xf9af, 0x8948, 0x9969, 0xa90a, 0xb92b,
0x5af5, 0x4ad4, 0x7ab7, 0x6a96, 0x1a71, 0x0a50, 0x3a33, 0x2a12,
0xdbfd, 0xcbdc, 0xfbbf, 0xeb9e, 0x9b79, 0x8b58, 0xbb3b, 0xab1a,
0x6ca6, 0x7c87, 0x4ce4, 0x5cc5, 0x2c22, 0x3c03, 0x0c60, 0x1c41,
0xedaе, 0xfd8f, 0xcdec, 0xddcd, 0xad2a, 0xbd0b, 0x8d68, 0x9d49,
0x7e97, 0x6eb6, 0x5ed5, 0x4ef4, 0x3e13, 0x2e32, 0x1e51, 0x0e70,
0xff9f, 0xefbe, 0xdfdd, 0xcffc, 0xbf1b, 0xaf3a, 0x9f59, 0x8f78,
0x9188, 0x81a9, 0xb1ca, 0xa1eb, 0xd10c, 0xc12d, 0xf14e, 0xe16f,
0x1080, 0x00a1, 0x30c2, 0x20e3, 0x5004, 0x4025, 0x7046, 0x6067,
0x83b9, 0x9398, 0xa3fb, 0xb3da, 0xc33d, 0xd31c, 0xe37f, 0xf35e,
```

## Multiprotocol Rail Reader System Guide

```
0x02b1, 0x1290, 0x22f3, 0x32d2, 0x4235, 0x5214, 0x6277, 0x7256,  
0xb5ea, 0xa5cb, 0x95a8, 0x8589, 0xf56e, 0xe54f, 0xd52c, 0xc50d,  
0x34e2, 0x24c3, 0x14a0, 0x0481, 0x7466, 0x6447, 0x5424, 0x4405,  
0xa7db, 0xb7fa, 0x8799, 0x97b8, 0xe75f, 0xf77e, 0xc71d, 0xd73c,  
0x26d3, 0x36f2, 0x0691, 0x16b0, 0x6657, 0x7676, 0x4615, 0x5634,  
0xd94c, 0xc96d, 0xf90e, 0xe92f, 0x99c8, 0x89e9, 0xb98a, 0xa9ab,  
0x5844, 0x4865, 0x7806, 0x6827, 0x18c0, 0x08e1, 0x3882, 0x28a3,  
0xcb7d, 0xdb5c, 0xeb3f, 0xfb1e, 0x8bf9, 0x9bd8, 0xabbb, 0xbb9a,  
0x4a75, 0x5a54, 0x6a37, 0x7a16, 0x0af1, 0x1ad0, 0x2ab3, 0x3a92,  
0xfd2e, 0xed0f, 0xdd6c, 0xcd4d, 0xbdaa, 0xad8b, 0x9de8, 0x8dc9,  
0x7c26, 0x6c07, 0x5c64, 0x4c45, 0x3ca2, 0x2c83, 0x1ce0, 0x0cc1,  
0xef1f, 0xff3e, 0xcf5d, 0xdf7c, 0xaf9b, 0xbfba, 0x8fd9, 0x9ff8,  
0x6e17, 0x7e36, 0x4e55, 0x5e74, 0x2e93, 0x3eb2, 0x0ed1, 0x1ef0,  
};
```

Example 4 shows an example of a function that creates the lookup table.

```
#include <stdio.h>  
  
#define MAX_CHAR      256  
#define BITS_CHAR     8  
#define SIGN_BIT     0x8000  
#define POLY         0x1021  
unsigned short crctab [MAX_CHAR];  
main ()  
{  
    unsigned short ch;  
    unsigned short workval;  
    unsigned short bit;  
    unsigned short carry;  
    for (ch = 0; ch != MAX_CHAR; ch++) {  
        workval = ch << BITS_CHAR;  
        for (bit = BITS_CHAR; bit != 0; bit--) {  
            carry = (workval & SIGN_BIT);  
            workval <<= 1;  
            if (carry)  
                workval ^= POLY;  
        }  
        crctab[ch] = workval;  
    }  
    for (ch = 0; ch != MAX_CHAR; ch++)  
        printf("0x%04x\n", crctab[ch]);  
}
```

## Manually Disabling ECP for Maintenance

---

Under certain conditions, communications between the host and MPRR may be lost temporarily and maintenance may be required. The reader or host is sending out a message and waiting for an acknowledgment. When the acknowledgment is not received, the message is sent again. Additional messages are also buffered. Often the first indication that the MPRR software is in an ECP “loop” is when the user/technician sees a recurring display of the same message repeated on the monitor. The procedure described in the following paragraphs enables the maintenance technician to change configuration or test tag reading manually.

Assuming that the ECP timeout is at the factory default of 12.7 seconds (or other value that allows enough time for the commands to be manually entered) the following command sequence may be used to break out of an ECP loop. This command sequence uses four ASCII <`> characters (60 hex) as wild card CRC values.

*Note: The ASCII <`> character (60 hex) is commonly located on the ~ key.*

You must acknowledge existing messages by issuing commands with the generic format:

```
#x@` `` ` ` <eom>
```

where

#	Start-of-message character
x	Message sequence number. This must be the same as the sequence number of the message being acknowledged
@	ACK (acknowledgment character)
<` `` ` ` >	Wild card CRC value for the message
<eom>	End-of-message character

The following is a typical sequence after power-on limiting buffered messages.

*Note: Ensure that no tags are in the field when you are performing this troubleshooting procedure.*



### Caution

*To avoid damage to the MPRR, ensure that you have connected the antenna or a dummy load to the reader before applying power to the reader.*

Reader transmission on power-up:

```
#0 Model ... SN <crc><eom>
```

Manually enter: #0@` `` ` ` <eom>

Reader transmission #2 Copyright 2008 TransCore <crc><eom>

## ***Multiprotocol Rail Reader System Guide***

Manually enter: **#2@` `` ` <eom>**

Manually enter: **#101` `` ` <eom>** this puts reader into command mode

Reader response: **#1Done<crc><eom>**

Manually enter: **#3610` `` ` <eom>** this puts reader into basic protocol, disabling ECP

reader response: Done

Enter any other desired diagnostic or directive commands in basic protocol. After maintenance is complete enter the commands:

**#00** to return the reader to data mode

**#611** to return to error correcting protocol

**#100` `` ` <eom>** to return reader to data mode

7

---

## Commands



# Chapter 7

---

## Commands

*This chapter discusses the host-transmitted commands that are used to control the Multiprotocol Rail Reader (MPRR) configuration and operation.*

### **Introduction**

---

The MPRR is delivered from the factory with specified default settings that determine how the reader operates. Commands transmitted by the host device can change the default settings and control additional features. The commands can be transmitted by manually entering the commands at the host keyboard if the host is in terminal emulation mode. The MPRR can also communicate with ASCII terminals.

### **Operating Modes**

---

The MPRR has three modes of operation: data mode, command mode, and download mode. The software for the MPRR contains two separate programs — boot and application. The boot program has control of the MPRR on startup and when operating in download mode. The application program has control of the MPRR during data mode and command mode operation and holds the application code. Together, they control the MPRR in the three modes of operation.

---

#### **Data Mode**

The MPRR is in the data mode upon power-up. While in the data mode, the MPRR sends all communications, such as tag IDs and reports, as data messages to the host device. Reports provide information on input status changes (input0 and input1), a presence without tag report, and buffer overflow information. When MPRR mode has been enabled (#837) and while the MPRR is in data mode, the host device can send the following commands the MPRR:

- Command #01 changes the MPRR from the data mode to the command mode.
- Command #440 provides a one-time reset of all tag uniqueness timers at which point the previously set timeout interval resumes.
- Command #8110 turns on RF port0 and sends the command on Ctag pin 0 to fire off Ctag address 0.
- Command #8111 turns on RF port1 and sends the command on Ctag pin 0 to fire off Ctag address 1.

- Command #8112 turns on RF port2 and sends the command on Ctag pin 1 to fire off Ctag address 0.
- Command #8113 turns on RF Port 3 and sends the command on Ctag pin 1 to fire off Ctag address 1.
- Command #8150 sets the check tag address to 0 on check tag pin 0.
- Command #8151 sets the check tag address to 1 on check tag pin 0.
- Command #8152 sets the check tag address to 0 on check tag pin 1.
- Command #8153 sets the check tag address to 1 on check tag pin 1.

*Note: The MPRR transmits ID codes to the host device when the MPRR is in data mode.*

---

## **Command Mode**

While the MPRR is in the command mode, the host device sends commands to the MPRR that can be used to control the reader operation and configuration. After the MPRR receives a command, it transmits a command response message. Typically, the command message contains `Error`, `Done`, or data relating specifically to the command request. These messages may be of variable length since some commands require information as part of the message; for example, #570 Display Operating Mode Status.

Communication can be lost if the host device attempts to send certain commands under marginal communication conditions. For example, if the host device transmits the command request to change the baud rate and the MPRR properly receives the request and transmits the `Done` message, one of the two following conditions may occur:

1. If the host device receives the `Done` message, then both the host and the MPRR switch to the new baud rate, and communications are maintained.

*Note: In many applications, the host must be set to the new baud rate as it does not change automatically.*

*Note: The MPRR changes the baud rate immediately after issuing the `Done` message.*

2. However, if the host does not receive the `Done` message transmitted by the MPRR, the host assumes that the command was not properly sent and does not switch to the new baud rate, causing a loss of communications.



### **Caution**

*The host device should not attempt to change communications parameters or protocols during marginal communications conditions; otherwise, a loss of communication can result.*



---

## Download Mode

In download mode, the host can download new software to the MPRR.

While in download mode, the reader communications port parameters are fixed at the following factory-default settings: 38400 baud, 8 data bits, 1 stop bit, no parity, software flow control (XON/XOFF), basic protocol.

While in download mode, the MPRR turns RF off, does not process tags, and does not echo host commands.

Typically, TransCore trained personnel download new application code using a custom firmware loader program.

---

## Command List

Reader commands are divided into groups based on a primary function. The following sections provide information about each command in command number order. Refer to Appendix D for listings of commands in numerical and alphabetical order.

In the following text, the symbols < and > represent variable message data. These symbols are not part of the message syntax.

Hex digits (0–9, A–F) in either uppercase or lowercase characters may be used in data strings and for hex digits A–F.

---

## Reader Mode Control — Command Group 0

Group 0 commands control reader mode. The mode determines whether the reader is transmitting data to or receiving data from a host device or terminal.

### 00 Switch to Data Mode (Factory Default)

Command #00 switches the reader to data mode, which allows the reader to transmit tag data (ID codes) to the host. In addition to switching the reader to data mode, command #00 automatically saves to non-volatile memory (NVRAM) any user parameters that had been changed during the command mode session. The reader enters data mode on power up.



#### Caution

*To save user parameter changes to non-volatile memory (NVRAM), you must send command #00 before powering down the reader.*

When MPRR mode has been enabled (#837) and while the MPRR is in data mode, the host device can send the following commands to the MPRR:

- Command #01 Switch to Command Mode

Reader response:

Done

## **Multiprotocol Rail Reader System Guide**

- Command #440 Reset Uniqueness

Reader response:

Done

- Command #8110 Switch on RF Port 0, Fire Off Check Tag Address 0 on Check Tag Pin 0

Reader response:

Done

- Command #8111 Switch on RF Port 1, Fire Off Check Tag Address 1 on Check Tag Pin 0

Reader response:

Done

- Command #8112 Switch on RF Port 2, Fire Off Check Tag Address 0 on Check Tag Pin 1

Reader response:

Done

- Command #8113 Switch on RF Port 3, Fire Off Check Tag Address 1 on Check Tag Pin 1

Reader response:

Done

- Command #8150 Set Check Tag Address to 0 on Check Tag Pin 0.

Reader response:

Done

- Command #8151 Set Check Tag Address to 1 on Check Tag Pin 0.

Reader response:

Done

- Command #8152 Set Check Tag Address to 0 on Check Tag Pin 1.

Reader response:

Done

- Command #8153 Set Check Tag Address to 1 on Check Tag Pin 1.

Reader response:

Done

**Note:** *The MPRR transmits ID codes to the host device when the MPRR is in data mode.*

### 01 Switch to Command Mode

Command #01 switches the reader to command mode, which allows the reader to accept commands from a host or terminal. While in command mode, the reader turns RF off and does not acquire tags.

Reader response:

Done

## Communications Port Control — Command Group 1

Group 1 commands configure the parameters used by the MPRR to communicate with a host device or terminal. These commands set baud rate, stop bits, parity, and end-of-line delay.

### 100N Select Baud Rate

Command #100N selects the reader baud rate. The factory-default setting is 9600 baud. The N variable specifies the baud rate shown in [Table 7-1](#).

**Table 7-1 Select Baud Rate Commands**

Command	Baud Rate Selected
1002	1200
1003	2400
1004	4800
<b>1005</b>	9600 (factory default)
1006	19.2 K
1007	38.4 K



#### Caution

*If ECP is enabled, ensure that the ECP timeout is sufficient for the new baud rate. See “Timing and Synchronization” on page 6-11.*

Reader response:

Done

### 101N Select Stop Bits

Command #101N selects the number of stop bits for reader character transmission. The factory default setting is 1 stop bit. The N variable specifies the number of stop bits as indicated in [Table 7-2](#).

**Table 7-2 Select Stop Bits Commands**

Command	Stop Bits Selected
<b>1010</b>	1 (factory default)
1011	2

Reader response:

Done

### **102N Select Parity**

Command #102N selects the reader parity setting. The factory-default setting is parity disabled. The N variable specifies parity as shown in [Table 7-3](#).

**Table 7-3 Select Parity Commands**

Command	Data Bits	Parity Selected
<b>1020</b>	8	Disable parity (factory default)
1021	7	Select even parity
1022	7	Select odd parity

Reader response:

Done

## **Command Group 2**

Group 2 commands control the real-time clock which maintains the MPRR internal time and date. This time and date can be appended to IDs, error messages, and sensor input reports. An internal battery supports the clock, so time and date are preserved if main power is lost.

### **20 Set Time**

Command #20 sets the time. Enter the time in the proper format: two-digit decimal entries with no spaces between characters and using colons as delimiters.

The entry format is as follows:

*20HH:MM:SS or 20HH:MM:SS:hh*

where

*HH* represents hours (00 to 23).

*MM* represents minutes (00 to 59).

*SS* represents seconds (00 to 59).  
*hh* represents hundredths of a second (00 to 99).  
 : is the time delimiter.

If hundredths of a second is not specified, the reader sets the hundredths register to 00.

Reader response:

Done

### **21 Set Date**

Command #21 sets the date. Enter the date in the proper format: two-digit decimal entries with no spaces between characters and using forward slashes “/” as delimiters. The entry format is as follows:

*21MM/DD/YY*

where

*MM* represents the month (01 to 12).  
*DD* represents the day (01 to 31).  
*YY* represents the last two digits of the year (00 to 99).  
 / is the date delimiter.

Reader response:

Done

### **22 Display Time and Date**

Command #22 displays the reader’s current time and date. One space separates the time and the date output.

Reader response:

*HH:MM:SS.hh MM/DD/YY*

where

*HH* represents hours.  
*MM* represents minutes.  
*SS* represents seconds.  
*hh* represents hundredths of seconds.  
 : is the time delimiter.  
*MM* represents the month.  
*DD* represents the day.  
*YY* represents the last two digits of the year.  
 / is the date delimiter.

## Append Information — Command Group 3

Group 3 commands append useful information to reader transmissions, such as IDs, error messages, and sensor input reports. Auxiliary information such as reader number, antenna number (or manual entry code), number of times the previous tag was read, and sensor input status can be appended to the ID using the Group 3 commands.

### 30N Append Time and Date Selection

Command #30N selects the option of appending the time and date to transmitted IDs, error messages, presence without tag reports, and input status change reports. The factory default setting is time and date appended (command #302).

The reader returns an *Error* message if its tag buffer contains data. The reset reader command #63 may be transmitted to clear the buffer; however, tag ID data will not be reported. If this is unacceptable, allow the buffer to empty before re-issuing append time and date command #30N. Append Time and Date commands are shown in [Table 7-4](#)

**Table 7-4 Append Time and Date Commands**

Command	Append Option
300	No time and date appended
<b>302</b>	Time and date appended (factory default)

The reader transmits messages with time and date appended as follows. One space separates the time from the date.

`<string>&<HH:MM:SS.hh MM/DD/YY>`

where

`string` is a tag ID, error message, or report.

`&` separates `<string>` from the time and date.

`HH:MM:SS` is the time delimiter.

`MM/DD/YY` is the date delimiter.

Reader response:

Done

### 31N Append Auxiliary Information Selection

Command #31N selects the option of appending auxiliary information to transmitted IDs, presence-without-tag reports, and input status change reports. Auxiliary information is not appended to error messages. The factory-default setting is no auxiliary information appended. The N variable specifies whether or not auxiliary information is to be appended. Append Auxiliary Information commands are shown in [Table 7-5](#).

**Table 7-5 Append Auxiliary Information Commands**

Command	Append Option
310	No auxiliary information appended (factory default)
311	Auxiliary information appended

The reader transmits messages with auxiliary information appended as:

`<message data>%<xx-y-zz-q-sss>`

where

- % separates the auxiliary information and signals the host computer that auxiliary information is appended.
- xx reader ID. Value can be set with command #60NN.
- auxiliary information delimiter
- y antenna number.
- zz number of reads (00 to FF hexadecimal) of the previous tag on this antenna
- q current status of input0 and input1 (0 to 3)
- sss relative to tag read strength

*Note: If the MPRR mode is enabled (#837), a relative tag strength used by the Train Recording Unit (TRU™) is appended to the end of the auxiliary data.*

Reader response:

Done

## **ID Filtering — Command Group 4**

Group 4 commands set criteria for filtering (buffering or discarding) ID codes. These commands are useful for eliminating duplicate ID codes and selecting the type of tags read by the MPRR.

### **40 Transmit All ID Codes**

Command #40 instructs the reader to transmit all IDs without regard for uniqueness. This command can be useful when tuning the read zone and mapping the footprint or performing diagnostics.

After diagnostics are complete, you may want to reinstate the uniqueness check using command #410N Select Unique ID Code Criteria.

Reader response:

Done

**410N Select Unique ID Code Criteria (Anti-passback Feature)**

Command #410N instructs the reader to buffer and transmit ID codes according to the following test: an ID is read if previously decoded IDs have changed value at least N+1 times since the new ID was last received. IDs that do not pass the test are not reported. The factory-default setting is command #4100, which selects a separation of one ID. Variable N specifies ID separation as shown in [Table 7-6](#).

**Table 7-6 Unique ID Code Criteria**

Command	Uniqueness Criteria
4100	Separation of 1 ID (factory default)
4101	Separation of 2 IDs
4102	Separation of 3 IDs
4103	Separation of 4 IDs

Each time the reader receives a tag ID, it compares the ID with the contents of a comparison register. This register contains the following two items:

- Item 1            Most recently acquired ID
- Item 2            Second-most recently acquired ID
- Item 3            Third-most recently acquired ID
- Item 4            Fourth-most recently acquired ID

When the uniqueness filter is set to separation of one ID, the newly acquired ID is transmitted only if it is different from the first item. Separation of two IDs allows transmission if the new ID is different from Items 1 and 2 in the comparison register. Separation of three and four IDs transmit the new ID only if it is different from the first three and the first four items, respectively.

*Note: A new ID can fail the filter test and not be transmitted; however, it remains stored in the comparison register.*

The uniqueness test has a time limit as set by command #44N. If an ID is buffered, it will not be accepted again unless it arrives at the reader more than the timeout value from the previous arrival or until the receipt of one or more other IDs reset the uniqueness.

Reader response:

Done



### 420N Select Valid ID Code Criteria

Command #420N directs the reader to validate an ID received only after it has been obtained a specified number of times in sequence. Values for N are 1 through 4 (Table 7-7). The factory setting is one acquisition (N = 0).

**Table 7-7 Select Valid Code Commands and Frames**

Command	Valid Code Frames
<b>4200</b>	1 (factory default)
4201	2
4202	3
4203	4

The validation procedure is executed before the unique ID test (Select Unique ID Code Criteria [#410N] commands). IDs that do not pass the validation test are not reported.

For example, command #4203 specifies that the same ID must be obtained from the antenna/RF module 4 times in succession before it is considered for the uniqueness test. This feature is useful in installations where RF reflections may cause a single tag to be read multiple times or where an occasional ID might be read from fringe areas

### 440 Reset Uniqueness

Command 440 causes the ID filtering process set by Select Unique ID Code Criteria (#410N) to restart. It is used in conjunction with the Set Uniqueness Timeout #44N commands. This command provides a one-time reset at which point the previously set timeout interval resumes. This command can be sent in data or command mode.

### 44N Set Uniqueness Timeout

Places a time limit on the uniqueness criterion set by Select Unique ID Code Criteria (#410N). The parameter N sets the number of minutes on the timeout clock. The factory setting is two minutes (N = 1).

**Command    Timeout Clock**

- #441        2 minutes (*factory setting*)
- #442        15 seconds
- #443        30 seconds

Entering these commands effectively expires the timeout clock, which erases all current IDs in the comparison register. In effect, the first ID that is acquired after the clock expires always appears to be new and is stored. Newly acquired IDs are only tested against IDs that are registered after the clock resets.

The timeout clock is continually reset (does not expire) as long as the reader receives the same tag ID. For example, assume that the timeout clock is set for two minutes and there is a railcar parked on a siding in front of the reader. Without this reset feature, the railcar's ID would be reported every two minutes (each time the timeout clock expired).

### **452 Disable Tag Translation Mode (Factory Default)**

Command #452 disables tag translation mode. Incoming full-frame tags will be converted directly to ASCII. They will not be translated from Association of American Railroads (AAR) and American Trucking Associations (ATA) format to ASCII.

Reader response:

*Done*

### **453 Enable Tag Translation Mode**

Command #453 enables the translation of tags in AAR and ATA formats. Specific data fields, such as owner ID and car number, will be extracted from these tags, translated according to AAR or ATA standards, and converted to ASCII. Tags that are not programmed in AAR or ATA format will be converted directly to ASCII. The reader will not attempt to translate data from half-frame or dual-frame tags.

Reader response:

*Done*

### **456 Enable SeGo Protocol Tag Initialization During Multi-tag Sort (Factory Default)**

Command #456 enables the reader to send the Super eGo<sup>®</sup> (SeGo) protocol tag initialize command as part of the multi-tag sort function. When the reader sends the SeGo protocol tag initialize command, all tags in the RF field reenter the sort process.

Reader response:

*Done*

### **457 Disable SeGo Protocol Tag Initialization During Multi-tag Sort**

Command #457 disables the reader from sending the SeGo protocol tag initialize command as part of the multi-tag sort function. Any SeGo protocol tags already identified by the reader during the sort process will not be re-identified as long as they remain powered in the RF field. The reader will only identify new tags that come into the RF field or tags that do not remain powered in the RF field.

Reader response:

*Done*

### **480 Disable ATA**

Command #480 disables the reader from reading ATA protocol tags.

**481 Enable ATA**

Command #481 enables the reader to read ATA protocol data from tags *if the reader is programmed to read this tag protocol.*

**484 Disable SeGo**

Command #484 disables the reader from reading SeGo protocol data from tags.

**485 Enable SeGo**

Command #485 enables the reader to read SeGo protocol data from tags *if the reader is programmed to read this tag protocol.*

**488 Disable eATA**

Command #488 disables the reader from reading factory-programmed eATA data from tags.

**489 Enable eATA**

Command #489 enables the reader to read factory-programmed eATA data from SeGo protocol tags.

**Reader Status — Command Group 5**

Group 5 commands provide status reports on the parameters and operation of the reader.

**505 Display Software Version**

Command #505 displays the reader model number, software version information, and assigned serial number.

Reader response:

Model E4 Series Ver X.XX SNSSSSSS

where

X.XX                      Version number

SSSSSS                  Serial number of the unit, skipping the fourth character printed on the reader product label

**506 Display Hardware Configuration Information**

Command #506 displays hardware configuration information stored in the reader memory by the user. Hardware configuration information is empty by default until you set the information to any 20 character ASCII string desired using command #696S . . . S.

Reader response:

*An ASCII string from 1 to 20 characters in length*

### **520 Display Power Fail Bit**

Command #520 displays the value of the reader power fail bit. The power fail bit changes from 0 to 1 when power to the reader is interrupted. To reset the bit, use command #63 Reset Reader or command #65 Reset Power Fail Bit. On initial power-up, the host should transmit one of these two commands to clear the power fail bit.

Reader response:

PWRB P<0 to 1> R0

where

P0	No power failure detected
P1	Power failure detected
R0	Not applicable to the MPRR

### **521 Display Reader ID Number**

Command #521 displays the reader ID that is sent in the auxiliary data field.

Reader response:

RDID xx

where xx = 01 to FF (hexadecimal)

### **522 Display Communications Port Parameters**

Command #522 displays the selected communications port parameters, including the baud rate (#100N), the number of stop bits (#101N), the parity scheme (#102N), and the end-of-line delay.

Reader response:

MAIN B<2 to 7> S<0 to 1> P<0 to 2> D0

where

B2	1200 baud
B3	2400 baud
B4	4800 baud
B5	9600 baud (factory default)
B6	19.2 kbps
B7	38.4 kbps
S0	one stop bit (factory default)
S1	two stop bits

P0 no parity (factory default)  
 P1 even parity  
 P2 odd parity

D0 00 ms end-of-line delay (fixed)

One space is required between each value. For example, if factory default settings are assigned, the reader message is

```
MAIN B5 S0 P0 D0
```

indicating 9600 baud, one stop bit, no parity, and 0-ms end-of-line delay.

*Note: The information transmitted in response to command #522 applies to data and command mode operation only. While operating in download mode, default communications parameters are always used.*

### 524 Display Appended Information Status

Command #524 displays the information being appended to the reader transmissions. Command #31N appends information.

Reader response:

```
IDAP T<0 to 1> D<0 to 1> X<0 to 1>
```

where

T0 Time not appended  
 T1 Time appended  
 D0 Date not appended  
 D1 Date appended  
 X0 Auxiliary information not appended (factory default)  
 X1 Auxiliary information appended

One space is required between each value. For example, if factory-default settings are assigned, the reader response is

```
IDAP T1 D1 X0
```

indicating time and date appended, and auxiliary information not appended.

### 525 Display Communications Protocol Status

Command #525 displays the status of command #610 Select Basic Communications Protocol, command #611 Select Error Correcting Protocol, or #613 Enable Data Inquiry Protocol, command #614N Selected Mode of Flow Control, and command #612NN Error Correcting Protocol Timeout.

Reader response:

```
ECPS P<0 to 2> T<01 to FF> X<0 to 2> S0
```

where

P0	Basic protocol selected (factory default)
P1	ECP enabled
P2	data inquiry protocol enabled
Txx	ECP timeout where xx = 01 to FE (hexadecimal) Timeout (ms) = 50 * xx If xx = FF timeout disabled
X0	Flow control disabled
X1	Software flow control enabled (factory default)
X2	Hardware flow control enabled
S0	start of message character is #

For example, if factory default settings are assigned, the reader message is:

```
ECPS P0 TFE X1 S0
```

which means basic protocol selected, an ECP timeout of 254 (12,700 ms or 12.7 sec), software flow control enabled, and start of message character is #.

### **527 Display RF Status**

Command #527 displays the current status of the RF module. The reader response indicates whether RF is controlled externally by the host, set by command #640N RF Control, or internally by input set by command #641 (not applicable to the MPRR). RF always is controlled by Sense0 and Sense1 when reader is in MPRR mode. Sense0 enables RF on antenna ports 0 and 1, and Sense1 enables RF on antenna ports 2 and 3. See [“MUX Operational Modes” on page 7-38](#). Command #527 also displays the current RF status and the uniqueness timeout.

*Note: If you enter RF settings using command #642NN, the display command for RF output frequency, F is “Fxx” and indicates use of the backward-compatible frequency entry method.*

Reader response:

```
RFST C<0 to 1> O<0 to 1> T<1 to 3> Fxxx Rxx Gxx Axx Ixx
```

where

C0	RF controlled by host
C1	RF controlled by presence sensor on input0, the red/green pair (factory default)
O0	RF off
O1	RF on
T1	Uniqueness timeout of two minutes

T2	Uniqueness timeout of 15 seconds
T3	Uniqueness timeout of 30 seconds
Fxxx	RF output frequency, xxx = 000 to 118 hexadecimal offset in 250 kHz from 860 MHz. If an invalid frequency value is stored (corrupted NVRAM), then xxx = “XXX” to indicate an error in the frequency setting.
Rxx	Tag decoder range (distance) for ATA tags, xx = 00 to 1F hexadecimal range value
Gxx	Tag decoder range (distance) for SeGo protocol tags, xx = 00 to 1F hexadecimal range value
Axx	RF power attenuation, where 00 is maximum output power and 0A is minimum output power (10dB less than maximum power).
I04	Fixed

For example, if factory default settings are assigned, the reader message is

```
RFST C1 00 T1 Fxxx R1F G1F A00 I04
```

which means that RF is enabled by presence sensor on input0, RF signal off, uniqueness timeout of two minutes, RF output frequency has not been set, maximum RF output range for ATA tags, maximum RF output range for eGo and eGo Plus tags, full RF power, and IAG power set at 4 dB attenuation.

### **529 Display Presence Input Status**

Command #529 displays the parameters associated with presence detection and RF control. The reader’s message indicates if presence without tag reports are enabled/disabled (#690N Select Presence without Tag Report Option), if input inversion is enabled/disabled (#694N Select Input Inversion Option), and the minimum presence true period (always true). The reader’s message also reports the selected RF timeout (#693N Select RF Timeout Period) and the selected means of RF-off control (#692N Select RF Control Algorithm). If presence without tag reports is enabled (#6901 Enable Presence without Tag Report Option), the reader transmits a report if a presence is detected without the subsequent acquisition of a valid tag.

*Note: RF timeout values vary depending on the operative tag read mode and the type of tag in the read field. All times are approximate.*

Reader response:

```
PRST P<0 to 1> D0 A<0 to 2> T<0 to F> I<0 to 1>
```

where

P0	Presence without tag reports disabled (factory default)
P1	Presence without tag reports enabled

## **Multiprotocol Rail Reader System Guide**

D0	Minimum presence true period of 0 ms (fixed)
A0	RF off on timeout only
A1	RF off on timeout or tag
A2	RF off on timeout or presence condition false (factory default)
T0	RF timeout of 0 ms (always expired)
T1	4 ms
T2	8 ms
T3	12 ms
T4	20 ms
T5	24 ms
T6	32 ms
T7	48 ms
T8	60 ms
T9	92 ms
TA	152 ms
TB	300 ms
TC	452 ms
TD	600 ms
TE	752 ms
TF	RF timeout infinite, never expires (factory default)
I0	input inversion disabled (factory default)
I1	input inversion enabled

For example, if factory default settings are assigned, the reader message is

```
PRST P0 D0 A2 TF I0
```

which means that presence without tag reports is disabled, minimum presence true period is 0, RF off control on timeout or presence false, infinite RF timeout, and input inversion disabled.



### 530 Display RF0 Filter Status

Command #530 displays the parameter set for the RF input, including the selected unique ID code criteria (#410N Select Unique ID Code Criteria) and the valid ID code criteria, which are fixed at one acquisition.

Reader response:

RF0S U<0 to 4> V<0 to 3>

where

U0	One ID separation (factory default)
U1	Two ID separations
U2	Three ID separations
U3	Four ID separations
U4	Transmit all IDs
V0	Valid ID code criteria of one acquisition (factory default)
V1	Valid ID code criteria of two acquisitions
V2	Valid ID code criteria of three acquisitions
V3	Valid ID code criteria of four acquisitions

For example, if factory default settings are assigned, the reader message is

RF0S U0 V0

which means separation of one ID for uniqueness filtering and a valid ID code criteria of one acquisition.

### 534 Display Tag Translation Mode Status

Command #534 displays tag translation mode status, enabled or disabled. If tag translation mode is enabled, incoming full-frame tags in AAR or ATA format are translated according to ISO standards. Refer to [“452 Disable Tag Translation Mode \(Factory Default\)”](#) on page 7-14 and [“453 Enable Tag Translation Mode”](#) on page 7-14 for more information.

Reader response:

TT <0 to 1>

where

0	tag translation mode disabled
1	tag translation mode enabled

### **537 Display Echo Status**

Command #537 displays echo mode status. In basic protocol (#610 Select Basic Communication Protocol) and data inquiry protocol (#613 Enable Data Inquiry Protocol), the reader may be configured to enable (#6171 Enable Echo Mode) or disable (#6170 Disable Echo Mode) the echo of received commands. Refer to sections [6170 Disable Echo Mode](#) and [“6171 Enable Echo Mode \(Factory Default\)” on page 7-26](#) for more information.

Reader response:

```
ECHO <0 to 1>
```

where

0 Echo status disabled (factory default)

1 Echo status enabled

### **540 Display Flash Checksum**

Command #540 displays the flash memory checksum.

Reader response:

```
PCKS I0000 Exxxx
```

where

0000 Not applicable to the MPRR

xxxxx Represents the four-byte ASCII representation of the flash memory checksum

### **543 Display Boot Checksum**

Command #543 displays the boot ROM checksum.

Reader response:

```
BCKS xxxx
```

where xxxx represents the four-byte ASCII representation of the boot ROM checksum.

### **549 Get User-Programmable Group Select Equals (GSE) Filter Data**

Command #549 queries the reader for the user-programmable GSE filter data programmed in the reader using command #697. The response data is formatted similar to the data in the configuration command.

For example, if the command string shown in command #697 (see [“697 Set User-Programmable Group Select Equals \(GSE\) Filter” on page 7-34](#)) was sent to a given reader, the response to the #549 query command would be:

```
#A4 0A 0005014202024133
```

The reader response contains all the data fields repeated in the same sequence as displayed in the User-Programmable GSE configuration command.

### 552 Display Antenna Multiplexing Mode

Command #552 displays the antenna multiplexing mode. When the MPRR mode is enabled, the response is

Reader response:

MUX x<0 to 3> <MPRR>

where

x = 0 antenna multiplexing disabled, RF on port 0 only

x = 1 antenna multiplexing between RF ports 0 and 1 when sense0 active

x = 2 antenna multiplexing between RF ports 0 and 1 when sense0 active and RF port 2 when sense1 active

x = 3 antenna multiplexing between RF ports 0 and 1 when sense0 active and RF ports 2 and 3 when sense1 active

MPRR = MPRR mode selected

### 560 Request Sensor Status Change

Command #560 displays the sensor status change reporting. Not applicable to the MPRR

Reader response:

SSTC E<0 to 1> M<0 to 3>

where

E0 Input status change reports disabled (factory default)

E1 Input status change reports enabled

M0 Reporting disabled (factory default)

M1 Changes on input0 reported

M2 Changes on input1 reported

M3 Changes on either input reported

For example, if factory default settings are assigned, the reader message is

SSTC E0 M0

which means that input status change reports are disabled on both input0 and input1.

### 570 Display Operating Mode Status

Command #570 displays the currently selected tag read mode.

Reader response:

ATA:<E, D> eGo:<I, F, D> SeGo:<I, F, D> IAG:<E, D> Sort:<E, D> TMM0

where

I	ID (64 bits)
E	Enabled
F	Full transaction (eATA)
D	Disabled
TMM0	Fixed

### **577 Report Buffered Handshakes**

Command #577 reports the buffered handshakes. When in MPRR mode and/or if antenna multiplexing is enabled, the response is

Reader response:

```
HDSH C0 <ww> C1 <xx> C2 <yy> C3 <zz>
```

where

ww	count from port 0
xx	count from port 1
yy	count from port 2
zz	count from port 3.

---

## **Reader Control Functions — Command Group 6**

Group 6 commands set reader control functions such as reader ID, communication protocol, output pulse, and RF control.

### **60NN Set Reader ID Number**

Command #60NN sets the reader ID that will be sent in the auxiliary data field (command #311). Uppercase or lowercase characters are allowed for NN; for example, hex digits A through F or a through f

where NN = 00 to FF (hex for 0 to 255, factory default = 00).

Reader response:

```
Done
```

### **610 Select Basic Communication Protocol (Factory Default)**

Command #610 enables the basic communications protocol.

Reader response:

```
Done
```

### **611 Select Error Correcting Protocol**

Command #611 enables the error correcting protocol.

Reader response:

```
Done
```



**Caution**

*Do not switch to ECP (command #611 Select Error Correcting Protocol) unless the host is prepared to acknowledge each reader transmission.*

**612NN Select Error Correcting Protocol Timeout**

Command #612NN selects the timeout interval for ECP. This timeout applies to the transmission of tag, report, and error messages and to the receipt of host commands. The transmit timeout is initiated immediately after the end-of-message sequence CR/LF is transmitted. If the host does not acknowledge the message within the specified interval, the reader times out and retransmits the message.

The receive timeout is initiated upon receipt of the start-of-message character (#). If the end-of-message character (CR) is not received within the specified interval, the reader discards the partially received message and resets its receiver.

Uppercase or lowercase characters are allowed for NN; for example, hex digits A through F or a through f.

The value for NN specifies the timeout interval as follows:

ms	50 * NN for NN = 01 to FE (1–254)
FE	Factory default (12,700 ms or 12.7 seconds)
FF	Disables the ECP timeout

Reader response:

Done



**Caution**

*Ensure that the ECP timeout is sufficient for a given baud rate. See “Timing and Synchronization” on page 6-11.*

**613 Enable Data Inquiry Protocol**

Command #613 enable the data inquiry protocol. Refer to “Data Inquiry Protocol” on page 6-5 for more information.

Reader response:

Done

**614N Select Flow Control Option**

Command #614N selects the flow control option for reader-to-host communications. The factory default setting is software flow control (XON/XOFF) enabled. In download mode, flow control is not host-selectable; it is fixed at the default setting. However, during data mode and command mode operation, the following flow control options are available. The N variable specifies flow control as shown in Table 7-8.

**Table 7-8 Flow Control Commands**

Command	Flow Control Option
6140	Disable flow control
<b>6141</b>	Enable software flow control (factory default)
6142	Enable hardware flow control

Reader response:

Done

If the reader is configured for software flow control (XON/XOFF), it stops transmitting if it receives an XOFF character (host software command 13H). It does not resume transmitting until it receives an XON character (host software command 11H). If the reader is configured for hardware flow control (RTS/CTS, request to send/clear to send), it stops transmission if it detects that the CTS line is no longer asserted. It resumes transmission when this line is asserted again.

*Note: TransCore recommends that XON/XOFF flow control be disabled while using the ECP.*

### **6170 Disable Echo Mode**

Command #6170 disables the reader's echo of received host commands. If operating in basic protocol or data inquiry protocol, the reader echoes by default. As the reader receives a host command, it echoes each character of the command. Once the entire command has been received and processed, the reader transmits its response. If echoing is disabled with command #6170, the reader does not echo the command, but only transmits its response. The reader never echoes while in ECP or download mode operation.

Reader response:

Done

### **6171 Enable Echo Mode (Factory Default)**

Command #6171 enables the reader to echo received host commands. Command #6170 disables echo mode.

Reader response:

Done

### **63 Reset Reader**

Command #63 resets the power fail bit, clears all buffers, resets tag uniqueness, turns off both output lines, transmits the sign-on message, and returns to the data mode.

*Note: This command does not reset any other configuration parameters.*

Reader response:

```
Model E4 Series Ver X.XX SNSSSSSS
Copyright 2008 TransCore
```

where

X.XXD           Version number

SSSSSS           Serial number of the unit, skipping the fourth character printed on the reader product label.

### 640N RF Control

Command #640N directly controls the RF module. The N value controls the RF power as shown in [Table 7-9](#).

*Note:* These commands only have an effect when the reader is not in MPRR mode. See commands #836 and #837.

**Table 7-9 RF Control Commands**

Command	RF Power
6400	Turns off RF
6401	Turns on RF

Command #6400 disables RF-by-input control command #641 Select RF-by-Input Control.

Reader response:

Done

### 641 Select RF-by-Input Control (Factory Default)

Command #641 configures the reader for RF-by-input control. The reader automatically turns on RF when it detects a presence through sense0. The reader turns off RF according to the selected RF control algorithm (#692N Select RF Control Algorithm).

*Note:* This command only has an effect when the reader is not in MPRR mode.

Reader response:

Done

### 643NN Select ATA Operating Range (Distance)

Command #643NN selects the read range for ATA tags where NN is a hexadecimal value from 00 to 1F; the range increases with increasing NN value. The range can be adjusted for 32 discrete values where 00 is the shortest range and 1F is the longest range. The default range value is 1F.

Reader response:

Done

### 644NN Set RF Attenuation

Command #644NN sets the attenuation control for the output RF power where NN is a hexadecimal value from 00 to 0A. Settings for attenuation are 1.0 dB increments over a range of 10 dB of attenuation from the maximum power setting of 2 watts at 0-dB attenuation to a minimum power level of 200 milliwatts at 10-dB attenuation.

The Set RF Attenuation command NN variables and corresponding attenuation settings are shown in [Table 7-10](#).

**Table 7-10 RF Attenuation Command Variables**

Variable (NN)	Attenuation Setting (dB)
00	0 (factory default)
01	1
02	2
03	3
04	4
05	5
06	6
07	7
08	8
09	9
0A	10

Reader response:

Done

### 645NN Set SeGo Protocol Operating Range (Distance)

Command #645NN sets the read range for SeGo protocol tags where NN is a hexadecimal value from 00 to 1F; the range increases with increasing NN value. The range can be adjusted for 32 discrete values where 00 is the shortest range and 1F is the longest range. The default range value is 1F.

Reader response:

Done



**647XXX Select RF Operating Frequency**

Command #647XXX sets the reader RF from 860 to 930 MHz in 250-kHz steps, where XXX is a hexadecimal value from 000 to 118. After the reader’s frequency is set, the value is stored in NVRAM. This value is not altered by power-down.

If the NVRAM becomes corrupted, the correct operating frequency cannot be guaranteed. In this circumstance, the RF section shuts down and the reader sends an Error06 message to the host. Until the frequency is reset using command #647XXX, the unit displays the same error message each time it is powered up or if an attempt is made to enable the RF by host or by external sensor.

The commands to set the RF frequency are presented in [Table 7-11](#).

**Table 7-11 Select RF Frequency Commands**

Command	RF Frequency (MHz)
647000	860.00
.	.
.	.
.	.
6470CF	911.75
6470D0	912.00
6470D1	912.25
6470D2	912.50
6470D3	912.75
6470D4	913.00
.	.
.	.
.	.
6470EA	918.50
6470EB	918.75
6470EC	919.00
6470ED	919.25
6470EE	919.50
6470EF	919.75
.	.
.	.

**Table 7-11 Select RF Frequency Commands (continued)**

Command	RF Frequency (MHz)
657113	928.75
647114	929.00
647115	929.25
647116	929.50
647117	929.75
647118	930.00

Reader response:

Done

### **65 Reset Power Fail Bit**

Command #65 resets the power fail bit to 0. The bit changes from 0 to 1 when power is restored to the reader. Upon reader power-up, the host transmits either command #65 or #63 Reset Reader to properly initialize this bit. The current state of the power fail bit may be displayed. Refer to [“520 Display Power Fail Bit” on page 7-16](#) for more information.

Reader response:

Done

### **66F Load Default Operating Parameters**

Command #66F loads all the factory default operating parameters except RF operating frequency. Refer to [Table 8-1, MPRR Default Configuration Settings](#) for a listing of the defaults.

Reader response:

Done      All parameters loaded OK  
 Error     A parameter load failed

### **690N Select Presence Without Tag Report Option**

Command #690N enables or disables the presence without tag report option. If the presence without tag reporting option is enabled using command #6901, input reports are transmitted when a tag presence is detected without the subsequent acquisition of a valid tag. The value for N specifies the reports as shown in [Table 7-12](#).

*Note:* These commands only have an effect when the reader is not in MPRR mode.

**Table 7-12 Presence Without Tag Report Commands**

Command	Report Option
<b>6900</b>	Disable presence without tag reports (factory default)
6901	Enable presence without tag reports

Reader response:

Done

Refer to “Basic Protocol and ECP Format” on page 6-5 for message format information.

**692N Select RF Control Algorithm**

Command #692N selects the algorithm for turning off RF power when RF-by-input control is enabled using command #641 Select RF-by-Input Control.

The values for N specify the RF control algorithms as shown in Table 7-13.

*Note: These commands only have an effect when the reader is not in MPRR mode.*

**Table 7-13 RF Control Algorithm Commands**

Command	RF Power Off
6920	On timeout only
6921	Timeout or tag ID acquired
<b>6922</b>	Timeout or presence false (factory default)

Command #6920 turns off RF power based on the timeout established by command #693N Select RF Timeout Period.

Command #6921 allows RF power to be turned off either after the timeout period or upon acquisition of a valid tag ID, whichever occurs first.

Command #6922 turns off RF power either after the timeout period or upon the presence false condition, whichever occurs first.

Reader response:

Done

**693N Select RF Timeout Period**

Command #693N selects the RF timeout period used by command #692N Select RF Control Algorithm. Values for N range from 0 through F.

Command #693F disables the RF timeout. The reader turns off the RF immediately following the acquisition of a valid tag, whether or not it is unique.

Uppercase or lowercase characters are allowed for N; for example, hex digits A through F or a through f. The commands and corresponding timeouts are shown in [Table 7-14](#).

**Table 7-14 Timeout Period Values**

Command	Timeout (ms)
6930	0 (always expired)
6931	4
6932	8
6933	12
6934	20
6935	24
6936	32
6937	48
6938	60
6939	92
693A	152
693B	300
693C	452
693D	600
693E	752
<b>693F</b>	Infinite (never expires, factory default)

Reader response:

Done or Error.

The reader returns an `ERROR` message if a valid hexadecimal digit is not substituted for N in command #693N.

*Note:* This command only has an effect when the reader is not in MPRR mode.

### **694N Select Input Inversion Option**

Command #694N enables or disables input inversion. When inversion is enabled, an open circuit input is interpreted as a closed circuit, and a closed circuit input is interpreted as an open circuit. This feature allows greater flexibility in the attachment of external equipment to the reader inputs. For example, some proximity sensors indicate presence with an open circuit. In this instance, command #6941 can enable input inversion so that an open circuit input indicates a presence. The values for N represent the two inversion options as shown in [Table 7-15](#).

**Table 7-15 Input Inversion Options**

Command	Option
6940	Disable input inversion (factory default)
6941	Enable input inversion

Reader response:

Done

**695S...S Set Serial Number (Factory Default)**

Command #695 assigns the reader serial number according to the format:

695SSSSSS

where SSSSSS is the serial number.

The serial number may contain as many as six uppercase or lowercase ASCII alphanumeric characters.

*Note: The factory-assigned serial number of the reader contains seven characters. However, to maintain backward compatibility, the reader software allows only six characters to be entered. When setting the serial number, skip the fourth (middle) character of the seven-character number shown on the reader product label.*

*Note: Once assigned, the serial number is preserved during power-down and the loading of default parameters.*

Reader response:

Done

**696S...S Store Hardware Configuration String (Factory Default)**

Command #696S . . . S stores hardware configuration information into reader memory.

The hardware configuration string is assigned according to the following format:

696S . . . S

where S . . . S is the hardware configuration string that may contain as many as 20 uppercase or lowercase ASCII alphanumeric characters.

*Note: Once assigned, configuration information is preserved during power-down and the loading of default parameters.*

Reader response:

Done

## 697 Set User-Programmable Group Select Equals (GSE) Filter

Command #697 sets the user-programmable GSE filter.

The command string is assigned according to the following format:

```
697 MM AA DDDDDDDDDDDDDDDDD
```

where

MM = The tag uses this mask to determine which of the eight Comparison Data bytes are to be compared for the Group Select filter.

AA = This field is used by the tag to determine the start address in the tag memory for the comparison data.

DD...DD = Comparison Data: an 8-byte field (16 characters) used by the tag as the comparison data for the Group Select filter. The tag compares the data in this field to data in tag memory beginning at the Start Address to determine if the tag will respond to a reader Group Select request. Only the bytes having the corresponding bit set in the GSE Mask is used for this comparison.

As an example, to configure a reader to have only tags with data in byte locations 10, 12, and 15 (decimal) with hexadecimal values “00,” “01,” and “02,” the following command is used:

```
#697 A4 0A 0005014202024133
```

To understand how the data is interpreted, it is necessary to break down the GSE Mask field, A4, into binary:

A4 = **1010** 0**100**

This mask equates to the tag comparing the first, third, and sixth bytes of the Comparison Data to data in the tag beginning at address location 0A (10 decimal).

The Comparison Data field is broken down in bytes with the bytes corresponding to the mask underlined in bold (for clarification):

```
Address: 0A 0B 0C 0D 0E 0F 10 11  
Data: 00 05 01 42 02 02 41 33
```

where

**0A** (10 decimal) must be equal to “00” hexadecimal, the first byte in the Comparison Data field

**0C** (12 decimal) must be equal to “01” hexadecimal, the third byte in the Comparison Data field

**0F** (15 decimal) must be equal to “02” hexadecimal, the sixth byte in the Comparison Data field

Reader response:

```
Done
```

---

## ***Auxiliary Reader Control — Command Group 8***

Group 8 commands provide control of reader functions, such as the sense input lines.

### ***8110 Switch on RF Port 0, Fire Off Check Tag Address 0 on Check Tag Pin 0***

Command #8110 turns on RF Port 0 and sends the command on Ctag pin 0 to fire off Ctag address 0.

### ***8111 Switch on RF Port 1, Fire Off Check Tag Address 1 on Check Tag Pin 0***

Command #8111 turns on RF Port 1 and sends the command on Ctag pin 0 to fire off Ctag address 1.

### ***8112 Switch on RF Port 2, Fire Off Check Tag Address 0 on Check Tag Pin 1***

Command #8112 turns on RF port2 and sends the command on Ctag pin 1 to fire off Ctag address 0.

### ***8113 Switch on RF Port 3, Fire Off Check Tag Address 1 on Check Tag Pin 1***

Command #8113 turns on RF Port 3 and sends the command on Ctag pin 1 to fire off Ctag address 1.

### ***8142X Set Check Tag Character on Check Tag Pin 0***

Command #8142X sends the command on Ctag pin 0 to set the Ctag character.

### ***8143X Set Check Tag Character on Check Tag Pin 1***

Command #8143X sends the command on Ctag pin 1 to set the Ctag character.

### ***8150 Set Check Tag Address to 0 on Check Tag Pin 0***

Command #8150 sets the check tag address to 0 on check tag pin 0.

### ***8151 Set Check Tag Address to 1 on Check Tag Pin 0***

Command #8151 sets the check tag address to 1 on check tag pin 0.

### ***8152 Set Check Tag Address to 0 on Check Tag Pin 1***

Command #8152 sets the check tag address to 0 on check tag pin 1.

### ***8153 Set Check Tag Address to 1 on Check Tag Pin 1***

Command #8153 sets the check tag address to 1 on check tag pin 1.

**830 Disable Automatic Periodic RF Status Report (Factory Default)**

Command #830 is a default set in the factory to disable the automatic periodic RF status report.

Reader response:

Done

**831 Enable Automatic Periodic RF Status Report**

Command #831 enables the automatic periodic RF status report. This function sends out a periodic RF status report if no other message (a tag read) is sent from the reader for a period of time. This message is the same message that would be sent in response to the #527 Display RF Status command. Enabling this function is helpful in some sites where there may not be much tag activity, and the user wants an automatic way to ensure the communication channel with the reader is still intact. With this function enabled, the host system will get a message from the reader at least every three minutes.

Reader response:

Done

**836 Disable MPRR Mode**

Command #836 disables the MPRR mode.

Reader response:

Done

**837 Enable MPRR Mode**

Command #837 enables the MPRR mode.

Reader response:

Done

**850 MUX RF Port 0 (Factory Default)**

Command #850 enables RF Port 0, which disables antenna multiplexing.

Reader response:

Done

**851 MUX Between RF Ports 0 and 1**

Command #851 multiplexes between RF ports 0 and 1.

Reader response:

Done



**852 MUX Between RF Ports 0, 1, and 2**

Command #852 multiplexes between RF ports 0, 1, and 2.

Reader response:

Done

**853 MUX Between RF Ports 0, 1, 2, and 3**

Command #853 multiplexes between RF ports 0, 1, 2, and 3.

Reader response:

Done

**891 MUX Test Mode RF Port 1 Only**

Command #891 turns on RF port 1 only for antenna mux testing.

Reader response:

Done

*Note: See “MUX Test Modes” on page 7-38 for test operation.*

**892 MUX Test Mode RF Port 2 Only**

Command #892 turns on RF port 2 only for antenna mux testing.

Reader response:

Done

*Note: See “MUX Test Modes” on page 7-38 for test operation.*

**893 MUX Test Mode RF Port 3 Only**

Command #893 turns on RF port 3 only for antenna mux testing.

Reader response:

Done

*Note: See “MUX Test Modes” on page 7-38 for test operation.*

**Check Tag Operation**

**To enable check tag 0, issue the following commands**

#8110 – turn on RF port0, send the command on Ctag pin 0, to fire off Ctag address 0.

#8111 – turn on RF port1, send the command on Ctag pin 0, to fire off Ctag address 1.

#8142X – send the command on Ctag pin 0 to set the Ctag character.

#8150 – send the command on Ctag pin 0 to set the Ctag address to 0.

#8151 – send the command on Ctag pin 0 to set the Ctag address to 1.

**To enable check tag 1, issue the following commands**

#8112 – turn on RF port2, send the command on Ctag pin 1, to fire off Ctag address 0.

#8113 – turn on RF port3, send the command on Ctag pin 1, to fire off Ctag address 1.

#8143X – send the command on Ctag pin 1 to set the Ctag character.

#8152 – send the command on Ctag pin 1 to set the Ctag address to 0.

#8153 – send the command on Ctag pin 1 to set the Ctag address to 1.

---

## ***MUX Operational Modes***

**To enable antenna multiplexing (muxing) operational modes, issue the following commands**

#836/#837 – Disable/enable MPRR mode

#850 – RF port 0 only (factory default)

#851 – mux between RF ports 0 and 1

#852 – mux between RF ports 0, 1, and 2

#853 – mux between RF ports 0, 1, 2, and 3

#552 – Display mux setting. This display message will include “MPRR” if MPRR mode is enabled (#837).

When MPRR mode is disabled, the reader will continuously step through each port that has been enabled with #85X, stepping through whichever tag protocols are enabled on each port, in order. The reader turning RF on will be qualified “RF on by sense” setting. Command #6401 is used to turn RF on continuously and bypass the RF on by sense. Sense0 is used for all antennas that are enabled, if RF is turned on by sense, #641.

When MPRR mode is enabled, you must use Sense0 and Sense1 to turn on RF and read tags. Sense0, when shorted to reader signal ground, will enable tag reads on RF ports 0 and 1 (if enabled with #851) and Sense1 will enable tag reads on Ports 2 and 3 (if enabled with #853). For example, if commands #837 and #853 have been entered, Sense0 is open, Sense1 shorted, and the reader is in data mode, the reader will attempt tag reads toggling between RF ports 2 and 3 only. Smart muxing, ATA tag data sniffing, and ATA dwell of two handshakes per antenna is automatic in MPRR mode.

---

## ***MUX Test Modes***

**To enable antenna muxing test modes, issue the following commands**

#891 – RF port 1 only

#892 – RF port 2 only

#893 – RF port 3 only

To use these test modes, MPRR mode must be disabled (#836) and muxing must be disabled (#850). These command modes are not saved to NVM, and will be cleared by a power cycle of the reader, or by enabling either MPRR mode or muxing. When these

modes are enabled, the reader will continually run through whichever tag protocols have been enabled, but only on the selected RF port. These test mode commands are qualified by the RF on by sense settings. Use #6401 to disable RF on by sense, if desired.



---

# Configuring the Multiprotocol Rail Reader



---

# Configuring the Multiprotocol Rail Reader

*This chapter provides instructions for configuring the Multiprotocol Rail Reader (MPRR). The information includes factory configuration parameter defaults and instructions for using terminal emulation software to verify and change the MPRR factory configuration defaults.*

---

## Configuring the Reader

After installing the MPRR, you need to configure its operating parameters. Terminal settings should be initially set at 9600 baud, 8 data bits, no parity, 1 stop bit, and no flow control.

---

### Default Operating Parameter Settings

Table 8-1 contains the factory default configuration settings for the MPRR operating parameters. The default configuration settings may not be the correct operating configuration settings for a specific site. Changes to the configuration settings may have to be made, depending on the site plan, as described in Chapter 2 “Developing the Site Plan”

Review the default configurations shown in Table 8-1 to determine which parameters, in addition to operating frequency and operating range, need to be adjusted. Refer to Chapter 7, “Commands”, for a complete list of parameters and the corresponding commands.

*Note: The dual-protocol MPRR internal timing varies depending on the operative tag read mode and the type of tag in the read field.*

**Table 8-1 MPRR Default Configuration Settings**

Parameter	Setting	Command
Operating mode	Data	00
Baud rate	9600	1005
Stop bits	1	1010
Parity	None	1020
Time and date appended	Enabled	302
Auxiliary information appended	Disabled	310
Unique ID code criteria	Separation of 1 ID	4100
Tag translation mode	Disabled	452

**Table 8-1 MPRR Default Configuration Settings (continued)**

<b>Parameter</b>	<b>Setting</b>	<b>Command</b>
SeGo protocol tag initialization during multi-tag sort	Enabled	456
Reader ID number	00	6000
Communications protocol	Basic	610
Error correcting protocol (ECP) timeout	12.7 sec	612FE
Flow control	Software (XON/XOFF)	6141
Echo mode	Enabled	6171
ATA operating range	Maximum	6431F
RF attenuation	Full power	64400
SeGo protocol tag operating range	Maximum	6451F
Presence without tag reports	Disabled	6900
RF-off control	Timeout or no presence	6922
RF timeout	Never true	693F
Input inversion	Disabled	6940
Serial number	SSSSSS	695
Store hardware configuration	Hardware configuration not known	696
Automatic periodic RF status report	Disabled	830

## ***Configuring Parameters with Terminal Emulation Software***

To configure the MPRR using a PC and terminal emulation software to manually enter MPRR host commands, follow the instructions in the section [“Connecting the MPRR to the Host”](#) on page 4-13. Then, enter the appropriate configuration commands through the terminal emulation software on the host.

See [Chapter 7, “Commands,”](#) for a detailed description of all available configuration commands.

### ***Starting the Terminal Emulation Software***

You can use a PC and any terminal emulation software to enter the host commands to download flash software, configure reader operating parameters, perform diagnostics, and retrieve tag data. The following procedures show examples using Hyper Terminal, an application included with Microsoft Windows. Most terminal emulation applications have a similar sequence for launching.



**To start the terminal emulation software**

1. At the command prompt, type your terminal emulation start command; or if using Windows Hyper Terminal, select:  
Programs>Accessories>Hyperterm  
and press **ENTER**.

The application displays the Connection Description dialog box as shown in .



**Figure 8-1 Connection Description Dialog Box**

2. Enter a name for the session and click **OK**.

The application displays the **Phone Number** dialog box as shown in [Figure 8-2](#).

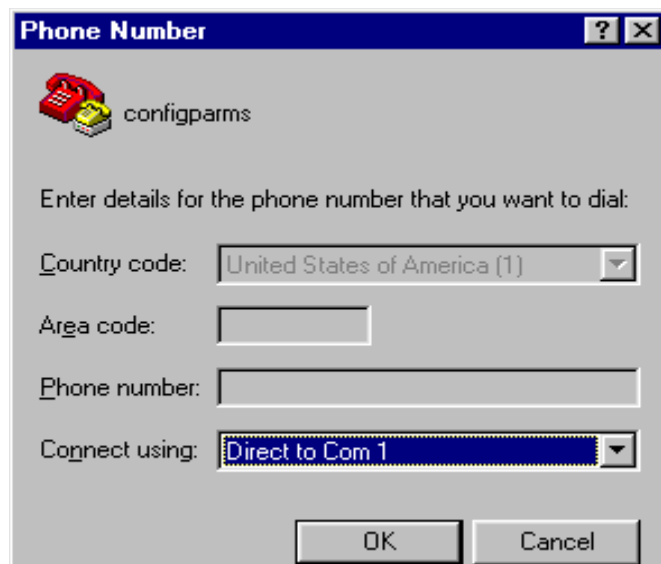

**Figure 8-2 Phone Number Dialog Box**

3. From the **Connect using** pull-down list, choose the **Com 1** option (or whichever com port on the PC to which the RS-232 cable is attached) and click **OK**.

The application displays the **COM1 Properties** dialog box as shown in [Figure 8-3](#).

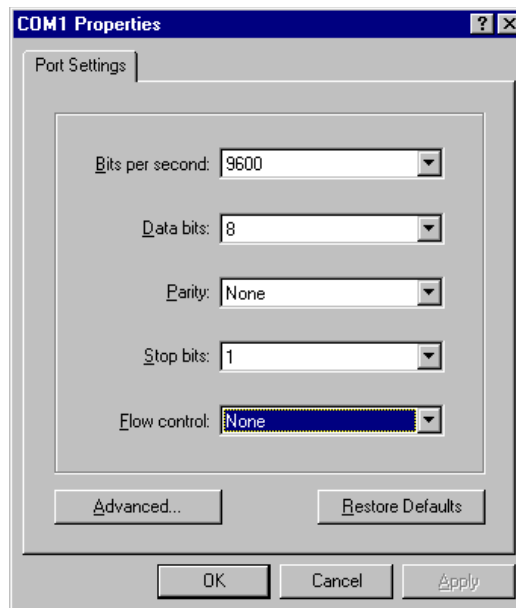
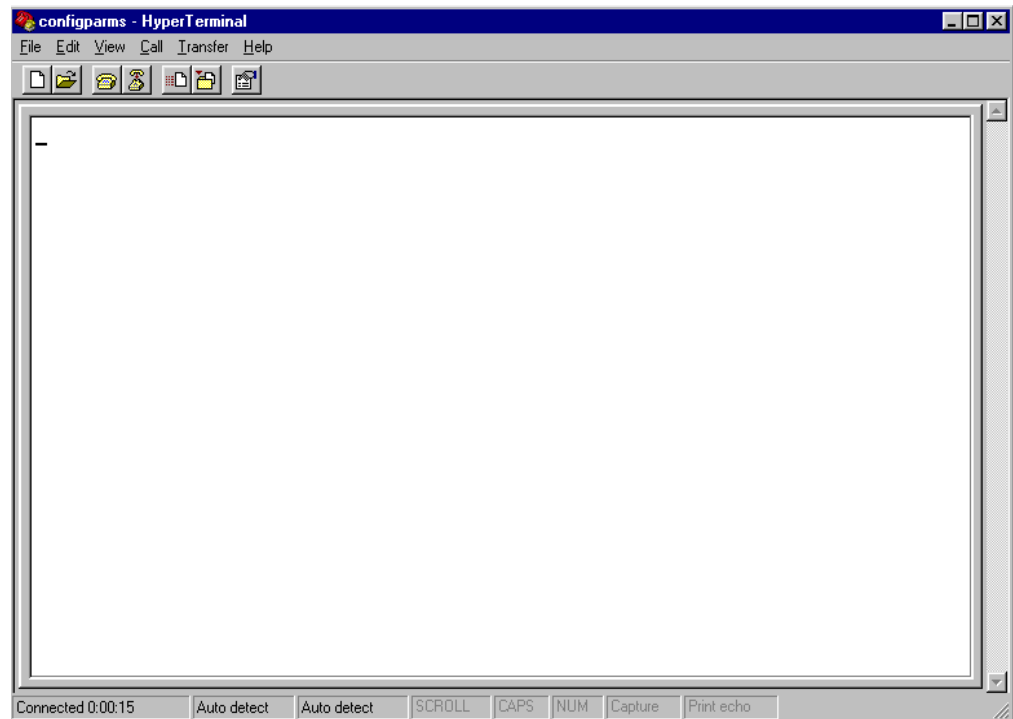

**Figure 8-3 COM 1 Properties Dialog Box**

4. In the pull-down lists on the **COM1 Properties** dialog box, choose the following values:
  - Bits per second: 9600 baud
  - Data bits: 8
  - Parity: None
  - Stop bits: 1
  - Flow control: None

Click **OK**.

The application displays the **configparms - Hyper Terminal** main screen as shown in [Figure 8-4](#).



**Figure 8-4 Hyper Terminal Main Screen**

---

## Verifying Communications

You must verify that the MPRR and the PC or laptop are communicating.

### To verify communications

1. Start the terminal emulation application as described previously in [“Starting the Terminal Emulation Software”](#) on page 8-4.

*Note:* When testing the MPRR using a laptop computer, TransCore recommends that you configure laptop communication parameters to match those of the host device to which the MPRR will be connected after testing and configuration are completed.

2. Cycle the power on the MPRR.

Upon startup, the MPRR transmits a sign-on message, displayed on the terminal emulation screen as shown in [Figure 8-5](#), or a boot ROM failure message.

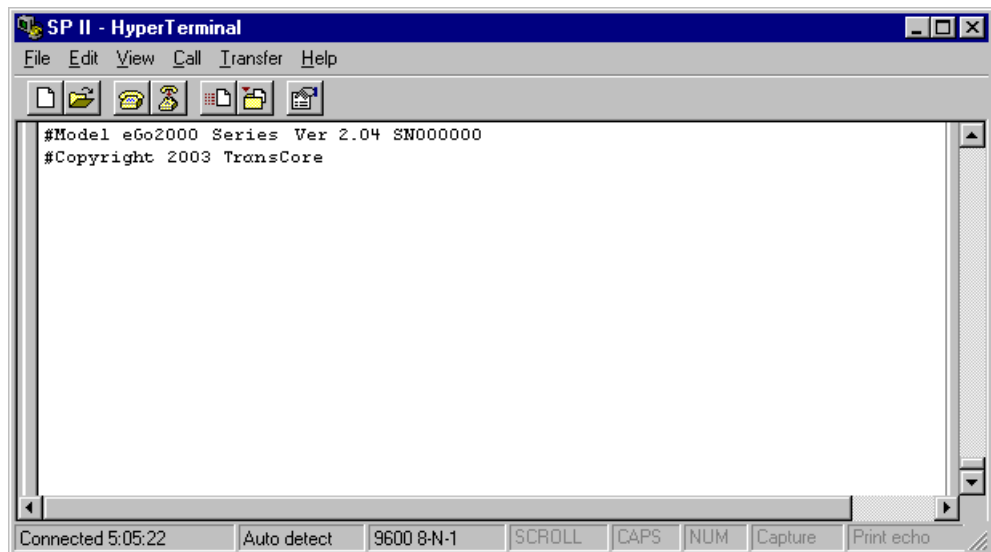

**Figure 8-5 Sign-on Message**

The sign-on message appears as follows at a baud rate of 38,400 bps:

```
Model [software version] SNSSSSSS  
[Copyright notice]
```

where SSSSSS is the serial number assigned to the MPRR skipping the fourth character printed on the reader product label.

Serial number 000000 is the default setting and is not a valid number. If this number appears in the sign-on message, the serial number has not been stored into reader memory. Contact TransCore Technical Support at 214-461-6449.

If the flash memory checksum is not verifiable, the sign-on message appears as follows:

```
Model [E4 BOOT] Ver 0.00 A  
[Copyright notice]
```

If the failure message version number equals 0.00 E and no serial number exists, the flash memory checksum has failed, and the MPRR is operating out of boot ROM. In this case, the MPRR automatically enters download mode and waits for a new program to be loaded into the flash memory. Follow the instructions in [“Program Download” on page 5-5](#).

Communications can also be verified by using the command sequence in [Table 8-2](#).

**Table 8-2 Command Sequence to Verify Communications**

Entry	MPRR Response	Notes
#01 <CR>	#Done <CR/LF>	Switches the MPRR to command mode
#505 <CR>	#Model E4 Series Ver X.XX SN97001P <CR/LF>	Reports the software version and serial number
#00 <CR>	#Done <CR/LF>	Returns the MPRR to data mode

3. If a successful sign-on message is not returned, check connections and communications factors and correct any errors.

**To check connections and communications factors**

1. Confirm that the MPRR has power.
2. Verify the connections between the PC and the MPRR.
3. Verify the receive (Rx) and transmit (Tx) connections.
4. If using handshaking, verify the request to send (RTS) and clear to send (CTS) connections.
5. Verify the COM port settings for the MPRR using the instructions in [“Serial Port Communications” on page 8-16](#).

Repeat the procedures in [“Verifying Communications” on page 8-7](#).

If you still cannot verify the MPRR and PC communications, use the information in [“Technical Support” on page 9-6](#) to contact TransCore.

---

## Verifying Tag Read Capability

After verifying communications between the MPRR and the PC, verify the capability to read tags. The test tag should match the tag type and protocol of the tags that your system will be reading.

The polarization of the test tag must be aligned in the same direction as the antenna. [Figure 8-6](#) shows horizontally polarized antenna and tag.

**Note:** *Matching the tag and antenna polarization is critical to obtain optimal system performance.*

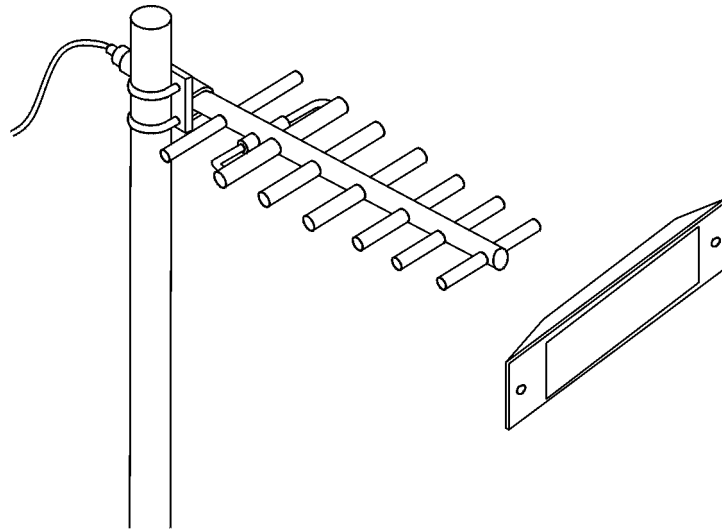

TA-0016

**Figure 8-6 Tag and Antenna Orientation (horizontal polarization)**

The test tag must be mounted flush against a metal backplane.

*Note:* The default tag read mode of the reader is the protocol(s) programmed into the reader. Use only those test tags programmed with the correct protocol(s) for the reader.



**Caution**

*To avoid damage to the MPRR using an external antenna, you must connect the antenna before applying power to the reader.*

**To verify tag read capability**

1. Once communications are verified as described in [“Verifying Communications” on page 8-7](#), enter the following sequence of commands to turn on continuous RF:
  - #01
  - #6401
  - #40
  - #00
2. Pass one test tag in front of the active MPRR antenna. If the MPRR reads the tag, the terminal emulation application displays the tag information on the screen as shown in [Figure 8-7](#).

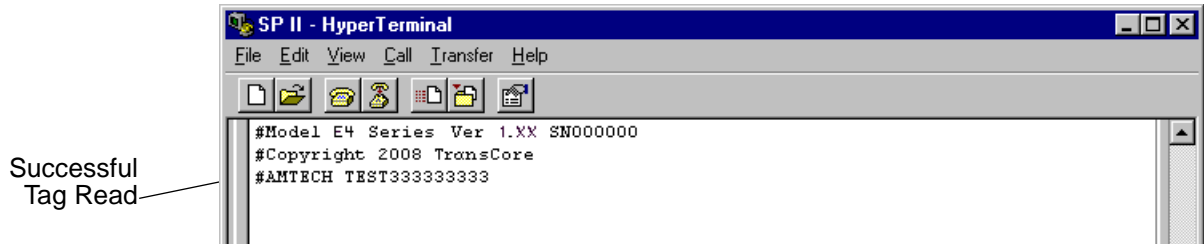

**Figure 8-7 Successful Tag Read**

If the tag ID is not displayed, perform the following actions:

- Verify that the MPRR is in data mode (command #00 Switch to Data Mode).
  - Ensure that the tag you are using is compatible with the MPRR. The MPRR can read tag types that are compatible with the reader model.
  - An MPRR displays the tag read for any tag that is compatible with the reader programming.
  - Using the audible circuit tester as described in “[Testing the MPRR Using an Audible Circuit Tester](#)” on page 4-4, verify that the reader is capable of reading the tag in the read zone. If it is, the problem is probably in the communications between the MPRR and the host.
3. Pass a different reader-compatible test tag in front of the MPRR antenna.
  4. When the MPRR reads the second tag successfully, the terminal emulation application displays that tag’s information in the main screen below the information for the first tag, as shown in [Figure 8-8](#).

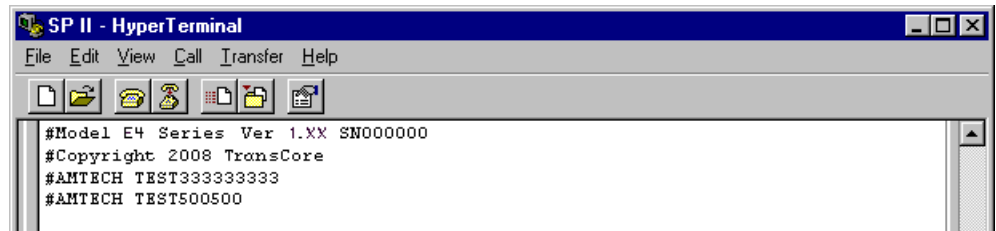

**Figure 8-8 Second Successful Tag Read**

If the read is unsuccessful, perform the following actions:

- Ensure the tag you are using is compatible with the MPRR.

- Using the audible circuit tester as described in [“Testing the MPRR Using an Audible Circuit Tester”](#) on page 4-4, verify that the reader is capable of reading the tag in the read zone. If it is, the problem is probably in the communications between the MPRR and the host device.

## **Configuring MPRR Parameters**

---

Follow the procedures in this section to configure MPRR parameters using a PC, laptop, or terminal emulator. The PC or laptop must be connected to and communicating with the MPRR, and the terminal emulation application must be configured correctly, as described in the section [“Verifying Communications”](#) on page 8-7.

### **To configure parameters**

1. Switch to command mode by typing **#01** at the prompt on the terminal emulation screen, and pressing **ENTER**.

*Note: All MPRR commands are preceded by the start-of-message character (#).*

2. To meet requirements of your site, make changes to default operating parameters as described in the following sections.

The following sections contain procedures to set some of the parameters that are commonly changed to meet the requirements of a specific site. Procedures are listed in alphabetical order by parameter.

---

## **Appended Tag Data**

Use this procedure to set appended tag data parameters using the terminal emulation application. See [“31N Append Auxiliary Information Selection”](#) on page 7-10 for more information.

### **To set appended tag data parameters**

1. Ensure that the host device is in command mode.
2. Enter command **#311** to append auxiliary information or command **#310** to have no auxiliary information appended (factory default). Press **ENTER**.

---

## **ID Separation**

The host can select a unique ID separation of one ID or two IDs. The reader default operation is for a unique ID separation of one ID and a uniqueness timeout of two minutes. You can disable the uniqueness check using command **#40** Transmit All ID Codes. In this case, every tag ID received is transmitted without regard to uniqueness. You can reinstate uniqueness checking with commands **#4100** or **#4101** Select ID Separation.

*Note: The MPRR internal timing varies depending on the operative tag read mode and the type of tag in the read field.*



See section “40 Transmit All ID Codes” on page 7-11 and section “410N Select Unique ID Code Criteria (Anti-passback Feature)” on page 7-12.

### To set ID separation parameters

1. Ensure that the host device is in command mode.
2. Enter command **#4100** to select a separation of one ID; enter command **#4101** to select a separation of two IDs. Press **ENTER**.

---

## Reports

The MPRR can be configured to transmit presence without tag reports and input status change reports. A presence without tag report is transmitted in data mode only, *and only if the system has a presence detector*. This report is sent if a presence is detected without the detection of a valid tag ID. See sections “529 Display Presence Input Status” on page 7-19 and “690N Select Presence Without Tag Report Option” on page 7-30.

### To set presence reporting

1. Ensure that the host device is in command mode.
2. Enter command **#529** to display presence input status and press **ENTER**. P0 indicates presence without tag reports disabled (factory default), and P1 indicates presence without tag reports enabled.
3. Enter command **#6901** to enable presence without tag reports, or enter command **#6900** to disable presence without tag reports (factory default). Press **ENTER**.

### To set input status change reporting

1. Ensure that the host device is in command mode.
2. Enter command **#560** to display input status change report options and press **ENTER**.
  - E0 = input status change reports disabled (factory default)
  - E1 = input status change reports enabled
  - M0 = reporting disabled (factory default)
  - M1 = changes on input0 reported
  - M2 = changes on input1 reported
  - M3 = changes on either input reported

---

## Reset Reader

Command #63 Reset Reader resets uniqueness, clears the power fail bit, and transmits the sign-on message. The reader returns to data mode following the completion of this command.

*Note:* This command does **not** reset any of the configuration parameters.

See “63 Reset Reader” on page 7-26.

### To reset the reader

1. Ensure that the host device is in command mode.
2. Enter command **#63**. Press **ENTER**.

The terminal emulation screen displays the sign-on message as shown in [Figure 8-5 on page 8-8](#).

---

## Radio Frequency



### Caution

*The authorized continuous wave (CW) frequency band for the MPRR in the U.S. is 902.25 to 903.75 MHz and 910.00 to 921.50 MHz and the authorized modulated frequency band for the MPRR in the U.S. is 911.75 to 919.75 MHz. The RF for each MPRR at the site must be set according to the frequency specified in the FCC site license. Only trained, authorized installation and maintenance personnel are permitted by FCC to set the RF.*

By using the MPRR an authorized person can set the frequency within the range from 902 to 928 MHz in 0.25 MHz steps. You can set the frequency by using a terminal emulation program and issuing the frequency command, as discussed in section [“647XXX Select RF Operating Frequency” on page 7-29](#).

*Note: For backward compatibility to existing controllers, you can set the RF operating frequency in 500-kHz steps using command **#642NN**.*

### To set the frequency range

1. Ensure that the host device is in command mode.
2. Enter command **#647XXX** – where **XXX** is a hexadecimal value from 000 to 118 – and press **ENTER**. See command [“647XXX Select RF Operating Frequency” on page 7-29](#) for a complete listing of the hexadecimal values and the corresponding frequencies.
3. To verify that the RF has been changed to the proper setting, type in command **#527** to see the current frequency setting.



### Caution

*Contact TransCore if your application requires a frequency outside of the authorized frequency range.*

---

## RF Transmission

The RF transmission can be controlled by one of the following methods:

- Connecting a presence detector to the SENSE0 circuit
- The host device sending software commands to the MPRR

As a factory default, the MPRR is configured to control the RF power with a presence detector. [Figure 8-9](#) illustrates the methods of controlling RF sense output.

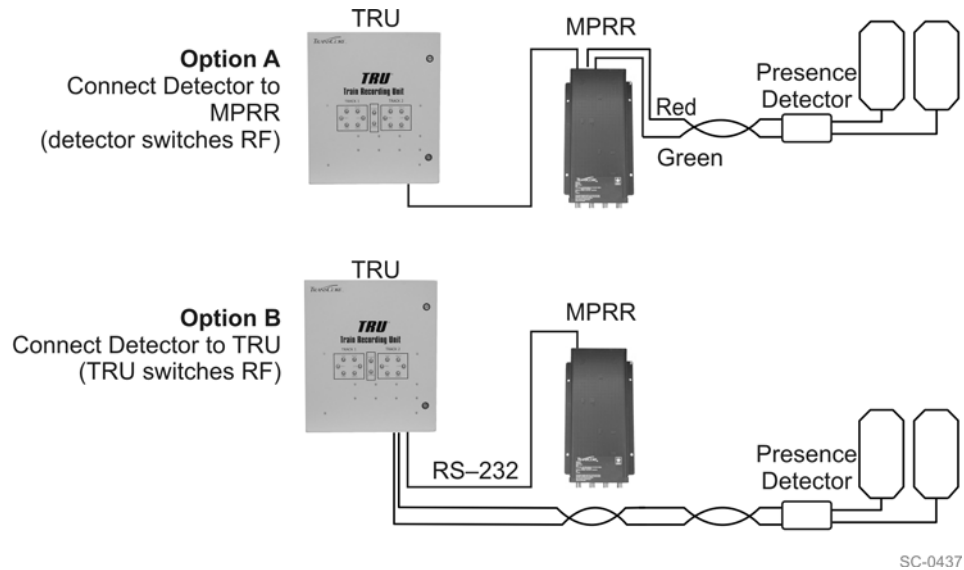

Figure 8-9 MPRR RF Control Options

### Presence Detector Controlling RF Transmission

The presence detector can be a loop detector, a track circuit, an infrared sensor, an ultrasonic sensor, or another presence detection device that is connected to sense input0 to turn on the MPRR RF transmitter. In Figure 8-9, Option A shows a presence detector controlling the RF transmitter. This operation ensures that the RF is “on” only when a train is in the MPRR read zone. Command #641 Select RF-by-Input Control (factory default) must be enabled.

To set the option of the presence detector controlling the MPRR

Ensure that the host device is in command mode.

Enter command #641. Press **ENTER**.

Leave the setting on RF-by-input control for normal operation.

### Host Controlling RF Transmission

In Figure 8-9, Option B shows the host controlling the RF transmitter. This is the most common implementation.

If the presence detector is connected to the host device, as shown in Option B, commands #6400 RF Off and #6401 RF On sent from the host device turn on and off the MPRR RF transmitter.

---

## Sense Inputs

The RS-232 configuration used by the MPRR has two sense inputs — SENSE0 and SENSE1. SENSE0 is used to enable RF on antenna ports 0 and 1 if enabled, and

SENSE1 is used to enable RF on antenna ports 2 and 3. The sense input circuits are used to notify the MPRR of train presence and are designed to be connected to a free-of-voltage dry contact. The MPRR sense inputs are designed to connect to a dry contact closure.

You can configure the MPRR to generate input status change reports, which are transmitted like tag IDs. The host can then respond based on the true/false (closed/open) status of the sense inputs. See the section [“Reports” on page 8-13](#).

The following procedures describe how to set sense inputs using the terminal emulation software. See command [“694N Select Input Inversion Option” on page 7-32](#) for more information.

#### **To set sense inputs**

1. Ensure that the host device is in command mode.
2. Enter command **#6940** to disable input inversion (factory default) or command **#6941** to enable input inversion, and press **ENTER**.

---

## ***Sense Output Device***

The sense output is dedicated for testing and set up of the reader. It is defined as the TAG\_LOCK signal and indicates that a valid tag is in the read field.

This sense output is a dry contact that provides a normally open and normally closed sense output. The relay contacts are rated at 42.2V AC peak (30 V<sub>rms</sub>) or 60V DC at 1 A maximum. If controlling an external gate or device requiring high current, an isolation transformer is required.

---

## ***Serial Port Communications***

The MPRR supports one RS-232 communications port. For the RS-232 communications specification, the MPRR maintains the following three sets of parameters that affect serial port communications:

- Port configuration parameters (baud rate, data bits, stop bits, parity)
- Communications protocols (basic, error correcting)
- Flow control scheme (none, software, hardware)

The default serial port configuration for each of these three parameters is as follows:

- 9600 baud, 8 data bits, 1 stop bit, no parity
- Basic communications protocol
- Software flow control (XON/XOFF)

You can change these parameters in data mode and command mode operation by issuing commands with the host device. Use the following procedures to set serial port communications parameters using the terminal emulation program.

---

## Port Configuration Parameters

Use this procedure to set port configuration parameters using the terminal emulation program. Consult sections “[100N Select Baud Rate](#)” through “[102N Select Parity](#)” on [page 7-8](#).

### To set baud rate

1. Ensure that the host device is in command mode.
2. Enter command **#100N** and press **ENTER**.

### To set stop bits

1. Ensure that the host device is in command mode.
2. Enter command **#101N** and press **ENTER**.

### To set parity

1. Ensure that the host device is in command mode.
2. Enter command **#102N** and press **ENTER**.

---

## Communications Protocol

Use the following procedures to set communications protocol. Consult sections “[610 Select Basic Communication Protocol \(Factory Default\)](#)” through “[612NN Select Error Correcting Protocol Timeout](#)” on [page 7-25](#) for more information.



### Caution

*Do not switch to ECP (command #611) unless the host is prepared to acknowledge each reader transmission.*

### To select a communications protocol

1. Ensure that the host device is in command mode.
2. Enter command **#610** to select basic protocol (factory default) or command **#611** to select ECP and press **ENTER**.

---

## Software Flow Control

Two modes of flow control are supported — software (XON/XOFF) and hardware (CTS - clear to send). The host can enable or disable flow control with command **#614N** Select Flow Control Option.

The host can use software control characters (XON/XOFF) or the hardware CTS handshake line to interrupt reader transmissions. When the reader is configured for software flow control, it stops transmitting if it receives the XOFF character from the host (host software command 13H). It resumes transmitting only when it receives the XON character (host software command 11H) from the host. Likewise, when the reader is configured for hardware flow control, it stops transmitting if it detects that the CTS line is no longer asserted. It resumes transmitting when this line is asserted. If flow control is not needed, the reader should be configured for no flow control (**#6140** Disable Flow Control).

*Note: TransCore recommends that XON/XOFF flow control be disabled while using the ECP.*

Use the following procedure to set flow control parameters using the terminal emulation program. See section [“614N Select Flow Control Option”](#) on page 7-25.

**To select flow control**

1. Ensure that the host device is in command mode.
2. Enter command **#6140** to disable flow control, command **#6141** to enable software flow control (factory default), or command **#6142** to enable hardware flow control and press **ENTER**.

---

## ***Fine-Tuning and Verifying the Read Zone***

If the read zone is too wide or too deep for your application, it can be fine-tuned by physically adjusting the MPRR or external antenna mounting orientation, reprogramming the actual RF power output (#644NN Set RF Attenuation), and/or reprogramming the RF sensitivity range (#643NN Set ATA Operating Range (Distance) and #645NN Set SeGo Protocol Tag Operating Range). The combination of these adjustments allows you to confine the read zone to the area where tagged vehicles pass.

See sections [“643NN Select ATA Operating Range \(Distance\)”](#) on page 7-27, [“645NN Set SeGo Protocol Operating Range \(Distance\)”](#) on page 7-28, and [“644NN Set RF Attenuation”](#) on page 7-28 for more information.

*Note: As described in “Marking the Read Zone” on page 4-14, marking the read pattern using test tags that are hand-carried by a tester gives a general idea of the read pattern but the pattern may vary somewhat when actual rail assets are read.*

### ***Physically Orienting the MPRR Antenna(s)***

You can manually adjust the location of the read zone by loosening the antenna(s) mounting hardware and pointing the antenna in the desired direction. The unit should be aligned to point directly at the tag as it enters the desired read zone.

### ***Fine-Tuning the Read Zone by Lowering Output Power***

You can make the read zone smaller by adjusting the MPRR RF power output from a maximum of 2 watts to a minimum of 200 milliwatts using command #644NN Set RF Attenuation.

#### **To adjust the read zone by lowering output power**

1. Ensure that your PC is communicating with the MPRR using a terminal emulation program as described in section [“Verifying Communications”](#) on page 8-7.
2. Mark the current read zone as described in section [“Marking the Read Zone”](#) on page 4-14.



**Caution**

*Test tags should be compatible with your MPRR. Test tags can be AAR-formatted or SeGo-protocol tags.*

3. Enter command **#01** to switch to command mode. You are prompted with **#DONE** from the reader and can now enter reader commands.
4. Enter in command **#64401** to lower the RF power by 1 dB below 2 watts (default). Press **ENTER**.

*Note:* In the command **#644NN**, **NN** can be any hexadecimal value from **00** to **0A**. Settings for attenuation are **1.0 dB** increments over a range of **10 dB** of attenuation from the maximum power setting of **2 watts** at **0 dB** attenuation to a minimum power level of **200 milliwatts** at **10 dB** attenuation. Increasing the attenuation lowers the output RF power.

5. Switch to data mode by entering command **#00** and pressing **ENTER**.
6. Verify that the read zone has decreased by moving the tag through the desired read area. If the read zone is still too large, switch to command mode and enter the command **#64402** to lower the output RF power another 1 dB. Continue increasing the **NN** value until the read zone matches the desired read zone.

When the desired read zone is established, test the read zone with simulated and real traffic by performing the following procedures:

### To test the read zone

1. Ensure that the MPRR is in data mode.
2. With the MPRR running, place one tag behind your back while you hold another tag in the new read zone. If a valid read, the data from the tag held in the read zone displays on the PC screen.
3. Switch tags, placing the other tag behind your back and holding the first tag in the read zone. If a valid read, the data from this tag held in the read zone displays on the PC screen. If both tags are read, you have successfully adjusted the read range.
4. If one or both tags did not read, follow the suggestions in [“Verifying Tag Read Capability”](#) on page 8-9.

### Fine-tuning the Read Zone by Adjusting Sensitivity Range

The MPRR read zone can be fine-tuned by using command **#643NN** for ATA protocol tag read mode or **#645NN** for SeGo protocol tag read mode to reprogram the RF sensitivity range. Sensitivity range adjustments have less impact on the read pattern than RF power adjustment, thus RF power adjustment should be used as the main read pattern adjustment tool. Sensitivity range control may be helpful in stopping some tag reads on the very edges of the read pattern. To produce a noticeable change in the read pattern, you must decrease the range sensitivity by more than one increment.

### To adjust the read zone by adjusting sensitivity range

1. Ensure that your PC is communicating with the MPRR using a terminal emulation program as described in [“Verifying Communications”](#) on page 8-7.
2. Mark the current read zone as described in [“Marking the Read Zone”](#) on page 4-14.

3. Enter command **#01** to switch to command mode. You are prompted with **#DONE** from the reader and can now enter reader commands.
4. Enter command **#64318** or **#64518** to decrease the range sensitivity seven increments below the maximum (default). Press **ENTER**.

*Note: In the command #643NN or #645NN, NN can be any hexadecimal value from 00 to 1F. The reader's receiver becomes less sensitive to tag signals as the value of NN is lowered from the maximum sensitivity of 1F to the minimum sensitivity of 00.*

5. Verify that the read zone has decreased by moving the tag through the desired read area. If the read zone is still too large, switch to command mode and enter the command **#64317** or **#64517** to decrease the range another increment. Continue increasing the NN value until the read zone matches the desired read zone.

When the desired read zone is established, test the read zone with simulated and real traffic by performing the following procedures.

### To test the read zone

1. Ensure that the MPRR is in data mode.
2. With the MPRR operating, place one tag behind your back while you hold another tag in the new read zone. If a valid read, the data from the tag held in the read zone displays on the host device screen.
3. Switch tags, placing the other tag behind your back and holding the first tag in the read zone. If a valid read, the data from this tag held in the read zone displays on the host device screen.
4. If both tags are read, you have successfully adjusted the read range. If one or both tags did not read, follow the suggestions in [“Verifying Tag Read Capability” on page 8-9](#).



---

## Troubleshooting and Maintenance



## Troubleshooting and Maintenance

*This chapter contains information for troubleshooting a Multiprotocol Rail Reader (MPRR) and performing minimal maintenance checks. The chapter also includes information for returning products for repair, technical support, and contact information for providing feedback and suggestions to TransCore.*

### Error Messages

The MPRR transmits an error message if a command received from the host is not a recognized command or if information supplied with the command is incorrect. The reader sends this message to diagnostic commands if the reader fails the specified test.

Table 9-1 contains a list of error messages.

**Table 9-1 Error Messages**

Error Message	Description	Corrective Action
Error06	NVRAM parameters have been lost. The MPRR will not function properly because the RF section is shut off until the frequency is reset.	Reset the frequency using command #647XXX.
Error07	The RF phase locked loop (PLL) has lost lock and is unable to operate at its intended frequency. RF output is disabled while the MPRR attempts to reset the PLL.	Reset the RF frequency. Refer to “Radio Frequency” on page 8-14 for instructions.
Error08	The RF PLL has successfully regained lock and has been reset to its proper operating frequency. The RF section is returned to its state prior to losing lock (enabled/disabled). <i>Error08</i> will only be issued after <i>Error07</i> has been issued.	No action necessary; the previous error has been corrected.
ErrorRF1	Warning message that the RF board did not return an update acknowledge signal	If the reader indicates a single ErrorRF1 event and recovers from the error, no corrective action is required. You may want to track this error message if it should occur again. If the reader indicates repeated ErrorRF1 warning messages then return the reader to the factory.

Table 9-1 Error Messages (continued)

Error Message	Description	Corrective Action
ErrorRF2	Warning message that the RF module did not return an INIT DONE signal	If the reader indicates a single ErrorRF2 event and recovers from the error, no corrective action is required. You may want to track this error message if it should occur again. If the reader indicates repeated ErrorRF2 warning messages then return the reader to the factory.
ErrorRF3	Warning message of unexpected status read, including status byte, from RF module	If the reader indicates a single ErrorRF3 event and recovers from the error, no corrective action is required. You may want to track this error message if it should occur again. If the reader indicates repeated ErrorRF3 warning messages then return the reader to the factory.

## Troubleshooting

You can use the following table for troubleshooting. Should problems continue, contact TransCore for return and replacement procedures. If you contact Technical Support, use the symptom number in [Table 9-2](#) to reference the problem that you are having with the MPRR.

Table 9-2 Symptoms and Remedies

Symptom Number <sup>a</sup>	Symptom	Remedy
1	When performing a quick test of the MPRR, the buzz box does not buzz.	<p>Check all your wiring connections and antenna connections (if using external antenna), and ensure that your buzz box is functioning.</p> <p>The wires from the MPRR are grouped in pairs. You could find more than one red wire, more than one black wire, and so on. You must connect the correct red and white wire pair to the leads from the battery.</p> <p>Verify that RF is on. Using a terminal emulation program, you may switch to command mode and issue command #527 to determine RF status. See page 7-18 for more information.</p>
2	The baud rate is selected correctly but nothing happens.	The MPRR is not communicating with your host device. Check the power supply to your host device, and check the connections between the host device and the MPRR. Try reversing the receive and transmit connections.

Table 9-2 Symptoms and Remedies (continued)

Symptom Number <sup>a</sup>	Symptom	Remedy
3	When testing the MPRR, all the wires are connected correctly but the unit does not respond.	<p>The MPRR may not have the software loaded inside the unit. Contact Technical Support as described on page 9-6.</p> <p>If you are using a terminal emulation program, check that the terminal emulation setting on the MPRR is VT100.</p> <p>Check that the MPRR communication cable is connected to the correct COM port.</p> <p>Verify that the external antenna is connected correctly.</p>
4	Strange signal responses come from the MPRR when tested with the PC.	<p>Ensure that the reader is in the correct interface mode for the test tag, that is, AAR for an AAR-formatted tag.</p> <p>Check the system defaults using a terminal emulation program. Both PC and reader should be set to 9600 baud, 8 bits, 1 stop bit, and no parity.</p>
5	Nothing happens when the test tag is passed in front of the MPRR RF antenna.	<p>Ensure that the MPRR is powered on</p> <p>Verify that the reader is set to RF ON (#6401).</p> <p>Verify that the antenna is connected correctly.</p>
6	The MPRR came from another site and does not work the way the factory defaults indicate that it should.	<p>Different commands were probably used to support the other site's specific configuration. You can restore the factory defaults by using a terminal emulation program to switch to command mode and issuing command #66F Load Default Operating Parameters. All factory defaults except RF frequency will be restored.</p>
7	When connected to a PC that is running terminal communications software, a just-powered up MPRR displays one of the following messages: #Model E4 Series X.XX SNSSSSSS #[Copyright notice]	<p>The MPRR works. The software is now loaded. SSSSSS is the TransCore-assigned serial number for this MPRR. However, if SSSSSS = 000000, a serial number has never been assigned. If a serial number has not been assigned to your MPRR, contact TransCore Technical Support.</p>
8	The read zone is too small, even before the RF power and range control have been adjusted.	<p>If another MPRR is in the same area, ensure that it is operating on another frequency that is at least 2 MHz different.</p> <p>Check for possible interference from another nearby RF source: fluorescent lights, neon signs, high voltage power lines, nearby cellular telephone, or radio stations. Lights will need to be removed or shielded. Point the MPRR or external antenna in a different direction to see if interference comes from only one direction. You may require a different MPRR that uses another frequency.</p> <p>Verify that the RF power is set to an appropriate value.</p> <p>Verify that the range adjustment is set to the maximum.</p> <p>Verify that the reader is getting at least 16V.</p>

Table 9-2 Symptoms and Remedies (continued)

Symptom Number <sup>a</sup>	Symptom	Remedy
9	The perimeter of the read zone has been defined, but there is a “hollow” spot in the center of the zone that does not read tags.	The angle of the MPRR or external antenna may need adjustment. Slightly tilt the MPRR or external antenna to a different angle to change either the length or width of the read zone.  Check the range control adjustment. See <a href="#">“Radio Frequency” on page 8-14.</a>
10	The MPRR is reading tags out of the desired read zone.	Some interference from other RF or electrical sources may be occurring. See <a href="#">“Reflection, Refraction, and Diffraction of RF Signals” on page 2-9.</a>  Verify that the read zone has been properly set up. See <a href="#">“Fine-Tuning and Verifying the Read Zone” on page 8-18.</a>

<sup>a</sup>Use this number to reference the problem you are having with the MPRR if you contact Transcore for Technical Support.

## MPRR Repair

---

The MPRR is designed for whole-unit replacement and is manufactured with surface-mounted components. It requires sophisticated testing and repair equipment. All testing and repairs are performed at TransCore’s factory. Please contact TransCore to obtain a Return Materials Authorization (RMA) for returning the reader.

## Technical Support

---

Authorized dealers and distributors are responsible for the direct support of all customers. Authorized dealers and distributors needing support can contact TransCore Technical Support at (214) 461-6449. Please be prepared to answer a series of questions that are designed to direct you to the best TransCore support resource available. These questions will relate to symptoms, configuration, model, and tags used.

*Note: End users and facility operators contacting Technical Support will be referred to the dealer responsible for the system sale.*

## Marketing Support

---

Dealers requiring marketing support may call TransCore Marketing at (214) 461-6443, 9:00 a.m. to 5:00 p.m. Central Standard Time, Monday through Friday.

# 10

---

## Interface to Train Recording Unit





# Interface to Train Recording Unit

*This chapter describes the communication/power interface between the Multiprotocol Rail Reader (MPRR) and the Train Recording Unit (TRU™).*

## ***TRU System Overview***

---

The TRU is a system composed of hardware and software that is used at mainline rail locations in North America. The TRU records detailed information about trains, uses the information to create “consists” for the trains, and then transmits consist reports to a host computer system. A train “clean consist” report is a train listing in standing order, where orientation of tagged equipment is provided, location of untagged equipment is provided, and car count is accurate. The TRU accommodates normal operating procedures such as changes in speed and reverse and incorporates intelligence to handle both single and multi-track locations.

The TRU System hardware includes the TRU “box,” RFID reader(s) or connection for the Multiprotocol Rail Reader (MPRR), antennas, wheel detectors, presence loops, external device interfaces, communications interfaces, and other optional peripherals (Figure 10-1). For detailed information concerning this hardware see the *Train Recording Unit System Guide* (D/N 600109) and for quick installation and operating instructions see the *Train Recording Unit User Interface Quick Reference Guide* (D/N 600042).



Figure 10-1 TRU Front Panel Showing Operational LEDs

## ***MPRR to TRU Connection***

The MPRR and TRU typically are installed in the same railside hut and are connected by a communication/power cable. [Figure 10-2](#) shows the TRU circular connector port for the MPRR interface cable.

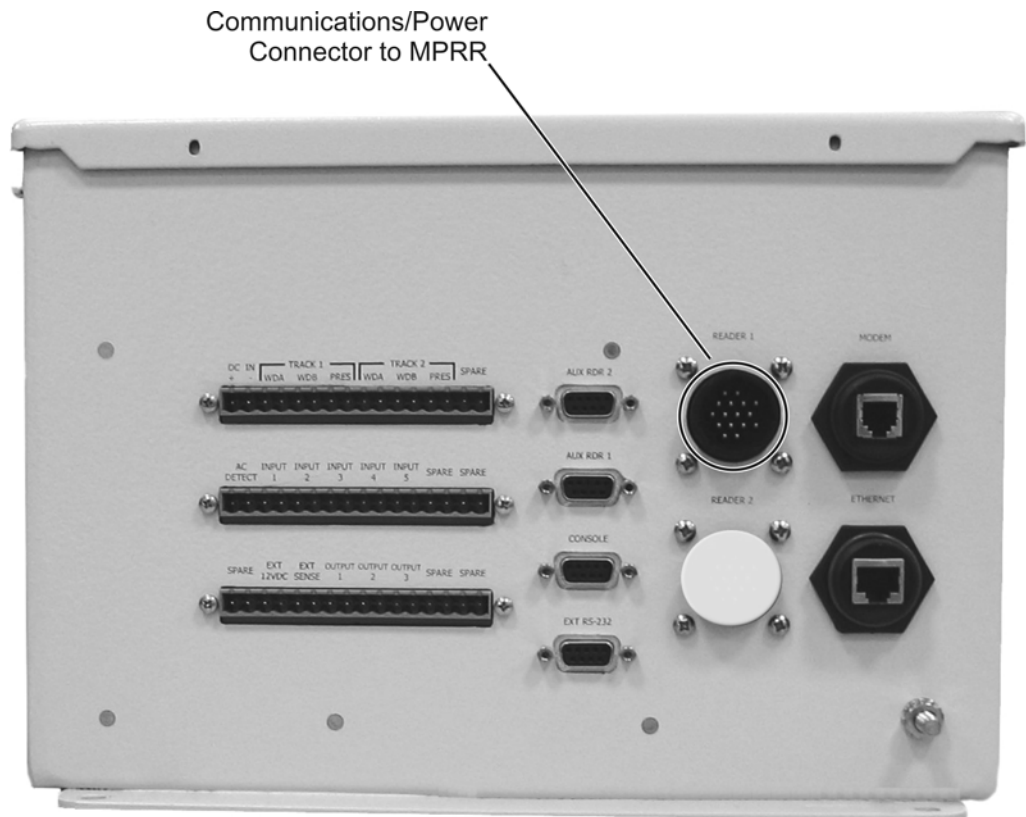

HW-0417

***Figure 10-2 TRU-MPRR Communications Interface Cable Port (bottom of TRU)***

Figure 10-3 shows a graphical representation of the communications interface cable.

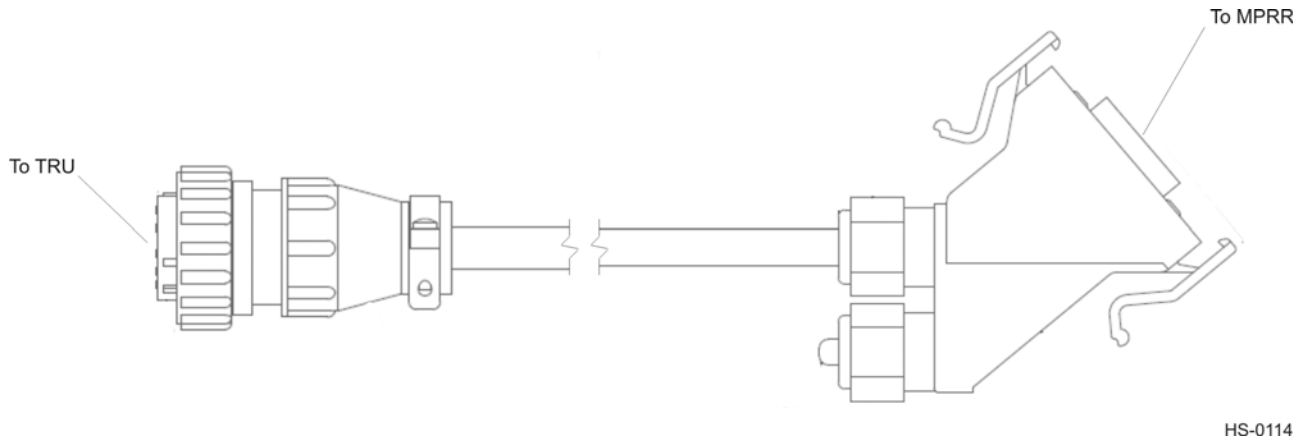

**Figure 10-3 MPRR-TRU Communications Interface Cable**

Table 10-1 lists the MPRR-to-TRU communications interface pin designations and signal descriptions.

**Table 10-1 MPRR-to-TRU Interface Cable Pin and Signal Designations**

MPRR Pin	Signal Designation	Signal Description	TRU Pin
1	TXD1	Transmit Data 1	8
2	GND	Signal Ground	15
3	LOCK	Lock	7
4	GND	Signal Ground	14
5	+24RTN	+24V Return	6
6	CTS1	Clear to Send 1	13
7	+24RTN	+24V Return	5
8	RTS1	Request to Send 1	12
9	+24V DC	Input Voltage	4
10	GND	Signal Ground	11
11	+24V DC	Input Voltage	3
12	LOCK_RTN	Lock Return	10
13	SENSE_1	Input Sense 1	2
14	RXD1	Receive Data 1	9
15	SENSE_0	Input Sense 0	1

---

AT5720 Check Tag-to-MPRR Assembly



# AT5270 Check Tag-to-MPRR Assembly

*This document describes the procedures to assemble and connect a check tag assembly to a Multiprotocol Rail Reader (MPRR).*

## Required Supplies

---

Before assembling the check tag antenna kit, make sure you have the necessary supplies and tools for this task. Check Tag Kit (TransCore P/N 19114-00). [Table 11-1](#) lists the kit parts.

**Table 11-1 Check Tag Kit Parts List**

Quantity	Description
1	Terminal connector strip (9 position)
2	Self-tapping screw
1	Plastic connector housing sleeve
2	Plastic nut cap with rubber insert
1	Nylon closing cap
1	Check Tag Assembly Instructions

You need the following additional materials and/or tools to complete the installation.

- AT5270 Check Tag(s)
- Jeweler flat-blade screwdriver
- Standard tools (Phillips screwdriver, wire stripper, crescent wrench)
- Multiprotocol Rail Reader

## Procedures

---

### To assemble the kit for two check tags

1. Strip the cable insulation to expose the three check tag wires. Strip wire insulation approximately 1/4 inches to expose bare wire. Slide the plastic nut and rubber grommet over the wires ([Figure 11-1](#)).

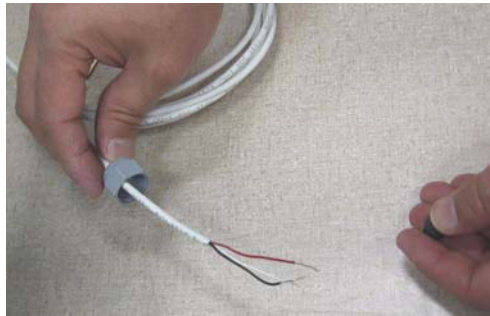

**Figure 11-1 Place Nut and Grommet Over Exposed Check Tag Wires**

2. Pull the check tag wires through the connector housing (Figure 11-2).



**Figure 11-2 Feed Check Tag Wires through Plastic Housing Connector**

3. For Check Tag 0, insert and tighten the check tag wires to the terminal strip as shown in Figure 11-3 and Table 11-2.

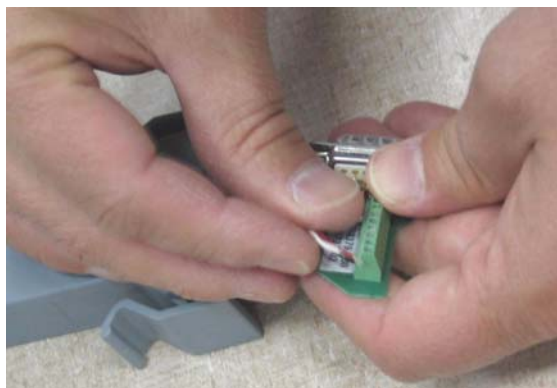

**Figure 11-3 Connect Check Tag Wires**

**Table 11-2 Check Tag 0 Wire Assignments**

Wire	Color	Pin No.
Ground	Black	3
Power	Red	4
Data	White	5



4. If connecting two check tags, repeat steps 1 through 3. Connect Check Tag 1 to the terminal strip as listed in [Table 11-3](#).

**Table 11-3 Check Tag 1 Wire Assignments**

Wire	Color	Pin No.
Ground	Black	7
Power	Red	8
Data	White	9

[Figure 11-4](#) shows both check tags connected to terminal strip.



**Figure 11-4 Two Check Tag Assemblies Connected to Terminal Strip**

5. Insert and tighten the two self-tapping screws to secure the terminal strip ([Figure 11-5](#)).



**Figure 11-5 Securing Terminal Strip into Connector Housing**

6. To complete the connector assembly, tighten the nuts on the cable end snugly (Figure 11-6).

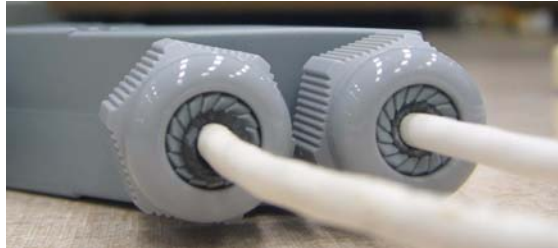

**Figure 11-6 Plastic Nuts with Grommets**

As the nut is tightened, the connector compresses the grommet around the check tag cable.

**To assemble the kit for one check tag**

1. Follow the procedure steps described above in steps 1 through 6, but connect only one check tag cable.



**Caution**

*If connecting only one check tag, you must insert and secure the nylon closing cap into the unused terminal connector to protect the terminal strip from possible contamination.*

2. To cover the unused terminal connector, insert the nylon closing cap into the plastic cap with rubber grommet and tighten snugly (Figure 11-7).



**Figure 11-7 Nylon Cap Securely Fastened in Unused Port**

**To connect the check tag assembly to the MPRR**

Remove the dust cover from the Check Tag port of the MPRR and plug in the check tag cable assembly (Figure 11-8). Be sure that the two handles snap into place on the MPRR. This ensures a solid connection.



**Figure 11-8 Check Tag Assembly Secured to MPRR Port (single check tag assembly shown)**



A

---

Glossary



# Appendix A

---

## Glossary

### A

<b>AAR</b>	Association of American Railroads
<b>AC</b>	alternating current
<b>ACK</b>	acknowledge (data valid)
<b>ANSI</b>	American National Standards Institute
<b>antenna</b>	passive device that converts RF energy into magnetic energy (RF signal)
<b>ASCII</b>	American Standard Code for Information Interchange
<b>ASIC</b>	application-specific integrated circuit
<b>ATA</b>	American Trucking Association
<b>aux</b>	auxiliary
<b>AWG</b>	AWG (American Wire Gauge) is a U.S. standard set of non-ferrous wire conductor sizes

### B

<b>backscatter</b>	portion of an RF signal that is modulated by a tag and radiated back to the reader
<b>baud</b>	measure of number of bits per second of a digital signal; for example, 9600 baud = 9600 bits per second
<b>BCKS</b>	boot checksum
<b>BCM</b>	buffer control mode
<b>bps</b>	bits per second
<b>byte</b>	a binary character; for example, one 8-bit ASCII character

### C

<b>check tag</b>	tag mounted inside a reader assembly, inside or in close proximity to an external antenna that is used to check operation of the reader
------------------	---

## ***Multiprotocol Rail Reader System Guide***

<b>cmd</b>	command
<b>comm</b>	communications
<b>command</b>	data set that is recognized by the receiving device as intending to elicit a specific response
<b>conduit</b>	flexible steel pipe use for electrical wiring
<b>cps</b>	characters per second
<b>CR</b>	carriage return
<b>CRC</b>	cyclic redundancy check
<b>CTRL</b>	control
<b>CTS</b>	clear to send

## **D**

<b>data</b>	information that is processed by a computing device
<b>DC</b>	direct current
<b>DIAG</b>	diagnostic

## **E**

<b>ECP</b>	error correcting protocol
<b>ECPS</b>	error correcting protocol status
<b>eGo<sup>®</sup></b>	Proprietary name for ANSI NCITS 256-2001 and ISO 18000-6B compliant TransCore products. A registered trademark of TC License, Ltd.
<b>eol</b>	end of line
<b>eom</b>	end of message
<b>EPROM</b>	erasable programmable read-only memory

## **F**

<b>field</b>	physical area/space in which a tag can be read by the reader; also, an element of a data record/frame. For example, division within a tag's data frame.
--------------	---



**frames** consecutive bits of data in memory that are read and written as a group  
**frequency bands** a range of RF frequencies assigned for transmission by an RF device

**H**

**hex** hexadecimal  
**hexadecimal** base 16 numbering system that uses the characters 0 through 9 and A through F to represent the digits 0 through 16  
**host** device, generally a computer, that is connected to the Multiprotocol Rail Reader through the communications port

**I**

**I/O or IO circuits** input/output circuits  
**ID** identification; encoded information unique to a particular tag  
**NCITS** American National Standards Institute International Committee for Information Technology standards  
**interface** connection point for communication with another device  
**IOST** I/O status  
**ISO** International Standardization Organization

**L**

**LF** line feed

**M**

**m** meter  
**MHz** megahertz  
**mode** method of operation  
**MPPRR** Multiprotocol Rail Reader  
**ms** millisecond(s)

**N**

**NAK** negative acknowledgment (data not valid)

**P**

**passback** used to refer to a tag ID that is not passed on to the tag buffer

**PC** personal computer

**PCKS** EPROM flash checksum

**protocol** specified convention for the format of data messages communicated between devices

**PRST** presence status

**PWRB** power fail bit

**R**

**RAM** random access memory

**RDID** reader ID

**read** process of acquiring data from a device; for example, from a tag or from computer memory

**reader** controlled interrogating device capable of acquiring data from a device; for example, acquiring and interrupting data from a tag

**read zone** the physical area in which a tag can be read by the reader

**RF** radio frequency

**RFID** radio frequency identification

**RFST** RF status

**ROM** read-only memory

**RTC** real-time clock

**RTS** request-to-send

**S**

**SCTS** status of check tag status

<b>SeGo</b>	Super eGo (SeGo) is a superset of the eGo protocol
<b>SN</b>	serial number
<b>som</b>	start of message
<b>SSTC</b>	input status change reporting options
<b>T</b>	
<b>tag</b>	small self-contained device acting as an identifying transponder
<b>TRU™</b>	Train Recording Unit
<b>TT</b>	tag translation
<b>V</b>	
<b>v</b>	volts
<b>Ver</b>	version (software)
<b>W</b>	
<b>write</b>	process of recording data; for example, writing to computer memory or to a tag's memory. Writing writes over (erases) previous data stored at the specified memory locations.
<b>X</b>	
<b>XON/XOFF</b>	protocol for controlling the flow of data between computers and other devices on an asynchronous serial connection. X/ON and X/OFF are signals to turn a transmitter on or off. The actual signal for X/ON is the same bit configuration as the ASCII Ctrl-Q keyboard combination (11 hexadecimal). The X/OFF signal is the Ctrl-S character (13 hexadecimal).



# B

---

## Technical Specifications



# Technical Specifications

## Reader Specifications

### Communications

<b>Frequency Selection</b>	860 to 930 MHz capable <sup>a</sup>
<b>Reading Range</b>	Read performance varies depending on tag, reader, and external antenna configuration and environment. Typical read range should be 12 to 17 ft (3.7 to 5.2 m). <sup>b</sup>

- a. In the U.S., the authorized continuous wave frequency band is 902.25 to 903.75 MHz and 910.00 to 921.50 MHz and the authorized modulated frequency band for this product is 911.75 to 919.75 MHz.
- b. Reading range depends on reader or external antenna configuration, tag type, tag read mode, and operating environment.

### Hardware Features

<b>Integrated system with connectors for external antennas</b>	RF module, tag decoder, power supply, I/O ports, and serial communications interface all housed in a single package.
<b>Case</b>	Anodized aluminum

### Power Requirements

<b>Input Voltage</b>	16 to 20V AC, 47 to 63 Hz or 16 to 28V DC
----------------------	---

### Physical Attributes

<b>Size</b>	13 x 5 x 2.49 in. (33 x 7.62 x 6.32 cm)
<b>Weight</b>	5.1 lb (2.31 kg)

***Environmental Parameters***

<b>Operating Temperature</b>	-40°F to +158°F (-40°C to +70°C)
<b>Humidity</b>	95% condensing
<b>Vibration Tolerance</b>	The MPRR complies with vibration tolerance limits specified in AREMA C&S Manual, Part 11.5.1, Class C
<b>Operation Shock Tolerance</b>	The MPRR complies with shock tolerance limits specified in AREMA C&S Manual, Part 11.5.1, Class C

***Options***

<b>Communications Interface</b>	RS-232
<b>Cable Accessory Kits</b>	58-7001-001: MPRR-to-TRU™ cable assembly, 6 ft (1.8 m) 58-7001-002: MPRR-to-TRU cable assembly, 20 ft (6.1 m) 58-7001-003: MPRR cable assembly, 6 ft (1.8 m), no TRU 58-7001-004 MPRR cable assembly, 20 ft (6.1 m), no TRU
<b>Transformer</b>	A Class C transformer is available to allow 110V AC to 18V AC conversion. Include the part number 76-1620-005 when ordering. A Class C transformer (part number 76-1620-008) to allow 220V AC to 18V AC conversion is available by special request.



C

---

## Wiring Information



## Wiring Information

*This appendix contains a graphical representation showing the wiring connector pin-outs as well as any wiring signal tables used to test and install the Multiprotocol Rail Reader (MPRR).*

### Communications Interfaces

Table C-1 lists the interfaces available with the MPRR.

**Table C-1 Communications Interfaces and Conductor Requirements**

Interface	Number of Conductors
RS-232	3
RS-232 with RTS and CTS hardware handshake signals	5

Figure C-1 shows the pin assignments for the RS-232 interface signal to the host and DB15 connector.

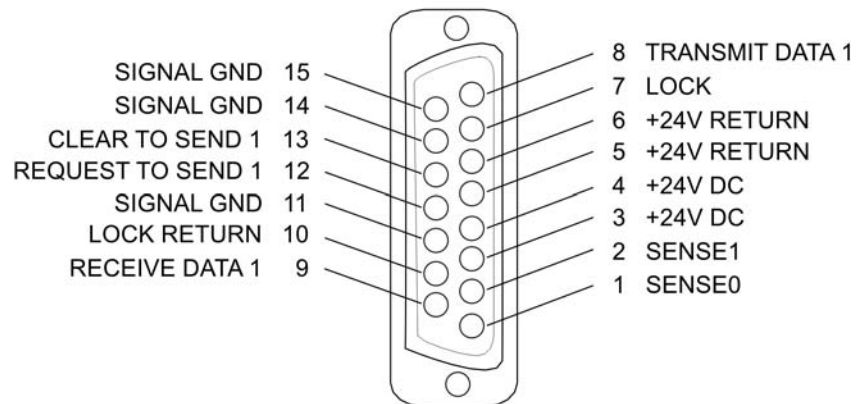

HW-0415

**Figure C-1 DB15 Connector Pin Assignments for Signal to Host**



# D

---

## Command Quick Reference



## Command Quick Reference

*This appendix lists the default configuration settings for the Multiprotocol Rail Reader (MPRR) and its commands. Commands are listed both numerically and alphabetically.*

### Command Syntax

The command numbers consist of from 2 to 4 hex digits. The letters N or S may follow a command number. The letter N indicates that part of the command number is variable. The letter S indicates the requirement for an alphanumeric data string that is to be included immediately following the command number. Hex digits (0–9, A–F) in either uppercase or lowercase characters may be used in data strings and for hex digits A–F. For more information see Chapter 5, “General Software Information” .

Table D-1 lists factory default settings. Table D-2 on page D-5 lists, in numerical order, all of the commands available to users. Table D-3 on page D-15 lists the same commands by command name.

### Factory Default Settings

**Note:** Table D-1 lists the factory default settings for the MPRR.

**Table D-1 MPRR Default Configuration Settings**

Parameter	Setting	Command
Operating mode	Data	00
Baud rate	9600	1005
Stop bits	1	1010
Parity	None	1020
Time and data appended	Enabled	302
Auxiliary information appended	Disabled	310
Unique ID code criteria	Separation of 1 ID	4100
Valid ID code criteria	Acquisition of 1 ID	4200
Uniqueness time-out	2 minutes	441
Tag translation mode	Disabled	452

**Table D-1 MPRR Default Configuration Settings (continued)**

Parameter	Setting	Command
Multi-tag sort	Disabled	454
SeGo protocol tag initialization during multi-tag sort	Enabled	456
Reader ID number	00	6000
Communications protocol	Basic	610
Error correcting protocol (ECP) timeout	12.7 sec	612FE
Flow control	Software (XON/XOFF)	6141
Echo mode	Enabled	6171
RF-by-input control	Enabled	641
ATA operating range (distance)	Maximum	6431F
RF attenuation	Full power	64400
SeGo protocol operating range (distance)	Maximum	6451F
Presence without tag reports	Disabled	6900
RF-off control	Timeout or no presence	6922
RF timeout	Never true	693F
Input inversion	Disabled	6940
Serial number	SSSSSS	695
Store hardware configuration	Hardware configuration not known	696
Automatic periodic RF status report	Disabled	830

## **Numerical Command List**

---

The following conventions are used in [Table D-2](#):

- Items in ***bold italics*** identify factory default settings.
- Only the command-related data portion of the reader message is shown.

Refer to [Chapter 6, “Communications Protocols”](#) for the complete syntax of commands and messages.



**Table D-2 MPRR Commands Listed Numerically**

Number	Command Name	Reader Message
<b>00</b>	<b>Switch to data mode</b>	<b>Done</b>
01	Switch to command mode	Done
1002	Set baud rate = 1200 baud	Done
1003	Set baud rate = 2400 baud	Done
1004	Set baud rate = 4800 baud	Done
<b>1005</b>	<b>Set baud rate = 9600 baud</b>	<b>Done</b>
1006	Set baud rate = 19.2 K baud	Done
1007	Set baud rate = 38.4 K baud	Done
<b>1010</b>	<b>Use one stop bit</b>	<b>Done</b>
1011	Use two stop bits	Done
<b>1020</b>	<b>Disable parity</b>	<b>Done</b>
1021	Select even parity	Done
1022	Select odd parity	Done
20	Set time	Done
21	Set date	Done
22	Display time and date	Time and date
300	No time and date appended	Done
<b>302</b>	<b>Time and date appended</b>	<b>Done</b>
<b>310</b>	<b>Disable aux info append</b>	<b>Done</b>
311	Enable aux info append	Done
40	Transmit all IDs	Done
<b>4100</b>	<b>Select one ID separation</b>	<b>Done</b>
4101	Select two ID separation	Done
4102	Select three ID separation	Done
4103	Select four ID separation	Done
<b>4200</b>	<b>Select 1 valid ID code</b>	<b>Done</b>
4201	Select 2 valid ID codes	Done

**Table D-2 MPRR Commands Listed Numerically (continued)**

Number	Command Name	Reader Message
4202	Select 3 valid ID codes	Done
4203	Select 4 valid ID codes	Done
440	Reset uniqueness	Done
<b>441</b>	<b><i>Set uniqueness time-out to 2 minutes</i></b>	<b>Done</b>
442	Set uniqueness time-out to 15 seconds	Done
443	Set uniqueness time-out to 30 seconds	Done
<b>452</b>	<b><i>Disable tag translation mode</i></b>	<b>Done</b>
453	Enable tag translation mode	Done
<b>454</b>	<b><i>Disable multi-tag sort</i></b>	<b>Done</b>
455	Enable multi-tag sort	Done
<b>456</b>	<b><i>Enable SeGo protocol tag initialization during multi-tag sort</i></b>	<b>Done</b>
457	Disable SeGo protocol tag initialization during multi-tag sort	Done
480	Disable ATA	Done if MPRR model supports this tag protocol. Error if tag protocol is unsupported.
481	Enable ATA	Done if MPRR model supports this tag protocol. Error if tag protocol is unsupported.
484	Disable SeGo	Done if MPRR model supports this tag protocol. Error if tag protocol is unsupported.
485	Enable SeGo	Done if MPRR model supports this tag protocol. Error if tag protocol is unsupported.
488	Disable eATA	Done if MPRR model supports this tag protocol. Error if tag protocol is unsupported.
489	Enable eATA	Done if MPRR model supports this tag protocol. Error if tag protocol is unsupported.

Table D-2 MPRR Commands Listed Numerically (continued)

Number	Command Name	Reader Message
505	Display version	Model [model] Ver [version no.] SN [serial no.]
506	Display hardware configuration information	S...S S...S = ASCII string (maximum length of 20 characters)
520	Display power fail bit	PWRB Px R0 P0 = no power fail has occurred P1 = power fail has occurred R0 = not applicable to the MPRR
521	Display reader ID number	RDID xx xx = 00–FF
522	Display comm port parameters	MAIN Bx Sx Px D0 B2 = 1200 B3 = 2400 B4 = 4800 B5 = 9600 B6 = 19.2 B7 = 38.4 S0 = one stop bit S1 = two stop bits P0 = no parity P1 = even P2 = odd D0 = EOL delay of 0 ms
524	Display appended info status	IDAP T0 D0 Xx T0 = time not appended T1 = time appended D0 = date not appended D1 = date appended X0 = <i>aux info not appended</i> X1 = aux info appended
525	Display comm protocol	ECPS Px Txx Xx S0 P0 = basic P1 = ECP P2 = data Inquiry Txx = ECP timeout ms = 50 * xx FF = disabled ECP timeout X0 = no flow control X1 = software flow control X2 = hardware flow control S0 = som character is #

Table D-2 MPRR Commands Listed Numerically (continued)

Number	Command Name	Reader Message
527	Display RF status	RFST Cx Ox Tx Fxxx Rxx Gxx Axx I04 C0 = RF controlled by host C1 = RF-by-presence sensor O0 = RF off O1 = RF on T1 = uniqueness timeout of 2 min T2 = uniqueness timeout of 15 sec T3 = uniqueness timeout of 30 sec Fxxx = RF output frequency, xxx = 000 to 118 Rxx = Tag decoder range (distance) for ATA tags, 00 to 1F hexadecimal range value Gxx = Tag decoder range (distance) for eGo Plus Tags, 00 to 1F hexadecimal range value Axx = RF power attenuation, 00 max to 0A min (10 dB less than max) I04 = fixed <b>Note</b> If you enter RF settings using command #642NN, the display command for RF output frequency, F is "Fxx" and indicates use of the backward-compatible frequency entry method.

Table D-2 MPRR Commands Listed Numerically (continued)

Number	Command Name	Reader Message
529	Display presence input status	PRST Px D0 Ax Tx Ix P0 = disable presence w/o tag reports P1 = enable presence w/o tag reports D0 = min presence true period of 0 ms A0 = RF off on timeout A1 = RF off on timeout or tag A2 = RF off on timeout or no presence T0: RF timeout of 0 ms (always expired)  T1: RF timeout of 4 ms T2: RF timeout of 8 ms T3: RF timeout of 12 ms T4: RF timeout of 20 ms T5: RF timeout of 24 ms T6: RF timeout of 32 ms T7: RF timeout of 48 ms T8: RF timeout of 60 ms T9: RF timeout of 92 ms TA: RF timeout of 152 ms TB: RF timeout of 300 ms TC: RF timeout of 452 ms TD: RF timeout of 600 ms TE: RF timeout of 752 ms TF: RF timeout infinite, never expires (factory default) I0 = Input inversion disabled (factory default) I1 = Input inversion enabled
530	Display RF0 filter status	RF0S Ux V0 U0 = one ID separation (factory default) U1 = two ID separation U2 = transmit all IDs U3 = buffer all IDs V0 = valid ID code criteria of one acquisition (factory default) V1 = valid ID code criteria of two acquisitions V2 = valid ID code criteria of three acquisitions V3 = valid ID code criteria of four acquisitions
534	Display tag translation mode status	TT <0 to 1> 0 = tag translation mode disabled 1 = tag translation mode enabled

Table D-2 MPRR Commands Listed Numerically (continued)

Number	Command Name	Reader Message
537	Display echo status	ECHO x 0 = disabled (factory default) 1 = enabled
540	Display flash checksum	PCKS I0000 Exxxx xxxx = 4-byte ASCII checksum
543	Display boot checksum	BCKS xxxx xxxx = 4-byte ASCII checksum
549	Get user-programmable group select equals (GSE) filter data	The response data is formatted similar to the data in the configuration command.
552	Request sensor status change	Reader response: MUX x<0 to 3> <MPRR> where x = 0 antenna multiplexing disabled, RF on port 0 only x = 1 antenna multiplexing between RF ports 0 and 1 when sense0 active x = 2 antenna multiplexing between RF ports 0 and 1 when sense0 active and RF port 2 when sense1 active x = 3 antenna multiplexing between RF ports 0 and 1 when sense0 active and RF ports 2 and 3 when sense1 active MPRR = MPRR mode selected
560	Display input status change	SSTC Ex Mx E0 = status change reports disabled E1 = status change reports enabled M0 = no reporting M1 = report change on input0 M2 = report change on input1 M3 = report change on either input
570	Display operating mode status	ATA:<E, D> eGo:<I, F, D> SeGo:<I, F, D> IAG:<E, D> Sort:<E, D> I = ID (64 bits) E = Enabled F = Full transaction (eATA) D = Disabled

Table D-2 MPRR Commands Listed Numerically (continued)

Number	Command Name	Reader Message
577	Report buffered handshakes	XX = number of handshakes
60NN	Set reader ID number NN = 00–FF (00 = factory default)	Done
<b>610</b>	<b>Select basic protocol</b>	<b>Done</b>
611	Select ECP protocol	Done
612NN	Set ECP timeout NN = 01–FE (1–255) timeout = 50 ms * NN (if NN = FF, timeout is disabled)	Done
<b>612FE</b>	<b>Set ECP timeout = 12.7 sec</b>	<b>Done</b>
613	Enable data inquiry protocol	Done
6140	Disable flow control	Done
<b>6141</b>	<b>Enable software flow control</b>	<b>Done</b>
6142	Enable hardware flow control	Done
6170	Disable echo	Done
<b>6171</b>	<b>Enable echo</b>	<b>Done</b>
63	Reset reader	Model [model] Ver [version no.] SN [serial no.] Copyright [date] TransCore
6400	Turn off RF	Done
6401	Turn on RF	Done
<b>641</b>	<b>Select RF-by-input control</b>	<b>Done</b>
642NN	Select RF operating frequency	Done
643NN	Set ATA operating range (distance) NN = 00 (shortest) to 1F (longest) <b>1F = default</b>	Done
644NN	Set RF attenuation NN = 00 to 0A	Done
645NN	Set SeGo protocol operating range (distance) NN = 00 (shortest) to 1F (longest)	Done

Table D-2 MPRR Commands Listed Numerically (continued)

Number	Command Name	Reader Message
647XXX	Select RF operating frequency from 860 to 930 in 250 kHz steps XXX = 000 - 118 (hexadecimal)	Done
65	Reset power fail bit	Done
66F	Load default operating parameters (except RF operating frequency)	Done
<b>6900</b>	<b>Disable presence without tag reports</b>	<b>Done</b>
6901	Enable presence without tag reports	Done
6920	Turn RF off on timeout	Done
6921	Turn RF off on timeout/tag	Done
<b>6922</b>	<b>Turn RF off on timeout/no presence</b>	<b>Done</b>
693N	Set RF timeout N = 0–F (always expired, 4,8,12,20,24, 32,48,60,92,152, 300,452, 600,752, infinite)	Done
<b>693F</b>	<b>Set RF timeout = infinite</b>	<b>Done</b>
<b>6940</b>	<b>Disable input inversion</b>	<b>Done</b>
6941	Enable input inversion	Done
<b>695S...S</b>	<b>Set serial number S...S = ASCII string (maximum length of 6 characters)</b>	<b>Done</b>
<b>696S...S</b>	<b>Store hardware configuration string S...S = ASCII string (maximum length of 20 characters)</b>	<b>Done</b>



**Table D-2 MPRR Commands Listed Numerically (continued)**

Number	Command Name	Reader Message
697	Set user-programmable group select equals (GSE) filter 697 MM AA DDDDDDDDDDDDDDDDD where MM = determines which of the eight comparison data bytes are to be compared for the Group Select filter AA = determines the start address in the tag memory for the comparison data D...D = 8-byte field (16 characters) used by the tag as the comparison data for the group select filter	Done
8110	Switch on RF port 0, fire off check tag address 0 on check tag pin 0	Done
8111	Switch on RF port 1, fire off check tag address 1 on check tag pin 0	Done
8112	Switch on RF port 2, fire off check tag address 0 on check tag pin 1	Done
8113	Switch on RF port 3, fire off check tag address 1 on check tag pin 1	Done
8142X	Set check tag character on check tag pin 0	Done
8143X	Set check tag character on check tag pin 1	Done
8150	Set check tag address to 0 on check tag pin 0	Done
8151	Set check tag address to 1 on check tag pin 0	Done
8152	Set check tag address to 0 on check tag pin 1	Done
8153	Set check tag address to 1 on check tag pin 1	Done

**Table D-2 MPRR Commands Listed Numerically (continued)**

<b>Number</b>	<b>Command Name</b>	<b>Reader Message</b>
<b>830</b>	<b><i>Disable automatic periodic RF status report</i></b>	<b><i>Done</i></b>
831	Enable automatic periodic RF status report	Done
836	Disable MPRR mode	Done
837	Enable MPRR mode	Done
<b>850</b>	<b><i>MUX RF port 0</i></b>	<b><i>Done</i></b>
851	MUX between RF ports 0 and 1	Done
852	MUX between RF ports 0, 1, and 2	Done
853	MUX between RF ports 0, 1, 2, and 3	Done
891	MUX test mode RF port 1 only	Done
892	MUX test mode RF port 2 only	Done
893	MUX test mode RF port 3 only	Done

## Alphabetical Command List

---

The following conventions are used in [Table D-3](#):

- Items in *bold italics* identify factory default settings.
- Only the command-related data portion of the reader message is shown.

Refer to [Chapter 7, “Commands”](#) for the complete syntax of commands and messages.

**Table D-3 MPRR Commands Listed Alphabetically**

Command Name	Code	Reader Message
All IDs transmit	40	Done
Appended info status display	524	IDAP T0 D0 Xx T0 = time not appended T1 = time appended D0 = date not appended D1 = date appended X0 = aux info not appended X1 = aux info appended
ATA disable	480	Done if MPRR model supports this tag protocol. Error if tag protocol is unsupported.
ATA enable	481	Done if MPRR model supports this tag protocol. Error if tag protocol is unsupported.
ATA operating range set NN = 00 (shortest) to 1F (longest) <b>1F = default</b>	643NN	Done
<b><i>Automatic periodic RF status report disable</i></b>	<b>830</b>	<b>Done</b>
Automatic periodic RF status report enable	831	Done
<b><i>Aux info append disable</i></b>	<b>310</b>	<b>Done</b>
Aux info append enable	311	Done
<b><i>Basic protocol select</i></b>	<b>610</b>	<b>Done</b>
Baud rate = 1200 baud set	1002	Done
Baud rate = 19.2 K baud set	1006	Done
Baud rate = 2400 baud set	1003	Done
Baud rate = 38.4 K baud set	1007	Done
Baud rate = 4800 baud set	1004	Done

**Table D-3 MPRR Commands Listed Alphabetically (continued)**

Command Name	Code	Reader Message
<b>Baud rate = 9600 baud set</b>	<b>1005</b>	<b>Done</b>
Boot checksum display	543	BCKS xxxx xxxx = 4-byte ASCII checksum
Buffered handshake report	577	XX = number of handshakes
Comm port parameters display	522	MAIN Bx Sx Px D0 B0 = 110 B1 = 300 B2 = 1200 B3 = 2400 B4 = 4800 B5 = 9600 B6 = 19.2 B7 = 38.4 S0 = one stop bit S1 = two stop bits P0 = no parity P1 = even P2 = odd D0 = EOL delay of 0 ms
Comm protocol display	525	ECPS Px Txx Xx S0 P0 = basic P1 = ECP P2 = data inquiry Txx = ECP timeout ms = 50 * xx TFF = disabled ECP timeout X0 = no flow control X1 = software flow control X2 = hardware flow control S0 = SOM character is #
Command mode switch	01	Done
Data inquiry protocol enable	613	Done
<b>Data mode switch</b>	<b>00</b>	<b>Done</b>
Date set	21	Done
Default operating parameters load (except RF operating frequency)	66F	Done
eATA disable	488	Done if MPRR model supports this tag protocol. Error if tag protocol is unsupported.
eATA enable	489	Done if MPRR model supports this tag protocol. Error if tag protocol is unsupported.

Table D-3 MPRR Commands Listed Alphabetically (continued)

Command Name	Code	Reader Message
Echo disable	6170	Done
<b>Echo enable</b>	<b>6171</b>	<b>Done</b>
Echo status display	537	ECHO x 0 = disabled 1 = enabled
ECP protocol select	611	Done
<b>ECP timeout set = 12.7 sec</b>	<b>612FE</b>	<b>Done</b>
ECP timeout set NN = 01–FE (1–255) timeout = 50 ms * NN (if NN = FF, timeout is disabled)	612NN	Done
Even parity select	1021	Done
Flash checksum display	540	PCKS I0000 Exxxx xxxx = 4-byte ASCII checksum
Flow control disable	6140	Done
Get user-programmable group select equals (GSE) filter data	549	The response data is formatted similar to the data in the configuration command.
Hardware configuration information display	506	S...S S...S = ASCII string (maximum length of 20 characters)
<b>Hardware configuration string store</b> <b>S...S = ASCII string</b> <b>(maximum length of 20</b> <b>characters)</b>	<b>696S...S</b>	<b>Done</b>
Hardware flow control enable	6142	Done
<b>Input inversion disable</b>	<b>6940</b>	<b>Done</b>
Input inversion enable	6941	Done
Input status change display	560	SSTC Ex Mx E0 = status change reports disabled E1 = status change reports enabled M0 = no reporting M1 = report change on input0 M2 = report change on input1 M3 = report change on either input

**Table D-3 MPRR Commands Listed Alphabetically (continued)**

Command Name	Code	Reader Message
MPRR mode disable	836	Done
MPRR mode enable	837	Done
<b>Multi-tag sort disable</b>	<b>454</b>	<b>Done</b>
Multi-tag sort enable	455	Done
<b>MUX RF port 0</b>	<b>850</b>	Done
MUX between RF ports 0 and 1	851	Done
MUX between RF ports 0, 1, and 2	852	Done
MUX between RF ports 0, 1, 2, and 3	853	Done
MUX test mode RF port 1 only	891	Done
MUX test mode RF port 2 only	892	Done
MUX test mode RF port 3 only	893	Done
Odd parity select	1022	Done
Operating mode status display	570	ATA:<E, D> eGo:<I, F, D> SeGo:<I, F, D> IAG:<E, D> Sort:<E, D> I = ID (64 bits) E = Enabled F = Full transaction (eATA) D = Disabled
<b>Parity disable</b>	<b>1020</b>	<b>Done</b>
Power fail bit display	520	PWRB Px R0 P0 = no power fail has occurred P1 = power fail has occurred R0 = not applicable
Power fail bit reset	65	Done

Table D-3 MPRR Commands Listed Alphabetically (continued)

Command Name	Code	Reader Message
Presence input status display	529	PRST Px D0 Ax Tx lx P0 = disable presence w/o tag reports P1 = enable presence w/o tag reports D0 = min presence true period of 0 ms A0 = RF off on timeout A1 = RF off on timeout or tag A2 = RF off on timeout or no presence T0: RF timeout of 0 ms (always expired)  T1: RF timeout of 4 ms T2: RF timeout of 8 ms T3: RF timeout of 12 ms T4: RF timeout of 20 ms T5: RF timeout of 24 ms T6: RF timeout of 32 ms T7: RF timeout of 48 ms T8: RF timeout of 60 ms T9: RF timeout of 92 ms TA: RF timeout of 152 ms TB: RF timeout of 300 ms TC: RF timeout of 452 ms TD: RF timeout of 600 ms TE: RF timeout of 752 ms TF: RF timeout infinite, never expires (factory default) I0 = Input inversion disabled (factory default) I1 = Input inversion enabled
<b>Presence without tag reports disable</b>	<b>6900</b>	<b>Done</b>
Presence without tag reports enable	6901	Done
Reader ID number display	521	RDID xx xx = 00–FF
Reader ID number set NN = 00-FF (00 = factory default)	60NN	Done
Reader reset	63	Model [model] Ver [version no.] SN [serial no.] Copyright [date] TransCore
Report changes both	823	Done
RF attenuation set NN = 00 to 0A	644NN	Done

**Table D-3 MPRR Commands Listed Alphabetically (continued)**

Command Name	Code	Reader Message
RF off on timeout	6920	Done
<b><i>RF off on timeout/no presence</i></b>	<b>6922</b>	<b>Done</b>
RF off on timeout/tag	6921	Done
RF turn off	6400	Done
RF turn on	6401	Done
<b><i>RF on by input control</i></b>	<b>641</b>	<b>Done</b>
RF operating frequency from 860 to 930 in 250 kHz steps select XXX = 000 - 118 (hexadecimal)	647XXX	Done
RF operating frequency select	642NN	Done
RF status display	527	<p>RFST Cx Ox Tx Fxxx Rxx Gxx Axx I04                      C0 = RF controlled by host                      C1 = RF-by-presence sensor                      O0 = RF off                      O1 = RF on                      T1 = uniqueness timeout of 2 min                      T2 = uniqueness timeout of 15 sec                      T3 = uniqueness timeout of 30 sec                      Fxxx = RF output frequency, xxx = 000 to 118                      Rxx = Tag decoder range (distance) for ATA tags, 00 to 1F hexadecimal range value                      Gxx = Tag decoder range (distance) for eGo Plus Tags, 00 to 1F hexadecimal range value                      Axx = RF power attenuation, 00 max to 0A min (10 dB less than max)                      I04 = fixed</p> <p>If you enter RF settings using command #642NN, the display command for RF output frequency, F is "Fxx" and indicates use of the backward-compatible frequency entry method.</p>
<b><i>RF timeout = infinite set</i></b>	<b>693F</b>	<b>Done</b>



**Table D-3 MPRR Commands Listed Alphabetically (continued)**

Command Name	Code	Reader Message
RF timeout set N = 0–F (always expired, 4,8,12,20,24,32, 48,60,92,152,300,452,600,752 ms, infinite)	693N	Done
RF0 filter status display	530	RF0S Ux V0 U0 = one ID separation U1 = two ID U2 = transmit all
SeGo disable	484	Done if MPRR model supports this tag protocol. Error if tag protocol is unsupported.
SeGo enable	485	Done if MPRR model supports this tag protocol. Error if tag protocol is unsupported.
SeGo protocol operating range set NN = 00 (shortest) to 1F (longest)	645NN	Done
<b>SeGo protocol tag initialization during multi-tag sort</b>	<b>456</b>	<b>Done</b>
SeGo protocol tag initialization during multi-tag sort disable	457	Done
<b>Serial number set S...S = ASCII string (maximum length of 6 characters)</b>	<b>695S...S</b>	<b>Done</b>
Set check tag character on check tag pin 0	8142X	Done
Set check tag character on check tag pin 1	8143X	Done
Set check tag address to 0 on check tag pin 0	8150	Done
Set check tag address to 1 on check tag pin 0	8151	Done
Set check tag address to 0 on check tag pin 1	8152	Done
Set check tag address to 1 on check tag pin 1	8153	Done

**Table D-3 MPRR Commands Listed Alphabetically (continued)**

Command Name	Code	Reader Message
Set user-programmable group select equals (GSE) filter 697 MM AA DDDDDDDDDDDDDDDDD where MM = determines which of the eight comparison data bytes are to be compared for the Group Select filter AA = determines the start address in the tag memory for the comparison data D...D = 8-byte field (16 characters) used by the tag as the comparison data for the group select filter	697	Done
<b>Software flow control enable</b>	<b>6141</b>	<b>Done</b>
<b>Stop bit use one</b>	<b>1010</b>	<b>Done</b>
Stop bit use two	1011	Done
Switch on RF port 0, fire off check tag address 0 on check tag pin 0	8110	Done
Switch on RF port 1, fire off check tag address 1 on check tag pin 0	8111	Done
Switch on RF port 2, fire off check tag address 0 on check tag pin 1	8112	Done
Switch on RF port 3, fire off check tag address 1 on check tag pin 1	8113	Done
Tag ID separation select four	4103	Done
<b>Tag ID separation select one</b>	<b>4100</b>	<b>Done</b>
Tag ID separation select three	4102	Done
Tag ID separation select two	4101	Done
Tag translation mode status display	534	TT <0 to 1> 0 = tag translation mode disabled 1 = tag translation mode enabled

**Table D-3 MPRR Commands Listed Alphabetically (continued)**

Command Name	Code	Reader Message
<b>Time and date appended</b>	<b>302</b>	<b>Done</b>
Time and date display	22	Time and date
Time and date not appended	300	Done
Time set	20	Done
Uniqueness reset	440	Done
<b>Uniqueness time-out set to 2 minutes</b>	<b>441</b>	<b>Done</b>
Uniqueness time-out set to 15 seconds	442	Done
Uniqueness time-out set to 30 seconds	443	Done
Valid ID code select four	4203	Done
<b>Valid ID code select one</b>	<b>4200</b>	<b>Done</b>
Valid ID code select three	4202	Done
Valid ID code select two	4201	Done
Version display	505	Model [model] Ver [ver no.] SN [serial no.]



E

---

## Compatible Tag Information



## Compatible Tag Information

*This appendix gives helpful information about the tags that are compatible with the Multiprotocol Rail Reader (MPRR).*

### Tag Configurations

Table E-1 lists the TransCore Super eGo<sup>®</sup> (SeGo) protocol tags that are compatible with the MPRR.

**Table E-1 SeGo Protocol Tags**

Tag Model Number	Tag Type	Power Source	Number of 6-bit ASCII Characters <sup>a</sup>	Number of 128-Bit Frames <sup>a</sup>	Special Features
AT5118	Rail	Beam	20	1	915 MHz frequency; high-temperature chemical-resistant case, metal external install
AT5133	Transportation	Beam	20	1	915 MHz frequency; high-temperature chemical-resistant case, metal external install
AT5412	Transportation	Beam	10	1/2	915 MHz frequency; high-temperature chemical-resistant case, metal external install
AT5549	Rail	10-year battery	20	1	915 MHz frequency; water-resistant, metal external install

a. These fields apply to eATA-programmed tags only. Contact TransCore for information regarding tags programmed with these features.

Table E-2 lists most AAR-formatted tag models that are compatible with the MPRR.

**Table E-2 AAR-formatted Tags**

Tag Model Number	Tag Type	Power Source	Number of 6-Bit ASCII Characters	Number of 128-Bit Frames	Special Features
AT5110	Transportation	Beam	20	1	915 MHz frequency, metal external install

**Table E-2 AAR-formatted Tags (continued)**

Tag Model Number	Tag Type	Power Source	Number of 6-Bit ASCII Characters	Number of 128-Bit Frames	Special Features
AT5112	Access control, transportation	Beam	10	1/2	915 MHz frequency, metal external install
AT5114	Access control, transportation	10-yr battery	10	1/2	Multifrequency, metal external install
AT5117	Rail	External	10	1/2	915 MHz frequency; weather resistant, metal external install
AT5119	Rail	External	10	1/2	915 MHz frequency; weather resistant, metal external install
AT5125	Transportation	Beam	20	1	915 MHz frequency; high-temperature chemical-resistant case, metal external install
AT5510	Transportation	10-yr battery	20	1	Multifrequency, metal external install
AT5704	Transportation	External	4608	256	Multifrequency, dynamic tag, metal external install
AT5707	Transportation	8-yr battery	40 <sup>a</sup>	2	915 MHz frequency, dynamic tag, metal external install

a. If desired, in place of 40 six-bit ASCII characters, the AT5707 can support up to 34 seven-bit ASCII characters.

---

## **Tag Data Formats**

Tags are programmed at the TransCore factory with the tag model number, date of manufacture, and data format. Contact TransCore for special order entry procedures for the format that applies to your system. The following four tag data formats can be used:

- 10-character alphanumeric ASCII — Four alphanumeric characters are fixed and can be used to identify either the dealer or the user. The remaining six positions are numeric and should be unique for each tag issued. For example, the entry ACME000001 might be specified as the first tag on the order entry form from ACME Rail Lines.
- 20-character alphanumeric ASCII — Four alphanumeric characters are typically fixed and the remaining 16 positions are numbered sequentially.
- AAR/ISO — For requirements for this format, refer to ISO 10374 and the most recent version of *Association of American Railroads Standard for Automatic Equipment Identification*.



---

# Index



# Index

---

## A

- AA3110 Parapanel 2-7
- AA3140 PCB Log Periodic 2-7
- AAR 3-3
- ACK/NAK response 6-6
- alignment
  - reader and tag 2-5
- antenna
  - mounting 4-12
- antenna interface 2-12
- antenna selection 2-7
- anti-pass back 7-12
- append
  - time and date selection 7-10
- append information commands 7-10–7-11
- appended information
  - status 7-17
- appended tag data 8-12
- ASCII terminals 7-3
- assignments
  - pin 4-8
- Association of American Railroads 3-3
- asynchronous message/command message collision 6-13
- ATA
  - operating range 7-27
- audible circuit tester 4-4
- audience, system guide 1-3
- automatic periodic RF status report 7-36
- auxiliary information 7-10
- auxiliary reader control commands 7-35–7-37

## B

- basic protocol 7-24
- baud rate 7-7
- boot checksum 7-22
- boot failure message 5-6
- buffer
  - tag/message 5-6
- buffered handshakes 7-24
- buzz box
  - See audible circuit tester

## C

- cable
  - power and communications 2-10
- cable length 2-10
- cabling accessory kits 2-10
- check tag operation 7-37

- Check tag-to-MPRR assembly
  - procedures 11-3
  - required supplies 11-3
- check tag-to-MPRR assembly 11-3–11-7
- coaxial cable performance 2-12
- COM 1 properties dialog box 8-6
- command entry conventions 5-3
- Command Group 0
  - See reader mode control commands
- Command Group 1
  - See communication port control commands
- Command Group 2
  - See real-time clock commands
- Command Group 3
  - See append information commands
- Command Group 4
  - See ID filtering commands
- Command Group 5
  - See reader status commands
- Command Group 6
  - See reader control function commands
- Command Group 8
  - See auxiliary reader control commands
- command mode 7-4, 7-7
  - host transmission formats 6-7
  - sample messages 6-9
  - switch to 6-7
- Command quick reference
  - alphabetical command list D-15
  - factory default settings D-3
  - numerical command list D-4
  - syntax D-3
- command response conventions 5-4
- commands, list of 7-5–7-37
- communication protocols 6-3
- communications
  - verifying 8-7
- Communications interfaces C-3
- communications port control commands 7-7–7-8
- communications port parameters 7-16
- communications protocol 8-17
  - status 7-17
- communications protocols
  - basic protocol 6-4
  - basic protocol command response 6-8
  - basic protocol reader transmission 6-5
  - ECP host response 6-5
  - error correcting protocol 6-4
  - error correcting protocol format 6-5

## **Multiprotocol Rail Reader System Guide**

- communications requirements 2-10
  - communications cables
- Compatible tag information
  - configurations E-3
  - data formats E-4
- computer cables 2-13
- configuring
  - appended tag data 8-12
  - communications protocol 8-17
  - ID separation 8-12
  - parameters 8-12–8-18
  - port communication parameters 8-17
  - radio frequency 8-14
  - reports 8-13
  - reset reader 8-13
  - RF transmission 8-14
    - host controlling 8-15
    - presence controlling 8-15
    - presence detector controlling 8-14
  - sense inputs 8-15
  - sense output device 8-16
  - serial port communications 8-16
  - software flow control 8-17
- configuring the MPRR 8-3–8-12
- connecting
  - communications 4-12
    - required materials 4-13
  - Earth Ground 4-8
  - ground stud location 4-8
  - MPRR to the Host 4-13
  - power 4-8
  - power supply 4-12
  - sense input circuits 4-13
  - sense output circuit 4-14
- connecting sense input 4-13
- connecting sense output 4-13
- connection description dialog box 8-5
- conventions
  - typographical 1-5
- CRC
  - See cyclic redundancy check
- CRC calculation 6-14–6-17
- current requirements 2-11
- current, standby operating 2-11
- current, worst case maximum 2-11
- cyclic redundancy check 6-4

**D**

- data inquiry protocol 7-25
- data mode 7-3, 7-5
- date
  - set 7-9
- DB15 connector 4-8
- default operating parameters 7-30
- default parameters 8-3
- disable

- ATA 7-14
- automatic periodic RF status report 7-36
- eATA 7-15
- echo mode 7-26
- MPRR mode 7-36
- SeGo 7-15
- SeGo protocol tag initialization during multi-tag sort 7-14
- tag translation mode 7-14

Discharging voltage

- required equipment 4-5

display

- appended information status 7-17
- boot checksum 7-22
- communications port parameters 7-16
- communications protocol status 7-17
- echo status 7-22
- flash checksum 7-22
- hardware configuration information 7-15
- input status change report options 7-23
- operating mode status 7-23
- power fail bit 7-16
- presence input status 7-19
- reader ID number 7-16
- RF status 7-18
- RF0 filter status 7-21
- software version 7-15

display tag translation mode status 7-21

display time and date 7-9

download mode 7-5

dry contact closure 2-12

## **E**

- echo mode 7-26
- echo status 7-22
- ECP
  - reliability 6-13
  - timeout 6-11
  - See also error correcting protocol
- electrical requirements 2-10
  - current
  - power cables
- enable
  - ATA 7-15
  - automatic periodic RF status report 7-36
  - data inquiry protocol 7-25
  - eATA 7-15
  - echo mode 7-26
  - MPRR mode 7-36
  - MUX RF port 0 7-36
  - MUX RF ports 0 and 1 7-36
  - MUX RF ports 0, 1, 2, and 3 7-37
  - MUX RF ports 0, 1, and 2 7-37
  - MUX test mode RF port 1 7-37
  - MUX test mode RF port 2 7-37
  - MUX test mode RF port 3 7-37
  - SeGo 7-15

- SeGo protocol tag initialization during multi-tag sort 7-14
- tag translation mode 7-14
- Encompass 4 1-3
- end-of-line delay 7-7
- error correcting protocol 7-24
  - See also ECP
- error correcting protocol format
  - reader transmissions 6-5
- error correcting protocol timeout 7-25
- error messages 9-3
- error transaction 6-13

**F**

- failure conditions
  - host addressed 6-13
  - reader addressed 6-12
- failure conditions, host-addressed
  - asynchronous message/command message collision 6-13
  - illegal or wrong sequence number 6-13
  - incorrect CRC 6-13
  - receive timeout 6-13
  - transmission timeout 6-13
- failure conditions, reader addressed
  - asynchronous message/command message collision 6-13
  - illegal command 6-12
  - illegal sequence number 6-12
  - receive timeout 6-13
  - transmission timeout 6-12
  - wrong sequence number 6-12
- FCC internet site 1-6
- FCC license
  - See licensing requirements
- flash checksum 7-22
- flow control option 7-25
- frequency separation 2-8

**H**

- hardware configuration information 7-15
- hardware configuration string 7-33
- Hyper Terminal 4-13
- Hyper Terminal main screen 8-7

**I**

- ID filtering commands 7-11–7-15
- ID separation 8-12
- illegal sequence number 6-13
- incorrect CRC 6-13
- input inversion option 7-32
- input/output circuits 2-12
- input/output module 2-3
- installing reader 4-3–4-14
  - additional testing materials 4-4
  - on wall or flat surface 4-12
  - optional accessories 4-4
  - outer dimensions and mounting hole locations 4-10
  - required materials 4-3
  - wall or flat surface 4-12

**L**

- licensing requirements 1-5
- line of sight 2-6
- load default operating parameters 7-30
- Locomotive mounting guidelines
  - 3-7
  - tag placement 3-9
  - tag placement window location 3-7

**M**

- Manually disabling ECP for maintenance 6-17
- marketing support 9-6
- mixed population tags 2-4
- mounting antenna 4-12
- mounting reader 4-10
- MPRR
  - repair 9-6
- MPRR-to-TRU connection 10-5
- MPRR-to-TRU interface 10-3–10-6
- multiple reader sites 2-8
- Multiprotocol Rail Reader
  - description 2-3
- MUX operational modes 7-38

**O**

- operating mode status 7-23
- operating modes
  - command mode 7-4
  - data mode 7-3
  - download mode 7-5
- organization, system guide 1-3

**P**

- parameters
  - configuring 8-12
  - default operating 8-3
  - operating 5-4
- parity 7-7, 7-8
- periodic RF status report 7-36
- phone number dialog box 8-5
- pin assignments, signal to host 4-8
- pin assignments, signal to TRU 4-8
- polarization 2-5
  - See also alignment
- port configuration parameters 8-17
- power cables 2-10
- power fail bit 7-16, 7-30
- power failure flag 5-5
- power supply 2-3
- presence input status 7-19
- presence without tag report option 7-30
- Procomm Plus 4-13
- program download 5-5
  - considerations 5-5
  - procedures 5-5
- purpose, system guide 1-3

## **Multiprotocol Rail Reader System Guide**

### **R**

- radio frequency 8-14
  - See also RF
- Rail car mounting guidelines
  - tag placement 3-10
  - tag placement window location 3-9
- read zone 2-8, 4-14
  - fine-tuning 8-18
    - adjusting sensitivity range 8-19
    - lowering output power 8-18
    - orienting antenna(s) 8-18
  - marking 4-14
  - sample 4-15
- reader
  - configuring 8-3
  - description 2-3
  - how it works 2-4
  - installing
    - on wall or flat surface
      - required materials 4-12
  - operating modes 7-3
  - specifications B-3
    - communications B-3
    - hardware B-3
    - physical B-3
    - power requirements B-3
- reader control function commands 7-24–7-34
- reader ID number 7-16, 7-24
- reader logic board 2-3
- reader mode control commands 7-5–7-7
- reader status commands 7-15–7-24
- real-time clock commands 7-8–7-9
- receive timeout 6-13
- recommended mounting locations 3-3
- report
  - buffered handshakes 7-24
- reports 8-13
- reset
  - power fail bit 7-30
  - reader 7-26
  - uniqueness 7-13
- reset reader 8-13
- RF
  - attenuation 7-28
  - control 7-27
  - control algorithm 7-31
  - operating frequency 7-29
  - signals
    - existing interference with 2-9
    - reflection, refraction, and diffraction 2-9
  - status 7-18
  - timeout period 7-31
  - See also radio frequency
- RF module 2-3
- RF signal
  - electrical interference 2-9
  - reflection, refraction, and diffraction 2-9

- RF transmission 8-14
  - host control 8-15
  - presence control 8-15
- RF0
  - filter status 7-21
- RF-by-input control 7-27

### **S**

- second successful tag read screen 8-11
- SeGo 1-3, 3-3
- SeGo protocol
  - operating range 7-28
- select
  - ATA operating range 7-27
  - basic protocol 7-24
  - baud rate 7-7
  - error correcting protocol 7-24
  - error correcting protocol timeout 7-25
  - flow control option 7-25
  - input inversion option 7-32
  - parity 7-8
  - presence without tag report option 7-30
  - RF control algorithm 7-31
  - RF operating frequency 7-29
  - RF timeout period 7-31
  - RF-by-input control 7-27
  - stop bits 7-7
  - unique ID code criteria 7-12
  - valid ID code criteria for RF channel0 7-13
- sense inputs 8-15
- sense output device 8-16
- serial number 7-33
- serial port communications 8-16
- set
  - reader ID number 7-24
  - RF attenuation 7-28
  - SeGo protocol operating range 7-28
  - serial number 7-33
  - uniqueness timeout 7-13
- set check tag address to 0 on check tag pin 0 7-35
- set check tag address to 0 on check tag pin 1 7-35
- set check tag address to 1 on check tag pin 0 7-35
- set check tag address to 1 on check tag pin 1 7-35
- set check tag character on check tag pin 0 7-35
- set check tag character on check tag pin 1 7-35
- set date 7-9
- set time 7-8
- shipping carton contents 4-3
- sign-on message 5-6, 8-8
- site plan 2-3
- site plan, developing 2-3–2-12
- site planning overview 2-4
- software commands 7-3
- software flow control 8-17
- software version 7-15
- software-related information 5-3
- startup 5-5

- stop bits 7-7
  - store hardware configuration string 7-33
  - successful tag read screen 8-11
  - Super eGo 1-3, 3-3
  - switch on
    - RF port 0, fire check tag address 0 on check tag pin 0 7-35
    - RF port 1, fire check tag address 1 on check tag pin 0 7-35
    - RF port 2, fire check tag address 0 on check tag pin 1 7-35
    - RF port 3, fire check tag address 1 on check tag pin 1 7-35
  - switch to
    - command mode 7-7
    - data mode 7-5
  - system description 2-4
  - system guide
    - audience 1-3
    - organization 1-3
    - purpose 1-3
- T**
- tag
    - choosing, installing, and removing 3-3
    - compatible 2-4
    - compatible types 3-3
    - installing
      - recommended mounting locations
        - mounting surface 3-4
        - required materials 3-3
        - surface installation techniques 3-6
        - tag positioning 3-4
    - models 3-3
    - reading mixed population 2-4
    - types 3-3
  - tag decoder 2-3
  - tag read capability
    - verifying 8-9
  - tag translation mode
    - status 7-21
  - Tank car mounting guidelines
    - tag placement 3-12
    - tag placement window location 3-11
  - Technical Support 1-6
  - technical support 1-6, 9-6
  - terminal emulation software
    - starting 8-4
    - using to configure parameters 8-4
  - testing
    - pre-installation 4-4
      - Discharging voltage from external antenna 4-5
      - using audible circuit tester 4-4
  - time
    - set 7-8
  - time and date
    - display 7-9
  - timing and synchronization 6-11
  - traffic flow 2-8
  - Train recording unit
    - interface 10-3
    - system overview 10-3
  - transmission formats, 7-10
  - transmission timeout 6-13
  - transmit all ID codes 7-11
  - troubleshooting 9-3, 9-3-9-6
    - remedies 9-4
    - symptoms 9-4
  - typographical conventions 1-5
- V**
- verify
    - communications 8-7
    - tag read capability 8-9
- W**
- Warning
    - minimum safe distance for maintenance personnel, iv
    - wrong sequence number 6-12, 6-13

***Multiprotocol Rail Reader System Guide***