

Technical Bulletin

© 2026 Southern Technologies Corporation (STC). All rights reserved.

Bulletin Number: TB-2020209-RH01 Rev.4

Date Published: 06 05 2026

Summary: This bulletin provides instructions for mounting, aligning and calibrating the Frauscher Zero-Speed Wheel Sensor Assembly for use with the 2600 series SmartScan AEI.

Critical (Affects safe operation of system)

Informational

Distribution List: NA

Acronyms

UTB: Universal Transient Barrier – the brand name from ERICO for the electrical surge protection device

WSC: Frauscher Wheel Signal Converter

The Frauscher Zero-Speed Wheel Detector Assembly is a rail-mounted device that generates precision wheel timing signals for the SmartScan AEI System. The combination of inductive operating principles and the robust design of the RSR110 Dual-Element Sensor guarantees high reliability, even when subjected to extreme mechanical, electromagnetic, climatic, and environmental working conditions.

The standard 2600-020 AEI System configuration uses two Frauscher RSR110 sensors to form a “truck trap.” The RSR110 wheel sensors are mounted on the inside gauge of the rail 9’ 6” apart. For sites with straight pull-through only movements, a single RSR110 configuration can be used. A WSC must be used for each RSR110 to provide the interface circuitry to the AEI Controller.

Installation

Step 1

Mount Frauscher sensors to the rail. See Figure 1 for a typical site layout. See Figure 3 for alignment dimensions and torque specifications.

NOTE: An instructional video is available for the Frauscher Rail Claw SK140 on Frauscher’s YouTube channel. See link below:

<https://www.youtube.com/watch?v=nvBmkeuhp40>



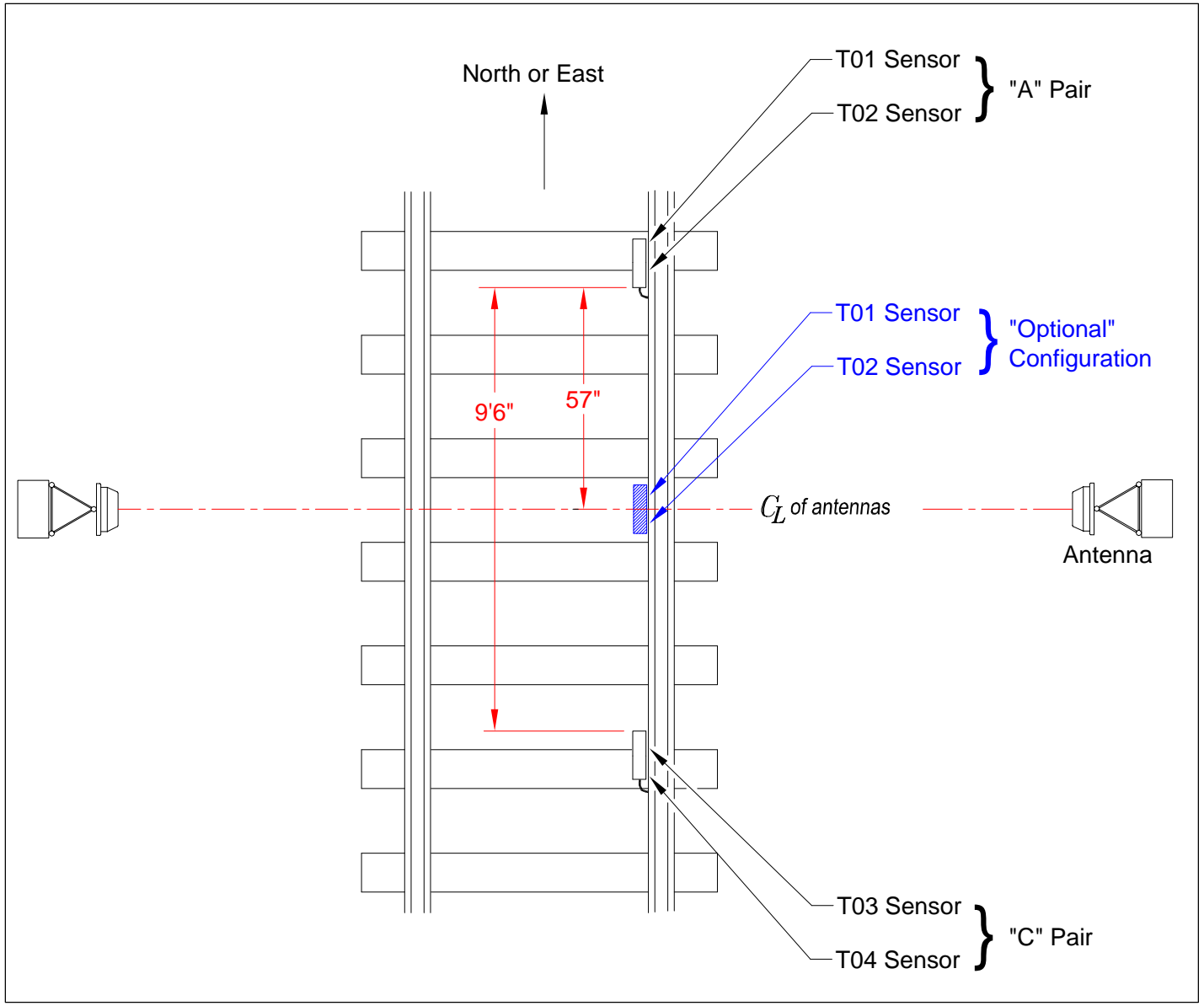

Figure 1: Typical Track Layout

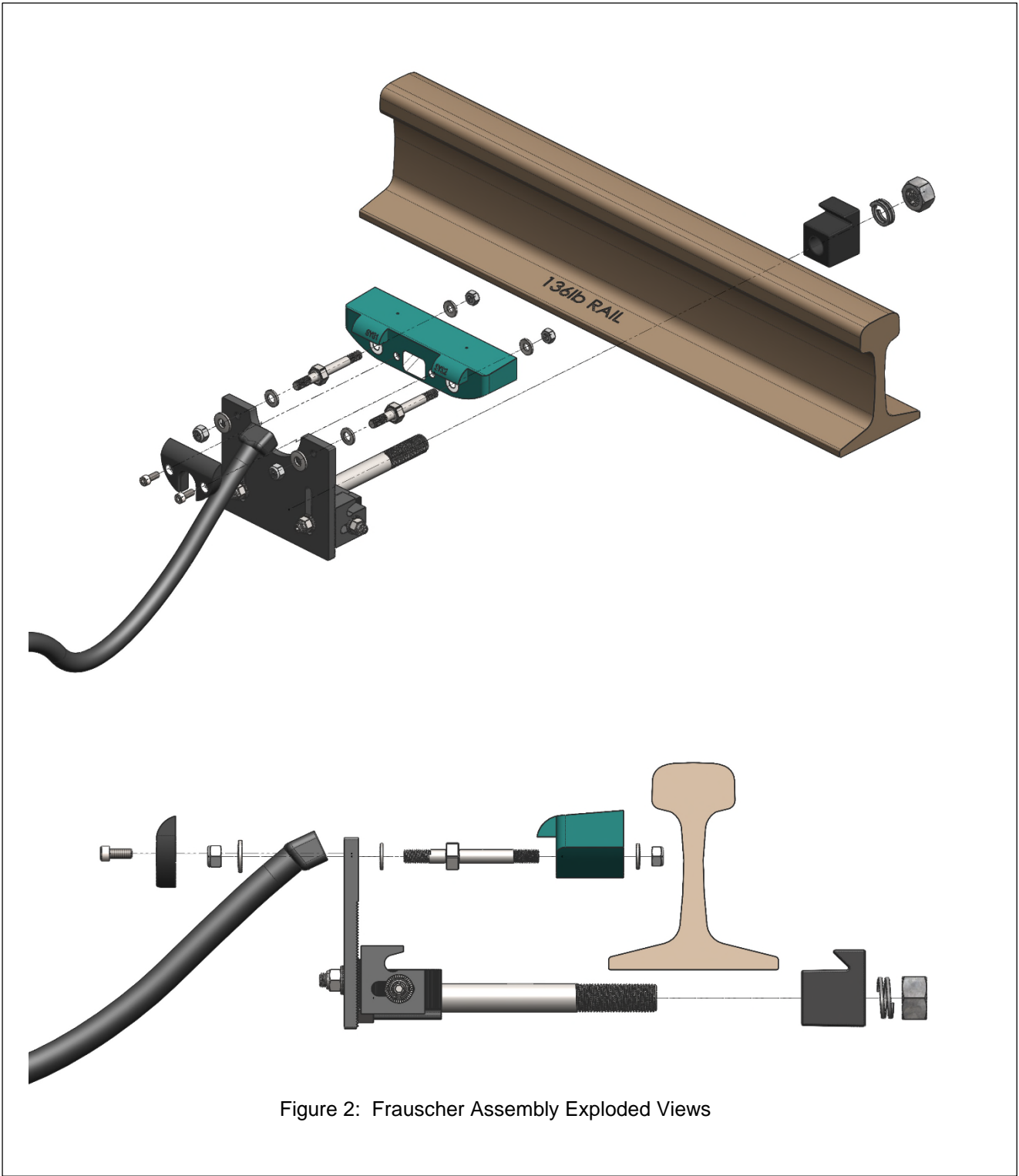

Figure 2: Frauscher Assembly Exploded Views

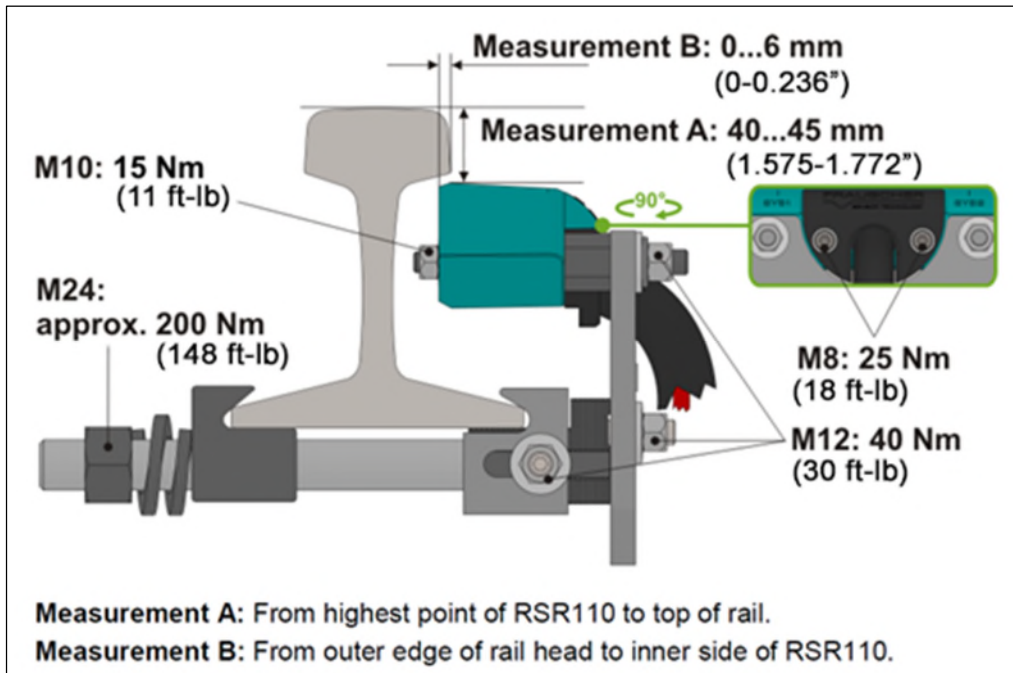

Figure 3: Frauscher Alignment

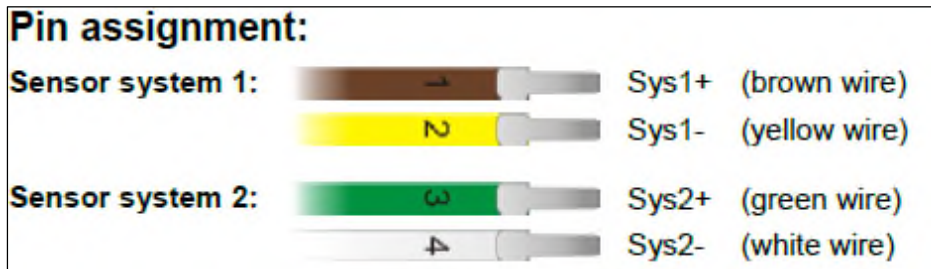

Figure 4: Frauscher Wire Color Code

Step 2

Route the RSR110 sensor cables into the system enclosure. Mount the Frauscher Signal Convert Kit and terminate wiring per Figure 5 (for 2600-547) or Figure 6 for (2600-548).

WIRING FOR 2600-547 FRAUSCHER CONVERTER KIT (SINGLE)

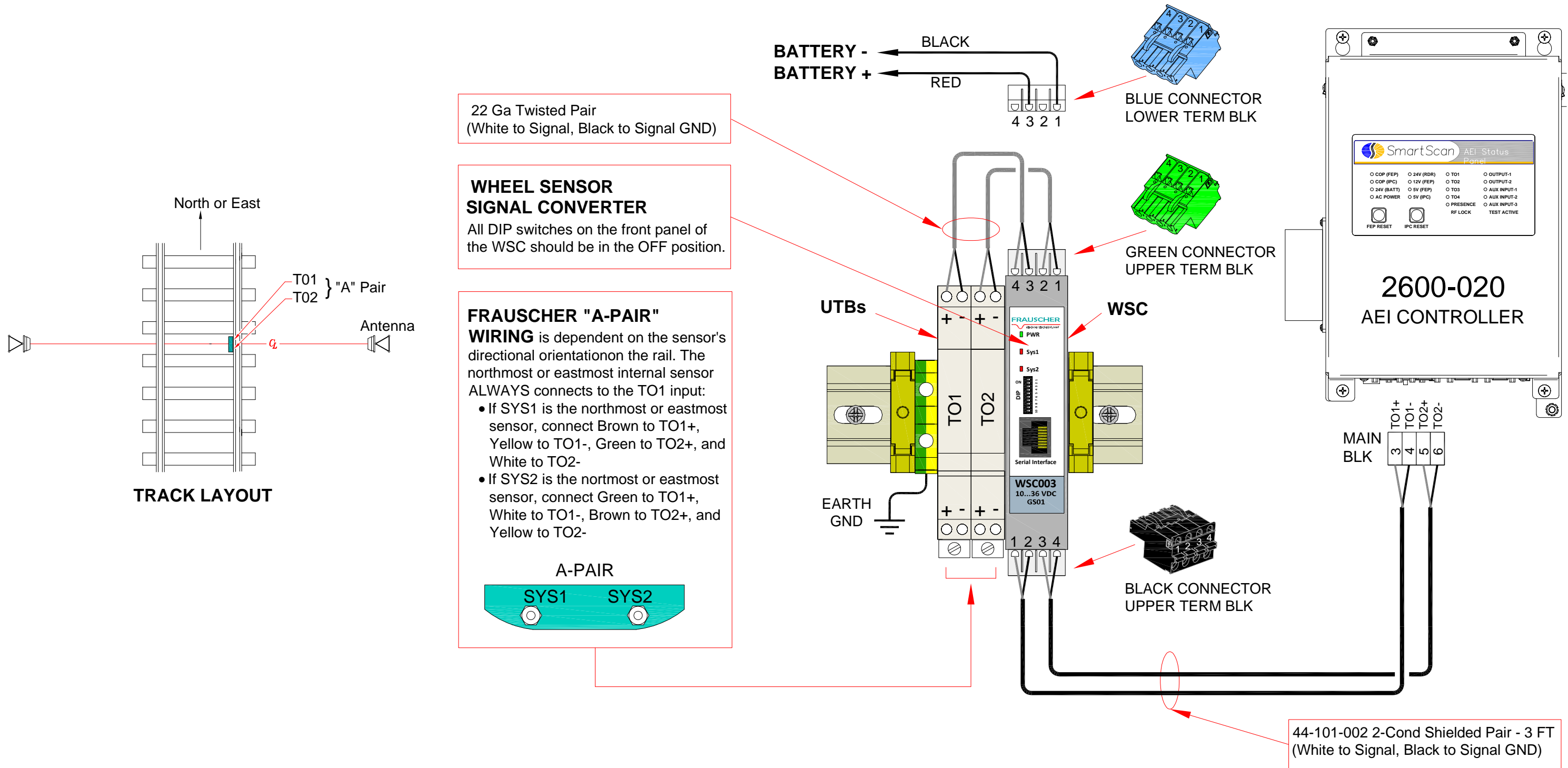

Figure 5: Frauscher Wiring to 2600-020

WIRING FOR 2600-548 FRAUSCHER CONVERTER KIT

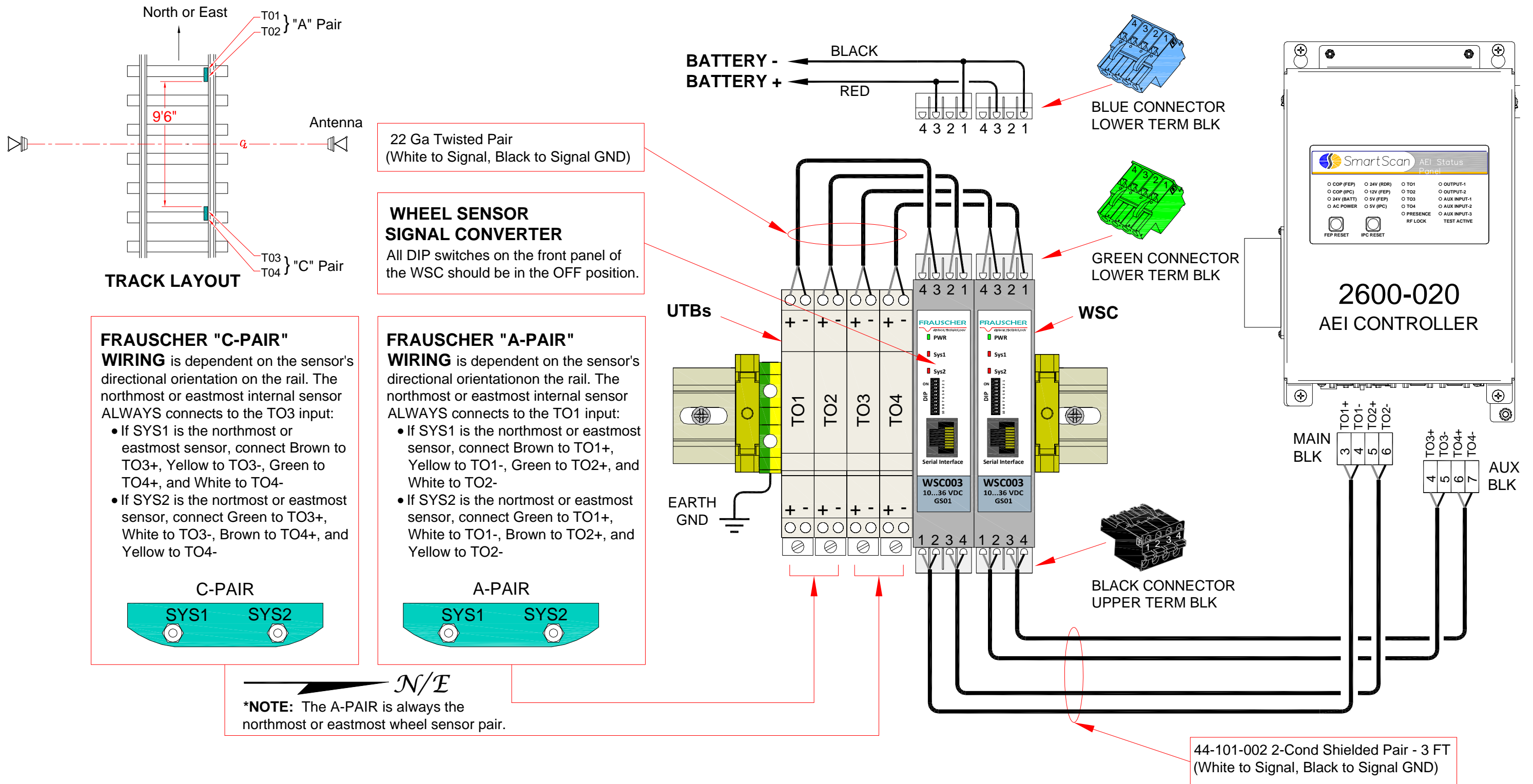

Figure 6: Frauscher Wiring to 2600-020

Step 3

Calibrate sensors. Perform the Automatic Adjustment function for each RSR110 sensor. This function nulls out any influence of the rail and mounting hardware located in the area of the sensor. Run the Automatic Adjustment process after installation and after making any physical changes to sensor alignment. Tie plates, track spikes, rail anchors, rail clips – and similar hardware – used in the area under the sensor do not interfere with the operation. Run the Auto Adjustment function after removing or adding metal hardware in the vicinity of the sensors.

Complete the following steps:

1. Connect sensors to the WSC by following the wiring diagram on the previous page.
2. Apply power to the system.
3. Confirm that the wheel sensors are mounted correctly and are ready for use.
4. To initiate the auto-calibration function, locate the DIP switches on the WSC (see figure below). For **Model WSC001**, move DIP switch number 8 to the ON position for between two and six seconds, then return to the OFF position. For **Model WSC003**, move DIP switch number 10 to the ON position for between two and six seconds, then return to the OFF position.

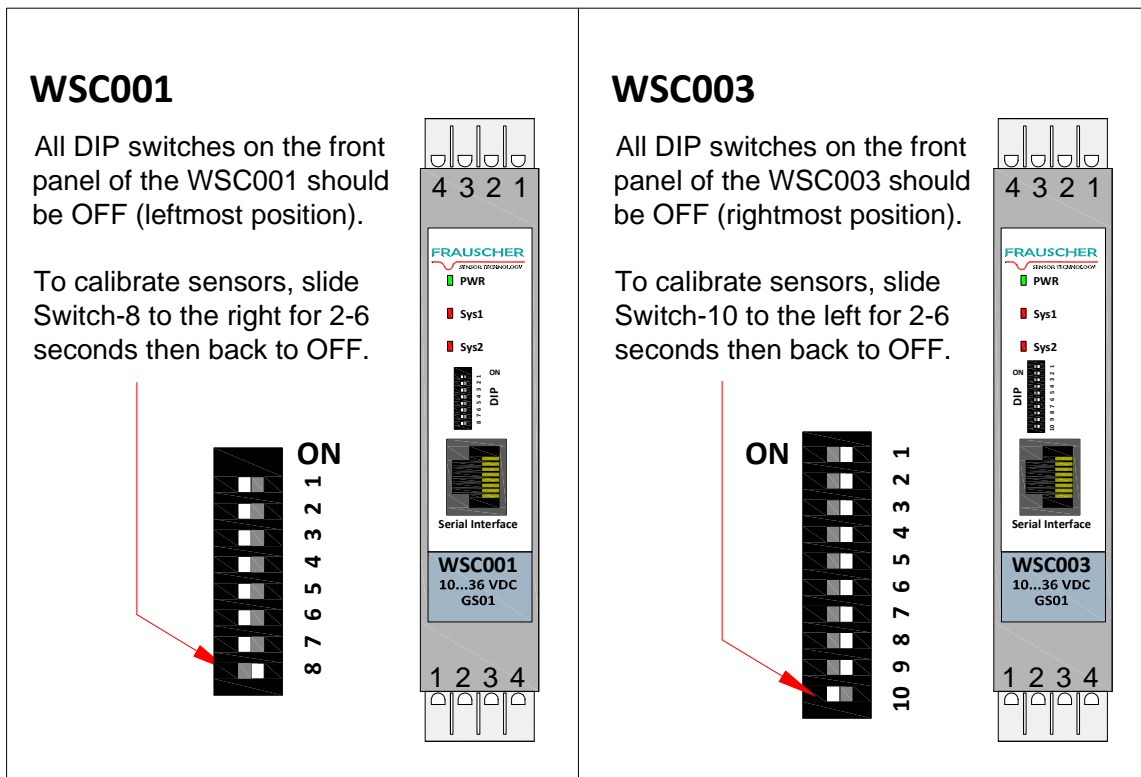

5. As a result, the Sys1 and Sys2 LEDs should light up, indicating that the Automatic Adjustment function has started.
 - The WSC adjusts both wheel sensors simultaneously, requiring up to forty seconds.
 - The Sys1 and Sys2 LEDs turn off when the session finishes, indicating successful calibration.
 - A blinking Sys LED after the calibration process means that the associated sensor(s) did not successfully adjust.

If both wheel sensors indicate Success, calibration is complete.

Step 4

Test occupancy detection. After successful automatic adjustment of both RSR110s, use the PB200 Test Wheel Sensor Target, or a metal object, to test for occupancy.

1. Place the Sensor Target on TO1 (northmost or eastmost sensor). Align the notch on the bottom of the Sensor Target with the hash mark on the top of the RSR110. The TO1 LED on the 2600-020 front panel should light up.
2. Repeat the procedure with sensors TO2-TO4. The respective LEDs on the 2600-020 should light up.



***The Frauscher RSR110 Installation and setup is complete.**

Troubleshooting Guide

I. If the RSR110 sensor fails, check the WSC LED indicators.

WSC PWR LED Off

MEANING	POSSIBLE SOLUTIONS
No power supply	Apply power supply
Wrong polarity	Reverse polarity
Open fuse	Replace WSC

Sys1 / Sys2 LED Flashes Slowly

MEANING	POSSIBLE SOLUTIONS
WSC did not initiate Automatic Adjustment correctly	Run Automatic Adjustment Function
Wire break in the wheel sensor circuit	Check wiring for open circuit
Overcurrent in the wheel sensor circuit	Check wiring for short circuit

II. If the RSR110 sensor fails, check for the correct current flow.

The following information outlines a procedure to measure and verify current flow through a Frauscher wheel sensor. By doing so, you may rule out a possible faulty wheel sensor while troubleshooting a system.

There are approximately five milliamps of current flow through the sensor when it is working correctly, and it is not sensing a target. During this procedure, disconnect the yellow Sys1-sensor wire (or white Sys2- sensor wire) and connect a DC milliamp meter in series with the sensor wiring, thus providing a means to measure current flow through the sensor.

Tools Needed

- A digital Volt/Ohm meter (VOM) with a milliamps setting.
- Small bladed straight slot screwdriver, approximately 1/8 inch wide.

Procedure:

Set the VOM to DC milliamps and connect in series with the yellow sensor wire as follows.

1. Measure the voltage from the brown wire to the battery ground. A voltage reading of from 23 to 24 VDC indicates that the sensor is powered.
2. Set the VOM to measure DC milliamperes as follows. Unplug the red meter lead from the voltage jack on your VOM and plug it into the milliamps jack on the VOM.
3. Disconnect the Sys(X)- sensor wire from any connection between the sensor and the SmartScanNG², and connect the black VOM probe in its place under the terminal.
4. Touch the red meter probe to the loose SYS- sensor wire that you removed from the terminal. You now have the VOM set for milliamps and connected in series with the yellow sensor wire.
5. The meter should measure 5 mA, within a tolerance of +/- 2%.
6. The current measurement should decrease from 5 mA (+/- 2%) as a metal object comes near the sensor. The TO1 or TO2 LED should indicate active as the current measurement drops.

If the current flow is not correct, try the following.

- Run the Automatic Adjustment function.
- Check for breaks in the sensor wiring.
- Rule out the possibility of a faulty surge suppressor.
- Replace the sensor.

III. If the RSR110 sensor will not successfully calibrate:

One possible cause is a reverse polarity condition. Verify that all wiring is properly terminated per Figure 5 or Figure 6. Correct wiring errors as necessary, and run the Automatic Adjustment function again.

Another possible cause is improper alignment. A sensor adjusted too close to the rail can prevent successful calibration. First, verify the accuracy of the horizontal and vertical adjustments as per Figure 3 and adjust as necessary. If the sensor still will not calibrate, try lowering the sensor's vertical height by one notch (0.100 inch) on the sensor bracket. Each adjustment detent in the sensor mounting bracket represents 0.100 inch. Be aware that the bracket may rise while tightening, so recheck your measurement before continuing.

If the sensor does not calibrate successfully after performing all the steps above, consult with a customer service technician at Southern Technologies Corporation 1-423-892-3029.

Preventive Maintenance

Perform the following inspections during scheduled system maintenance:

- Visual and mechanical check.
- Check the wheel sensors for excessive dirt build-up. Clean as necessary.
- Check the wheel sensors for visual damage. Replace as necessary.
- Check the mounting bracket for a secure fit on the rail. Tighten hardware as necessary per required torque settings.
- Check the rubber conduit tube for damage.
- Check cable connection terminals for a secure fit.